

**2311FA Pressure Tester**

**USER INSTRUCTION MANUAL  
BARFIELD M/N 2311FA**

*56-101-00212  
Revision C  
April 12, 2011*

---

BARFIELD, INC.



Corporate Headquarters

4101 Northwest 29th Street

Miami, Florida 33142

[www.barfieldinc.com](http://www.barfieldinc.com)

Email: [gsesales@barfieldinc.com](mailto:gsesales@barfieldinc.com)





## **CONTACT INFORMATION**

Users are requested to notify the manufacturer of any discrepancy, omission, or error found in this manual. Inquiries should include specific questions and reference the publication title, number, chapter, page, figure, paragraph, and effective date.

Please send comments to:

**TECHNICAL CUSTOMER SUPPORT - GSTE  
BARFIELD, INC.  
P.O. BOX 025367  
MIAMI, FL 33102-5367  
USA**

Telephone      **(305) 894-5400**  
                     **(800) 321-1039**

Fax                **(305) 894-5401**

Email             [gsesales@barfieldinc.com](mailto:gsesales@barfieldinc.com)



## **ATTENTION**

Although every effort has been made to provide the end user of this equipment with the most current and accurate information, it may be necessary to revise this manual in the future. Please be sure to complete and return the enclosed **OWNER WARRANTY REGISTRATION CARD** to Barfield in order to validate the warranty and to ensure that you will receive updated information when published. You MUST have your name and address on file at Barfield as a registered user of this equipment, to be able to obtain the service covered by the warranty.

Visit the company website, <http://barfieldinc.com/>, for publication updates.

Please send the Registration Card to:

Barfield, Inc.  
P.O. Box 025367  
Miami, FL 33102-5367  
USA

## REVISION RECORD

REV.	ECO #	REV. DATE	DESCRIPTION OF CHANGE
A	N/A	04/01/99	Initial Release
B	260-00717	01/25/08	Chapters 2 and 3 were reorganized. Updated Fig. 1, 4 and 5, Table of Gauges, and Maintenance Information. Updated Manual Format.
C	260-00829	04/12/11	Updated warranty information.



## **MAINTENANCE AND REPAIR INFORMATION**

The manufacturer of this equipment does not recommend the user to attempt any maintenance or repair. In case of malfunction, contact the manufacturer, to obtain the list of approved repair facilities worldwide, ensuring that this equipment will be serviced using proper procedures and certified instruments.

### BARFIELD PRODUCT SUPPORT DIVISION

Telephone (305) 894-5400  
(800) 321-1039

Fax (305) 894-5401

### Shipping Address:

Barfield, Inc.  
4101 NW 29th Street  
Miami, Florida 33142  
USA

### Mailing Address:

Barfield, Inc.  
P.O. Box 025367  
Miami, FL 33102-5367  
USA

## TABLE OF CONTENTS

Contact Information  
 Attention Page  
 Revision Record  
 Maintenance and Repair Information  
 Table of Contents  
 List of Figures and Tables

CHAPTER	PAGE
<b><u>INTRODUCTION</u></b> .....	1
1. PUBLICATION BREAKDOWN .....	1
2. INFORMATION PROVIDED WITH THE UNIT .....	1
3. RECERTIFICATION .....	3
<b>1 <u>GENERAL INFORMATION</u></b> .....	<b>5</b>
1. PURPOSE OF THE UNIT .....	5
2. DESCRIPTION .....	5
3. RECOMMENDED GAUGES .....	6
4. RECOMMENDED FLUIDS .....	7
5. SHIPPING AND STORAGE .....	7
<b>2. <u>FILLING AND FLUID-CHANGING PROCEDURES</u></b> .....	<b>9</b>
1. FILLING THE TESTER WITH FLUID .....	9
2. CHANGING THE TESTER FLUID .....	11
<b>3. <u>OPERATION</u></b> .....	<b>13</b>
1. GENERAL .....	13
2. OPERATION PROCEDURE .....	13

## **LIST OF FIGURES AND TABLES**

	<b>PAGE</b>
Fig. 1. IDENTIFICATION LABEL .....	1
Fig. 2. LIMITED ONE YEAR WARRANTY .....	2
Fig. 3. 2311FA PRESSURE TESTER WITH A DIGITAL GAUGE .....	5
Fig. 4. IDENTIFICATION OF PARTS OF THE 2311FA PRESSURE TESTER .....	10
Table 1. PHYSICAL CHARACTERISTICS (APPROXIMATE) .....	6
Table 2. SPECIFICATIONS OF RECOMMENDED GAUGES .....	6



## INTRODUCTION

### 1. PUBLICATION BREAKDOWN

This user instruction manual establishes the standards of operation for the 2311FA Pressure Tester.

Its purpose is to provide sufficient information for the personnel unfamiliar with this Tester to understand this equipment, identify its parts, and operate it in accordance with proper procedures, operating techniques, precautions and limitations.

### 2. INFORMATION PROVIDED WITH THE UNIT

Besides this User Instruction Manual, the Tester is delivered with the items described below.

- A. The identification label, (Figure 1), located on the front bulkhead of the Test Set, provides the following information:

Manufacturer Name	
Designation of Equipment	
Equipment Part Number	
Equipment Model Number	Equipment Serial Number
Equipment Modification (if applicable)	Equipment Options (if applicable)



**Figure 1. IDENTIFICATION LABEL**

- B. Each new or re-certified unit is delivered with a Certificate that shows the date when the unit was tested by the manufacturer, its serial number, and when the next certification is due. This certificate confirms that the unit performed according to its design specifications.



### **3. RECERTIFICATION**

The Test Set P/N 101-00212 has a one-year recertification requirement. Maintenance required by this unit must be performed by qualified technicians in a shop equipped with the necessary tooling and facilities.



### LIMITED ONE YEAR WARRANTY

BARFIELD INC. ("BARFIELD") warrants only to the original Purchaser of this product from BARFIELD or an authorized distributor that this product will be free from defects in material and workmanship under normal use and service for one year after date of purchase. BARFIELD reserves the right, before having any obligation under this limited warranty, to inspect the damaged BARFIELD product, and all costs of shipping the BARFIELD product to BARFIELD for inspection shall be borne solely by the Purchaser. In order to recover under this limited warranty, Purchaser must make claim to BARFIELD within 60 days of occurrence, and must present acceptable proof of original ownership (such as a purchase order, invoice, warranty card registration, or other documentation BARFIELD deems acceptable) for the product. BARFIELD, at its option, shall repair or replace the defective unit covered by this warranty. Please retain the dated sales receipt as evidence of the original purchaser's date of purchase. You will need it for any warranty service. In order to keep this limited warranty in effect, the product must have been handled and used as prescribed in the instructions accompanying this product. This limited warranty does not cover any damage due to accident, misuse, abuse or negligence. This limited warranty is non-transferable and does not apply to any purchaser who bought the product from a reseller or distributor not authorized by BARFIELD, including but not limited to purchases from internet sites. This warranty does not affect any other legal rights you may have by operation of law. Contact BARFIELD at [www.Barfieldinc.com](http://www.Barfieldinc.com) or customer service at (305) 894-5506 for warranty service procedures.

#### DISCLAIMER OF WARRANTY

EXCEPT FOR THE LIMITED WARRANTY PROVIDED HEREIN, TO THE EXTENT PERMITTED BY LAW, BARFIELD DISCLAIMS ALL WARRANTIES, EXPRESS OR IMPLIED, INCLUDING ALL WARRANTIES OF MERCHANTABILITY AND/OR FITNESS FOR A PARTICULAR PURPOSE. TO THE EXTENT THAT ANY IMPLIED WARRANTIES MAY NONETHELESS EXIST BY OPERATION OF LAW, ANY SUCH WARRANTIES ARE LIMITED TO THE DURATION OF THIS WARRANTY. SOME STATES/PROVINCES DO NOT ALLOW LIMITATIONS ON HOW LONG AN IMPLIED WARRANTY LASTS, SO THE ABOVE LIMITATIONS MAY NOT APPLY TO YOU.

#### LIMITATION OF LIABILITY

REPAIR OR REPLACEMENT OF THIS PRODUCT, AS PROVIDED HEREIN, IS YOUR EXCLUSIVE REMEDY. BARFIELD SHALL NOT BE LIABLE FOR ANY SPECIAL, INCIDENTAL OR CONSEQUENTIAL DAMAGES, INCLUDING, BUT NOT LIMITED TO, LOST REVENUES, LOST PROFITS, LOSS OF USE OF SOFTWARE, LOSS OR RECOVERY OF DATA, RENTAL OF REPLACEMENT EQUIPMENT, DOWNTIME, DAMAGE TO PROPERTY, AND THIRD-PARTY CLAIMS, ARISING OUT OF ANY THEORY OF RECOVERY, INCLUDING WARRANTY, CONTRACT, STATUTORY OR TORT. NOTWITHSTANDING THE TERM OF ANY LIMITED WARRANTY OR ANY WARRANTY IMPLIED BY LAW, OR IN THE EVENT THAT ANY LIMITED WARRANTY FAILS OF ITS ESSENTIAL PURPOSE, IN NO EVENT WILL BARFIELD'S ENTIRE LIABILITY EXCEED THE PURCHASE PRICE OF THIS PRODUCT. SOME STATES/PROVINCES DO NOT ALLOW THE EXCLUSION OR LIMITATION OF INCIDENTAL OR CONSEQUENTIAL DAMAGES, SO THE ABOVE LIMITATION OR EXCLUSION MAYNOT APPLY TO YOU. THIS WARRANTY GIVES YOU SPECIFIC LEGAL RIGHTS AND YOU MAY ALSO HAVE OTHER RIGHTS THAT VARY FROM STATE TO STATE AND PROVINCE TO PROVINCE.

#### **BARFIELD INC.**

4101 NW 29th Street  
Miami, Florida 33142, USA

Form 7.5.3-13  
Dated 02/01/2011, Rev. 0

### **Figure 2. LIMITED ONE YEAR WARRANTY**



This page intentionally left blank.

## CHAPTER 1

### GENERAL INFORMATION

#### 1. PURPOSE OF THE UNIT

The Barfield Inc. 2311FA Pressure Tester fulfills the need for field-testing of aircraft pressure systems for both reciprocating and turbine engines as well as airframe pressure systems. It provides pressure for driving all types of pressure transmitters, warning switches, pressure-type torque (BMEP) indicators and for system leak testing in the 0-600 PSI range. The Tester is proof-tested to 1200 psi.

#### 2. DESCRIPTION

The Barfield Inc. 2311FA Pressure Tester (Fig. 3) consists of a cylinder equipped with a manually operated piston for obtaining the desired outlet pressure. A fluid reservoir, located on top of the cylinder, is connected through a control valve to the inside of the cylinder. A 1/8 NPT female outlet port is provided at the control valve for attachment to the unit or system to be tested. The Tester is portable, rugged, and accurate with a wide range capability. It is simple to operate, self-contained and, is both line and shop proven. Its dimensions and weight are listed in Table 1.

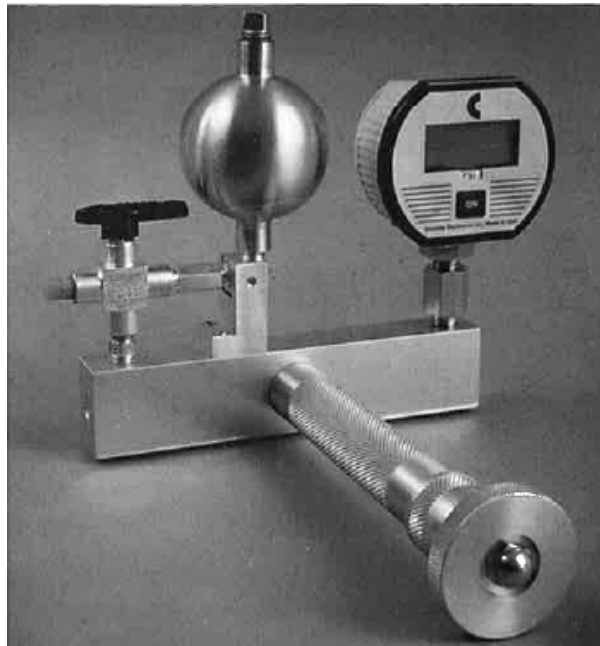

**Figure 3. 2311FA PRESSURE TESTER WITH A DIGITAL GAUGE (not included)**

**Table 1. PHYSICAL CHARACTERISTICS (APPROXIMATE)**

<u>DIMENSIONS</u>	<u>In.</u>	<u>Cm.</u>
Length	9.8	24.9
Width	7.8	19.8
Height	7.5	19.1
	<u>Lbs.</u>	<u>Kg.</u>
Weight	3.0	1.36

The dimensions listed exclude the Master Pressure Gauge connected at the Adapter (#14, Figure 4) which is sold separately. The Master Pressure Gauge depends on the user's requirements.

### 3. **RECOMMENDED GAUGES**

A Master Pressure Gauge is connected at the Adapter (#14, Figure 4) to the right side of the manifold body. Three types of gauges are recommended and available depending on the requirements of the user: standard, inspector test, and digital.

**Table 2. SPECIFICATIONS OF RECOMMENDED GAUGES**

TYPE	ACCURACY	PRESSURE RANGE	BARFIELD P/N
STANDARD (ANALOG)	± 2% Full Scale	0-60 PSIG	304-00003
		0-200 PSIG	304-00004
		0-600 PSIG	304-00005
INSPECTOR TEST (ANALOG)	± 0.5% Full Scale	0-60 PSIG	304-00100
		0-100 PSIG	304-00101
		0-160 PSIG	304-00102
		0-200 PSIG	304-00109
		0-300 PSIG	304-00103
		0-600 PSIG	304-00104
DIGITAL	± 0.25% Full Scale	0-200 PSIG	304-00006
		0-500 PSIG	304-00007
		0-7 Bar	304-00008

#### **4. RECOMMENDED FLUIDS**

The use of VITON (Fluoro -carbon) seals on the piston permits the use of any fuel, lubricating or hydraulic fluid except Skydrol or automotive hydraulic fluid. Any mineral or vegetable oil may be used with VITON seals. *The principal NON-COMPATIBLE fluids which are NOT to be used with VITON seals are: alcohols, aldehydes, amines, alkyl phosphate esters (Skydrol), ethers and ketones.*

**NOTE:** When changing from one type of fluid to another, complete disassembly and cleaning is necessary to prevent contamination of the system being checked, following the procedure of section 2.2.

#### **5. SHIPPING AND STORAGE**

##### A. Requirements

While there are no specific requirements for shipping and storage, normal care and no abusive handling will provide a longer life for the Tester. The metal components consist of brass, aluminum and corrosive resistant steel.

##### B. Spilled Chemicals

Any chemical spilled on the outside of the unit should be immediately removed. Care should be taken to prevent denting of the Shaft, which could cause restriction of Piston movement.

##### C. Extended Storage

If the Tester is to be stored for an extended period, remove the Vented Plug that is installed on the Reservoir, and replace with a solid plug (size: 1/4" NPT). Then, if the Tester is tipped or upset, the fluid will not spill out. However, the Vented Plug must be reinstalled before Tester use.



This page intentionally left blank.



## **CHAPTER 2**

### **FILLING AND FLUID-CHANGING PROCEDURES**

#### **1. FILLING THE TESTER WITH FLUID**

The Pressure Tester 2311FA is supplied empty for the convenience of the user, who can fill it with the liquid appropriate for its intended use (refer to Section 1.4, for the list of recommended fluids). For this first filling, or after the Tester has been emptied so its working fluid can be changed (as explained in the following section), applying the procedure below ensures that this task will be accomplished correctly, this is, without leaving any air bubbles trapped inside this equipment.

**NOTE:** Refer to Figure 4 to identify items referenced in this section.

1. Verify that the Master Gauge connected at the Adapter (#14) has sufficient range and accuracy for the test to be performed. Verify that it is securely installed in the Tester.

**NOTE:** Use Teflon tape if necessary to help prevent leaks.

2. Verify that the fluid to be used in the Tester is compatible with the unit or system to be tested (refer to Section 1.4, "Recommended Fluids").
3. Install a fitting (#18, not supplied) in the outlet of the Selector Valve (#9), which is a 1/8" NPT port. This fitting has to match with the hose or tubing that connects the Pressure Tester with the unit or system to be tested.
4. With the Selector Valve (#9) arrow pointing toward the Reservoir (#3), rotate the Screw Handle (#1) fully clockwise (CW).
5. Remove the Vented Plug (#16) from the Reservoir (#3). Fill the reservoir completely with appropriate fluid.

**NOTE:** Once filled, the Tester must be maintained in a position approximately level with the Reservoir (#3) up. If not, the fluid will spill through the Vented Plug (#16).

6. Rotate the Screw Handle (#1) fully counterclockwise (CCW) and add fluid until within 1/8 inch of full.
7. Turn selector valve 90° or halfway between the reservoir position and the outlet position.

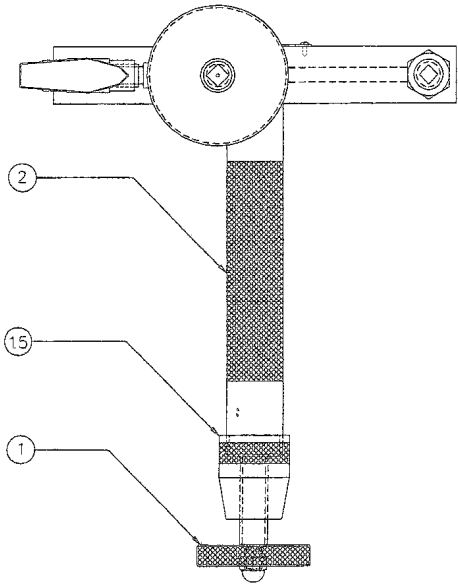

TOP VIEW

Item	Description
1	Piston, Shaft, and Handle Assembly
2	Manifold and Sleeve Assembly
3	Hydraulic Fluid Reservoir
4	Name Plate
5	Tank Fastening Spacer
6	Screw
7	Plug
8	Nipple
9	Selector Valve
10	Hex Long Nipple
11	Elbow
12	Cap Screw with Lock Washer
13	Set Screw
14	Adapter
15	Nut
16	Vented Plug
17	Cap
18	Outlet Fitting (Not Included)

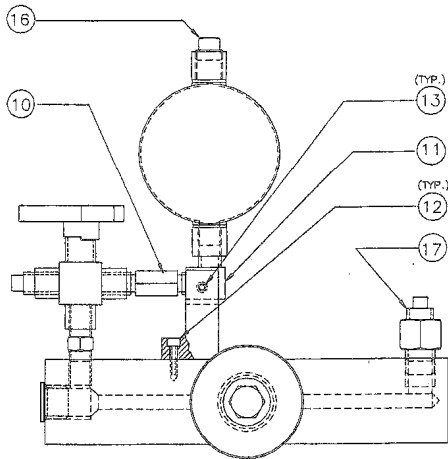

FRONT VIEW

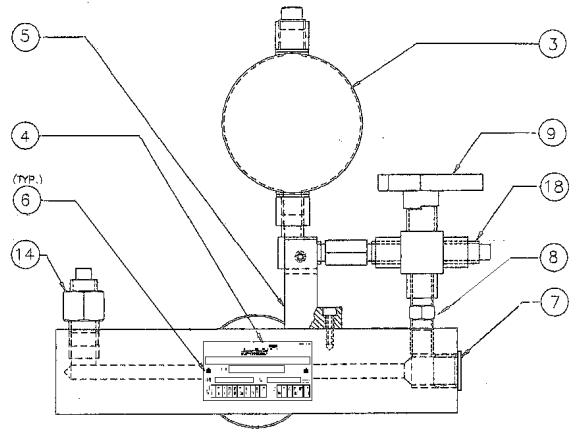

REAR VIEW

**Figure 4. IDENTIFICATION OF PARTS OF THE 2311FA PRESSURE TESTER**

8. Gradually turn the Screw Handle (#1) CW while observing the Master Gauge until the gauge reaches full scale.
9. Allow a few seconds for the pressure to stabilize; then observe the Master Gauge for one minute to note if leakage occurs.

NOTE: Depending on the viscosity of the fluid in the Tester, a slight leakage may occur. If leakage is no more than 5% of full scale in one minute, the accuracy of later test readings will not be affected. However, the leakage rate must be considered if subsequent tests involve leak detection.

10. Rotate the Screw Handle (#1) CCW until the Master Gauge reaches zero.

CAUTION: Do not allow Master Gauge to go below zero.

11. Turn the Selector Valve (#9) arrow toward the Reservoir (#3) and continue rotating the Screw Handle (#1) fully CCW.
12. Turn the Selector Valve (#9) arrow toward the Outlet Fitting (#18) and **slowly** turn the Screw Handle (#1) until fluid appears at that port.
13. The Tester is now ready for use.

## 2. CHANGING THE TESTER FLUID

In the event that the working fluid of the Tester needs to be replaced with a different one, follow the procedure below to make sure that there will be no residues of the previous liquid remaining inside the Tester, which can contaminate the new fluid.

NOTE: Refer to Figure 4 to identify items referenced in this section.

1. Remove the master test pressure gauge from Adapter (#14).

NOTE: To perform steps 2, 3, and 4 below, place the Tester inside a large plastic container to avoid spills of the hydraulic liquid.

2. Remove the Vented Plug (#16) from the Reservoir (#3).
3. Unscrew the Nut (#15) on the end of the cylinder and remove the Piston, Shaft, and Handle Assembly (#1) from the Tester
4. Drain all the liquid from the Piston, Shaft, and Handle Assembly (#1) and from the Manifold and Sleeve Assembly (#2), in the plastic container referred above.
5. Remove carefully the O-rings from the Piston, Shaft, and Handle Assembly (#1) to avoid scratching the Piston. Rinse the O-rings in hot running water, and blow dry.

NOTE: Do not use *alcohol* to clean the O-rings.

6. Rinse all metal parts in a solvent such as mineral spirits or naphtha. Then, rinse in hot running water.

NOTE: While cleaning and drying the Tester, turn the Selector Valve (#9) alternately between the Reservoir (#3) and the Outlet Fitting (#18) positions.

7. Drain all of the water. Then, rinse in alcohol and blow dry. Do not use *wood* alcohol.
8. Install the O-rings (cleaned and dried in step 5) on the Piston, Shaft, and Handle Assembly (#1).
9. Using the large Nut (#15), assemble the Piston, Shaft, and Handle Assembly (#1) together with the Manifold and Sleeve Assembly (#2). To do this, lubricate the Threaded Shaft (#1) with commercial Vaseline, and the O-rings with silicon grease.
10. Install the Master Gauge on the Adapter (#14) using Teflon tape.
11. Follow the procedure of Section 2.1, to fill the Tester with the new fluid.

## **CHAPTER 3**

### **OPERATION**

#### **1. GENERAL**

This chapter describes how to use the Pressure Tester 2311FA to deliver fluid, at the pressure needed by the user, to unit or system to be tested.

#### **2. OPERATION PROCEDURE**

After completing all steps listed in Section 2.1 (Filling Procedure), connect, with the appropriate hose or tubing, the Tester Outlet Fitting (#18, not included) to the unit or system to be tested. The size of the outlet port of the Selector Valve (#9) is 1/8" NPT. Then, perform the following steps.

**NOTE:** Refer to Figure 4 to identify items referenced in this chapter.

**CAUTION:** Make sure that the maximum working pressure of the Tester (600 psig), or the maximum working pressure of the Master Gauge being used, whichever is lowest, is not exceeded during the test.

1. While observing the Master Gauge and the system or unit-under-test, and with the Selector Valve arrow (#9) pointing toward the Outlet Fitting (#18), rotate slowly the Screw Handle (#1) clockwise (CW), until reaching the desired testing pressure. Lightly tap the Master Gauge when taking test readings.

**NOTE:** When connected to units or systems with long lines, the Shaft Screw (#1) may reach the fully CW position, before the target testing pressure is achieved. If this happens, perform steps 2 through 9, and then continue with the rest. If this situation does not happen, skip those steps and proceed directly to step 10.

2. Turn the Selector Valve arrow (#9) to point toward the Reservoir (#3).
3. Remove the Vented Plug (#16) from the Reservoir (#3).

**CAUTION:** Place a rag over the Vented Plug (#16) while removing it, to avoid possible exhaust spray.

4. Fill the Reservoir (#3) completely with the same type of fluid that was used during the previous steps.
5. Rotate the Screw Handle (#1) fully counterclockwise (CCW).
6. Refill the Reservoir (#3) until the level is approximately 1/8 inch under the top edge of the fitting.
7. Put the Vented Plug (#16) back in its place.

8. Turn the Selector Valve arrow (#9) to point toward the Outlet Fitting (#18).
9. Repeat step 1 above. If the required test pressure is not achieved yet, this cycle can be repeated as many times as needed.
10. After the test is completed, rotate the Screw Handle (#1) CCW until the Master Gauge reaches zero pressure. If this Handle reaches full CCW before the Master Gauge reaches zero, skip step 11 and perform step 12.

**NOTE:** Do not keep rotating the Screw Handle CCW after the gauge indicates zero pressure.

11. Turn the Selector Valve (#9) toward the Reservoir (#3) and disconnect the test line between the Tester and the unit or system that was tested.
12. If the Screw Handle (#1) reaches full CCW before the Master Gauge reaches zero, hold a rag over the Vented Plug (#16), because some overflow through it may occur, and turn the Selector Valve (#9) toward the Reservoir (#3). Rotate the Screw Handle (#1) fully CW.

**NOTE:** If a large volume of fluid was used during the test, to collect it back it is advisable to turn the Tester upside down, if the connecting hose allows it, and point the Vented Plug toward a container.

13. Return the Selector Valve (#9) to the outlet position and repeat step 10. This cycle can be repeated as many times as necessary, in order to collect back the fluid pumped during the test.

**NOTE:** The Plug (#7) is needed only due to a manufacturing step of the Manifold (#2). This plug has no function in the operation of the Tester, and it is permanently attached to the Manifold. The user should not attempt to drive this Plug under any circumstance. This action could cause damage to the both parts, leading to leaks.