

➔ ADTS505 / DPS450 CASE

Heavy Duty Rugged Case
with Wheels

Protect Your Investment

Upgrade your Air Data Tester (M/N ADTS505 / DPS450) with a more robust case.

This new generation comes with wheels for easier handling and has a limited lifetime warranty.



Features:

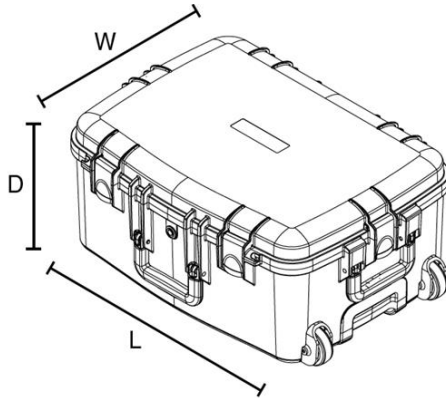

- ✓ Limited Lifetime Warranty
- ✓ Extendable pull handle
- ✓ Standard handles (4)
- ✓ Wheels
- ✓ Easy-open latches (4)
- ✓ Injection Molded Construction
- ✓ Watertight, airtight, and dustproof interior

Case Specifications:

Nominal INT Dimension	22.5"L x 16.2"W x 9.9"D 572L x 411 W x 251D mm
Base Depth	7.9" 201 mm
Lid Depth	2.0" 51 mm
Nominal EXT Dimension	25.4"L x 18.7"W x 11.6"D 645L x 475W x 295D mm
Approximate Weight	17.1 lbs 7.8 kg