

To buy, sell, rent or trade-in this product please click on the link below:  
<https://www.avionteq.com/Laversab-6300-M4-Pitot-Static-Tester>

**AvionTEq**

[www.avionteq.com](http://www.avionteq.com)



**MODEL 6300-M4 Rev. A5**

**USER'S MANUAL**

Document Number: 9043 REV A5

Date: June 30th 2014

## WARRANTY

Laversab Inc., warrants its products to conform to or exceed the specifications as set forth in its catalogs in use at the time of sale and reserves the right, at its own discretion, without notice and without making similar changes in articles previously manufactured, to make changes in materials, designs, finish, or specifications. Laversab Inc. warrants products of its own factory against defects of material or workmanship for a period of one year from date of sale.

Liability of Laversab Inc. under this warranty shall be limited to replacing, free of charge (FOB Houston, Texas), any such parts proving defective within the period of this warranty, but Laversab Inc. will not be responsible for transportation charges, consequential or incidental damages. No liability is assumed by Laversab for damages that are caused by misuse or abuse of the product.

The warranty of Laversab Inc. is not made for products manufactured by others which are illustrated and described in Laversab catalogs or incorporated in Laversab products in essentially the same form as supplied by the original manufacturer. Warranties of the original manufacturers supplant the warranty of Laversab Inc., but, in applicable instances, the latter agrees to use its best efforts to have original suppliers make good their warranties.

## **COPYRIGHT NOTICE**

Copyright (c) 2003-2006 by Laversab Inc. All rights reserved. The content of this manual may not be reproduced in any form by any means, in part or in whole, without the prior written permission of Laversab Inc.

## **DISCLAIMER**

No representations or warranties are made with respect to the contents of this user's manual. Further, Laversab Inc. reserves the right to revise this manual and to make changes from time to time in the content hereof without obligation to notify any person of such revision.

## REVISION HISTORY

Document No.	Release Date	Description
9043 REV A	10/20/2003	6300-M4 REV A User's Manual
9043 REV A2	03/05/2010	6300-M4 REV A2 User's Manual
9043 REV A3	03/23/2011	6300-M4 REV A3 User's Manual
9043 REV A4	07/22/2011	6300-M4 REV A4 User's Manual
9043 REV A5	06/30/2014	6300-M4 REV A5 User's Manual

## WARNING

THE 6300-M4 USES LINE VOLTAGES FOR ITS OPERATION WHICH ARE POTENTIALLY DANGEROUS. IMPROPER OPERATION OF THIS EQUIPMENT MAY RESULT IN PERSONAL INJURY OR LOSS OF LIFE. HENCE THE EQUIPMENT DESCRIBED IN THIS MANUAL SHOULD BE OPERATED ONLY BY PERSONNEL TRAINED IN PROCEDURES THAT WILL ASSURE SAFETY TO THEMSELVES, TO OTHERS AND TO THE EQUIPMENT.

BEFORE PERFORMING ANY MAINTENANCE, TURN THE POWER OFF AND DISCONNECT THE POWER CORD FROM THE POWER SOURCE.

ALWAYS USE A 3-PIN GROUNDED OUTLET AS YOUR AC POWER SOURCE

## TABLE OF CONTENTS

Warranty .....	i
Copyright notice, disclaimer .....	ii
Revision History .....	iii
Warning .....	iv
Section 1: Introduction .....	1
Section 2: Controls and Connections .....	2
2.1 Main Unit Top Panel .....	2
2.2 Remote Unit Top Panel .....	9
Section 3: Understanding the 6300-M4 .....	11
3.1 Start Up .....	11
3.2 Main Operating Screen .....	13
3.2.1 Displayed Parameters .....	13
3.2.2 Target Value Entry .....	19
3.2.3 Units Selection .....	21
3.2.4 Mode Selection .....	23
3.3 Leak Screen .....	25
3.4 Self Test Screen .....	27
3.5 Function Select Screen .....	29
3.5.1 Function 1: View Limits .....	29
3.5.2 Function 2: Set Limits .....	30
3.5.3 Function 3: Set Knots Rate .....	32
3.5.4 Function 4: View and Execute Profiles .....	32
3.5.5 Function 5: Setup Profiles .....	33
3.5.6 Function 6: Height Correction .....	33
3.5.7 Function 7: Set Ground .....	34
3.5.8 Function 8: Go To Ground .....	34
Section 4: Profiles .....	35
4.1 What is a Profile .....	35
4.2 Creating a Profile .....	37
4.3 Setting Up Hyperterminal .....	38
4.4 Downloading a Profile .....	39
4.5 Executing a Profile .....	40
Section 5: Typical Use .....	42
Section 6: Calibration .....	45
6.1 Equipment .....	45
6.2 General Notes .....	45
6.3 Ps Calibration .....	46
6.4 Pt Calibration .....	47

## TABLE OF CONTENTS (contd.)

Section 7: Maintenance .....	51
Section 8: Communication Interface .....	52
8.1 RS232 Serial Interface .....	52
8.2 Communication Syntax .....	52
Appendix A: Error Codes .....	55
Appendix B: Specifications .....	56
Appendix C: Repair and Return Policies .....	57

## SECTION 1

### INTRODUCTION

Note: Pt = Pitot and Ps = Static

The model 6300-M4 is a high accuracy automated pressure controller, specifically designed for controlling air data parameters such as altitude, airspeed, Mach and climb. This instrument can also be used to control pressures in units of inHg and mbar. The 6300-M4 is equipped with internal pressure and vacuum pumps. The Remote unit is used to interface with the Main unit. The small size of the Remote unit allows it to be used in the cockpit of an aircraft.

The 6300-M4 has two high accuracy transducers that measure pressure in the range of 0 to 38 inHg absolute on the Ps (static) output, and 0 to 100 inHg absolute on the Pt (pitot) output. These transducers are designed to accurately measure the pressure of dry air over an ambient temperature range of -10°C to 50°C. The 6300-M4 is RVSM compliant.

The 6300-M4 allows the user to control altitude in feet or meters, climb in feet per minute or meters per minute, airspeed in knots, mach, mph and kmph. It also allows the user to control EPR on the pitot output.

The model 6300-M4 features programmable limits on altitude, airspeed, mach number, and climb rate. These limits are checked during data entry and thereby prohibit entry of erroneous target values. These limits are also checked continuously during operation, and if any of these is exceeded, the unit automatically takes abortive action.

The user has the ability to program into the 6300-M4 a profile of set-points to be controlled in a sequence. Once such a profile has been setup, the user can command the unit to move from one set-point to the next simply by pushing the 'GO' button. Up to 50 points can be stored in one profile. The 6300-M4 can store up to 20 such profiles in non-volatile memory at any one time.

Calibration of the unit is required only once a year. This process is the only scheduled maintenance function required on the 6300-M4.

The model 6300-M4 comes with an RS232 interface. This interface is mainly used to download profiles from a computer. Connect Power and the Remote, connect the Pitot and Static outputs to the aircraft, and the 6300-M4 is ready for use. It's high accuracy and ease of use make it the ideal Pitot Static Tester.



## SECTION 2

### CONTROLS AND CONNECTIONS

**Note:** Pt = Pitot and Ps = Static

#### 2.1 MAIN UNIT TOP PANEL

The model 6300-M4 top panel provides easy access to all the connections. Please refer to Figure 2.1.

##### [1] AC INPUT connector :

This is a 3-pin male circular connector. A power cord is provided with the 6300-M4. The circular connector end of the power cord needs to be connected here. The power requirement of the 6300-M4 is 90-260 VAC, 47-440 Hz with a maximum power consumption of 150 VA.

**Caution: Connecting incorrect power to the 6300-M4 will cause considerable damage**

##### [2] Fuse :

A 5x20 mm fuse is located inside the fuse holder. The fuse is a time-delay fuse with a rating of 2.0 amps, 250 Volts.

##### [3] AC On/Off switch :

This toggle switch connects (or disconnects) AC power between the AC INPUT connector and the 6300-M4. Even when this switch is ON, the 6300-M4 becomes operational only after the On/Off switch located on the right side of the Remote Unit is turned ON. (Push in to turn ON)

##### [4] Remote Unit connection:

The 6300-M4 is provided with a 50 foot remote cable to connect to the Remote unit. The male end of the remote cable is connected here on the top panel. The female end of the remote cable is connected to the Remote unit. This cable should be connected prior to applying power to the 6300-M4. This cable should not be disconnected while power is applied to the 6300-M4.

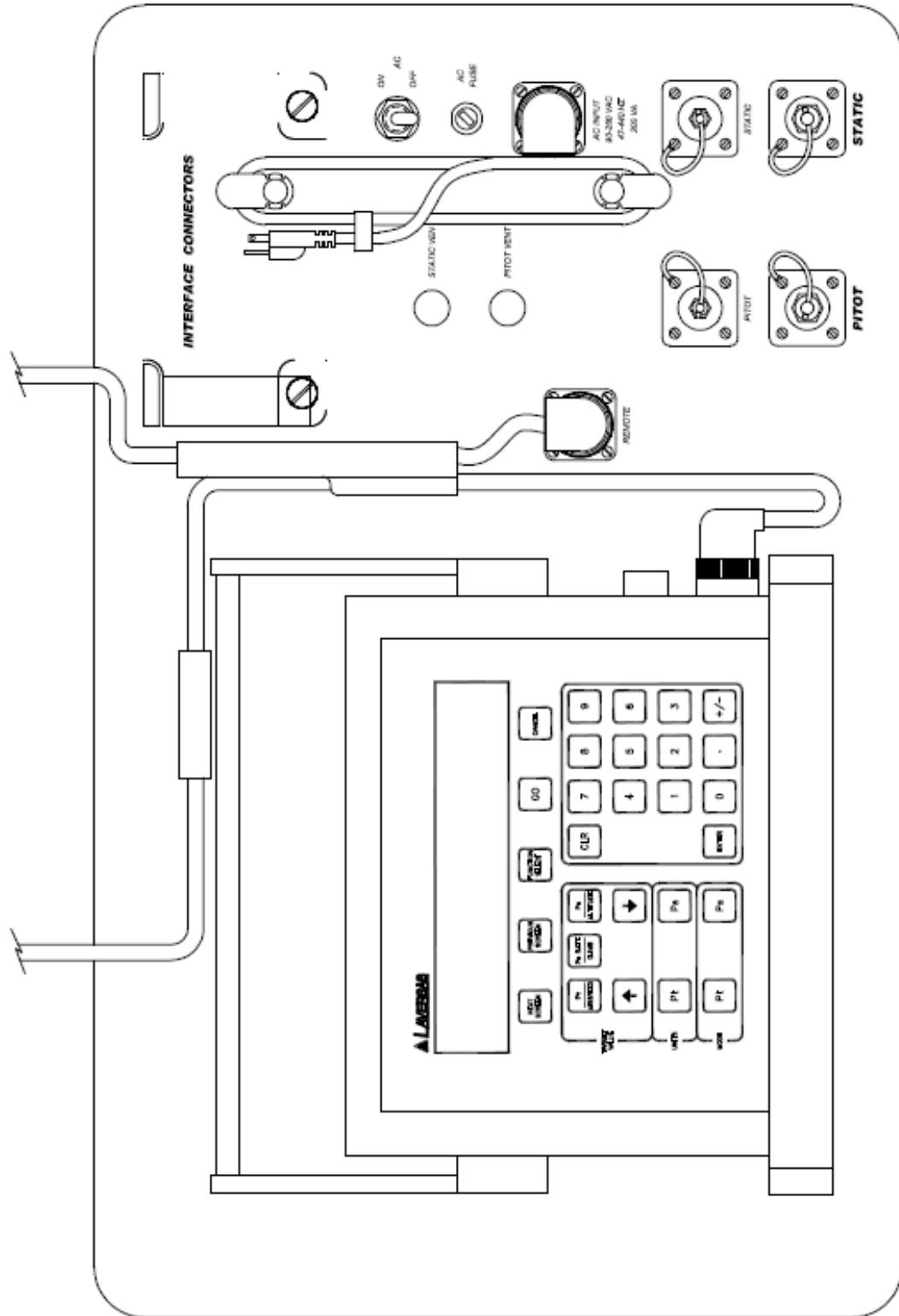

Figure 2.1 (A)

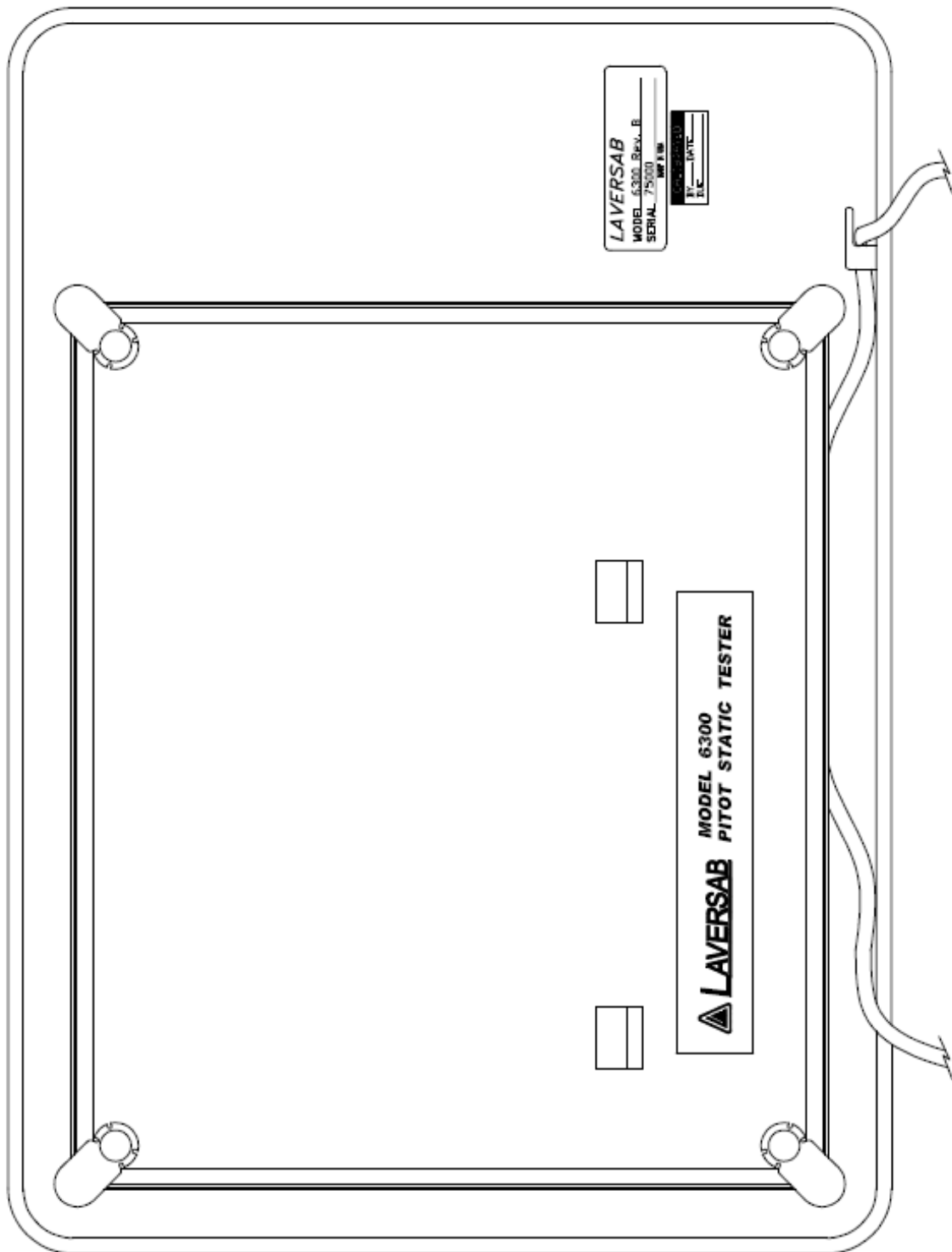

Figure 2.1 (b)

The remote cable is normally left connected to the 6300-M4 at the “Remote” connector on the top panel and is wrapped around four cord posts on the lid of the 6300-M4 case. The cord retainers on top of these posts swivel in either direction and latch at 180 degree positions, allowing easy wrapping and unwrapping of the remote cable. A cord clamp allows the cable to be held in place after it is wrapped. It is easier to wrap the remote cable around the posts after disconnecting the cable from the Remote unit.

If the remote cable needs to be disconnected and removed from the 6300-M4 completely for storage elsewhere then opening the Interface Connectors cover allows the cable to be dislodged from the cable guide.

#### **[5] Static ports :**

The Static output is provided on two ports that are internally connected. Both ports have #4 AN fittings. At least one of these ports must be connected through a hose to the Static port on the aircraft. The hose must be connected **after** performing the Self Test on the 6300-M4. The hose, once connected, must not be disconnected while the aircraft Static system is not at “Ground” level. An unused port must remain closed.

**Caution: Do not connect the Static hose to the Static port before performing the Self Test.**

**Caution: Do not disconnect the Static hose from the Static port unless the aircraft Static system is at “Ground” level.**

#### **[6] Pitot ports :**

The Pitot output is provided on two ports that are internally connected. Both ports have #3 AN fittings. At least one of these ports must be connected through a hose to the Pitot port on the aircraft. The hose must be connected **after** performing the Self Test on the 6300-M4. The hose, once connected, must not be disconnected while the aircraft Pitot system is not at “Ground” level. An unused port must remain closed.

**Caution: Do not connect the Pitot hose to the Pitot port before performing the Self Test.**

**Caution: Do not disconnect the Pitot hose from the Pitot port unless the aircraft Pitot system is at “Ground” level.**

**[7] RS232 interface connector:**

This connector is accessed by opening the “Interface Connectors” access panel. The connector is a standard DB-9 female connector used for a serial RS232 interface. It can be connected directly to the “COM” port of a standard PC to allow communication. This port is normally used for downloading “profiles” from a computer. Other remote communication with the 6300-M4 is also possible through this interface. Figure 2.2 shows the RS232 connector (6) with the panel removed. For more details on downloading profiles, please refer to Section 4. For more details on communication with the 6300-M4, please refer to Section 8.

**[8] IEEE-488 interface connector:**

This feature is currently not available on the 6300-M4.

**[9] Encoder interface connector:**

This feature is currently not available on the 6300-M4.

**[10] Static Vent :**

In the event that the 6300-M4 is in-operable due to a malfunction or due to loss of power, it is possible to vent the Static system manually. This is done using the metering valve labeled “Static Vent”. This valve is a positive shut-off valve. Opening this valve slowly will vent the Static output of the 6300-M4 to ambient pressure. While venting, care must be taken to ensure that the maximum climb rate of the aircraft connected to the tester is not exceeded. Also, the Pitot Vent may need to be used to maintain the airspeed within limits of the indicator on the aircraft.

**Caution: The Static Vent is NOT connected to the Pitot Vent. There is NO cross-bleed. When venting is completed, close the valve.**

**Caution: Do not over-tighten the valve as this may damage the seat of the valve.**

**[11] Pitot Vent :**

In the event that the 6300-M4 is in-operable due to a malfunction or due to loss of power, it is possible to vent the Pitot system manually. This is done using the metering valve labeled “Pitot Vent”. This valve is a positive shut-off valve. Opening this valve slowly will vent the Pitot output of the 6300-M4 to ambient pressure. While venting, care must be taken to maintain the airspeed within limits of the indicator on the aircraft.

**Caution: The Pitot Vent is NOT connected to the Static Vent. There is NO cross-bleed. When venting is completed, close the valve.**

**Caution: Do not over-tighten the valve as this may damage the seat of the valve.**

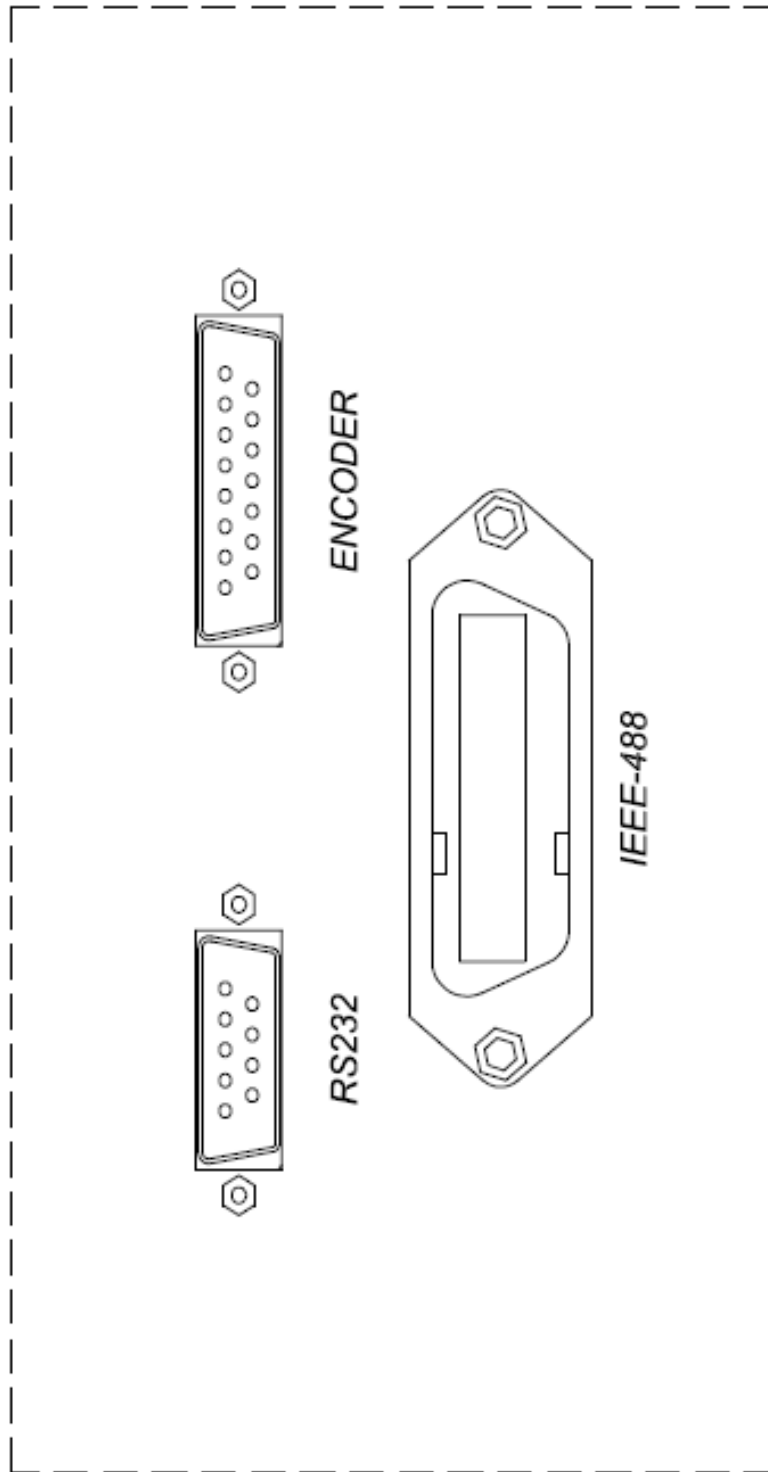

Figure 2.2

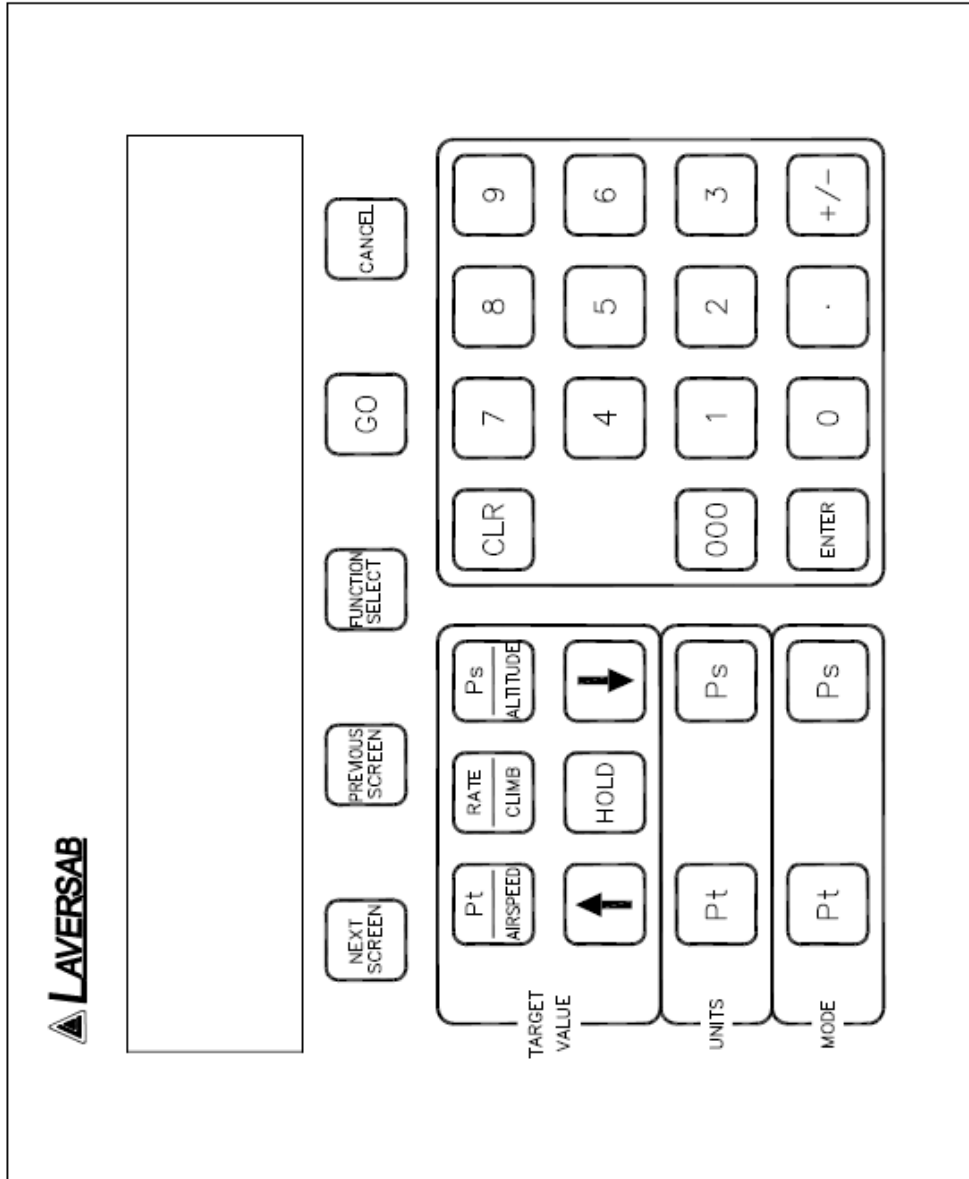

Figure 2.3

## 2.2 REMOTE UNIT TOP PANEL

Please refer to Figure 2.3 which shows the front panel of the Remote unit. The LCD display has 4 lines of 40 characters each. There are five function keys just below the display. **NEXT SCREEN** and **PREVIOUS SCREEN** are used to move between the different operating screens of the 6300-M4. At present there are only three upper level operating screens : Main, Calibrate and Self test.

The **FUNCTION SELECT** key is used to go into a screen which allows the user to choose any one of eight functions. The functions are:

1. View Limits
2. Set Limits
3. Set Knots rate
4. Execute profile
5. Setup profile
6. Height Correction
7. Set "Ground"
8. Go to "Ground"

These functions are described in detail in Section 3.

The **GO** key is used to execute all changes made through the Remote unit. After the changes have been 'ENTER' ed, they will flash on the screen until executed by the GO key. This allows for simultaneous execution of several changes in target values, modes, units etc.

The **CANCEL** key has multiple purposes. It is used to abort all changes that are flashing on the screen. It is also used to exit out of target value entry, unit selection and mode selection. It is used to exit out of other screens like Leak test and Function select. The CANCEL key is also used to acknowledge error messages or exit an executing profile.

### NUMERIC KEYS :

These keys are used for numeric entry of target values and other numeric data. The '+/-' key operates just like on a calculator and is used to enter negative values. This key must be used after entering the positive value, to make it negative.

The **CLR** key is used to clear the data entry field.

The **ENTER** key is used to accept numeric entries and also select units and modes.



## TARGET VALUE KEYS :

There are typically 3 parameters that the 6300-M4 controls - Altitude, Climb and Airspeed. Each parameter has its own target value key. The **Pt/AIRSPPEED** key is used to select Pt or Airspeed target value entry, the **Ps RATE/CLIMB** key is used to select Climb value entry, and the **Ps/ALTITUDE** key is used to select Ps or Altitude value entry. After selecting the target value key, the new value can be entered using the numeric keypad.

The **UP ARROW** and **DOWN ARROW** keys are used to “Jog” a target value. The arrow keys are also used to move between various choices during Unit selection and Mode selection. For more information, please refer to Section 3.2.2.

## UNITS SELECT KEYS :

Units can be selected independently for the Pt and Ps outputs. Pressing the **Pt UNITS** key will bring up the choices in Pt units onto the 4th line of the display. To exit from this selection mode, press CANCEL. To move between the choices use the arrow keys. There are nine Pt units in all. The cursor location is indicated by the blinking unit mnemonic. Once the cursor is on the desired units, press 'ENTER' to select that unit.

The **Ps UNITS** key brings up the choices for Ps units onto the 4th line of the display. Use CANCEL to exit this unit selection mode. Use the arrow keys to move between the choices. Use the ENTER key to select a choice. There are four Ps units to choose from.

For more information on Units Selection please refer to Section 3.2.3.

## MODE SELECT KEYS :

These keys are used to select between one of three operating modes. Pressing these keys brings up the selection of modes onto the 4th line of the display. The desired selection can be chosen by moving the cursor using the arrow keys and then pressing ENTER. The GO key will execute the entered selection. Modes can be selected independently for the Ps and Pt outputs.

For more information on Mode Selection please refer to Section 3.2.4.

## SECTION 3

### UNDERSTANDING THE 6300-M4

**Note:** Pt = Pitot and Ps= Static

The 6300-M4 is typically used to calibrate and check air data instruments like altimeters, climb indicators, and airspeed/ Mach indicators on an aircraft. It is also used to leak-check the Pitot/ Static system of an aircraft. This section will explain how to use the 6300-M4 to perform these functions.

#### 3.1 START UP

- Step 1: Connect the Remote cable to the Remote unit and the “Remote” connector on the main unit.
- Step 2: Check the ON/OFF switch on the Remote unit and make sure it is OFF.
- Step 3: Remove the protective caps from one each of the Pitot and Static outputs on the main unit. DO NOT connect any hoses yet. Make certain that the outputs are open to ambient. Close Pitot and Static Vent valves.
- Step 4: Connect the power cable to the “AC INPUT” connector on the main unit and connect the far end of the power cable to an AC supply.
- Step 5: On the Main unit, turn the AC On/Off switch ON. On the Remote unit, turn the ON/OFF switch ON.

The 6300-M4 will turn ON and the Remote unit will turn ON. The display will briefly show the sign-on screen and then go into the Main screen. The Main screen should appear as follows:

<b>Units:</b>		<b>knots</b>	<b>Feet/min</b>	<b>Feet</b>	
<b>Actual:</b>	<b>M</b>	<b>101.2</b>	<b>3500</b>	<b>1005</b>	<b>M</b>
<b>Target:</b>		<b>20.0</b>	<b>3000</b>	<b>0</b>	

The Actual values shown on line 2 will be different from the ones shown. The 4th line should be blank.

Before actually using the 6300-M4 to perform certain tasks, it is important to understand how to use the Remote unit to make the 6300-M4 do what you want. This section explains everything about the information that you see on the Remote unit and what it means, and

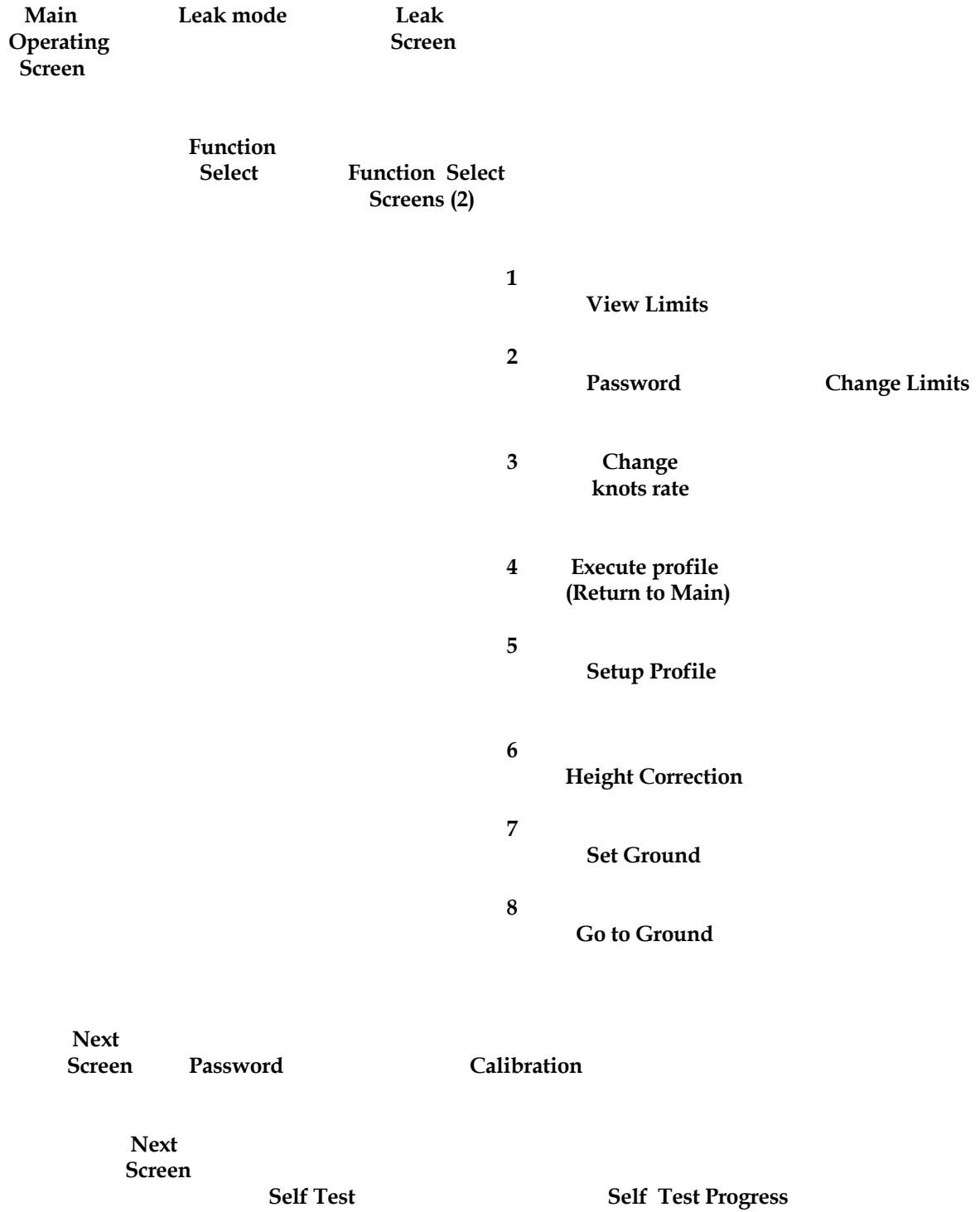

Figure 3.1

how to change all the parameters that are shown on the display. As we proceed through the explanations, it will become clearer as to how the 6300-M4 actually operates.

Interaction with the 6300-M4 is done through several different screens that are displayed on the Remote unit. All the screens are shown in Figure 3.1. Of the screens shown in Figure 3.1, the Self Test screen is used only at startup, all the Function Select screens are used only a few times during normal operation and also when first setting up the 6300-M4. The Calibrate screen is used only once a year by the calibration facility. During normal operation, the two screens that are used the most are the Main Operating screen (Main Screen) and the Leak Screen. All the different screens, except the calibration screen, are explained in this section. The Calibration screen is explained in section 6.

### 3.2 MAIN OPERATING SCREEN

Most of the operation of the 6300-M4 is done in the Main Screen. All the pertinent parameters are displayed on this screen. The screen is also used to change Target values, Units, and Modes. The following sub-sections explain the various uses of the Main Screen.

#### 3.2.1 DISPLAYED PARAMETERS

There are 11 basic parameters of importance while using the 6300-M4. Each of these parameters is displayed on the Main Screen. Each parameter is explained below and highlighted in a sample screen.

**Parameter 1. Pitot Units:** Unit of measurement for displaying the Pitot output. Normally, the Pitot unit used is 'Knots' for displaying airspeed. Other possible units for displaying the Pitot output are shown in section 3.2.3, which also explains how to select a particular unit. The currently selected Pitot unit is shown on the first line of the display (as shown below). The two values (101.2 and 20.0) that appear below it are in these units.

<b>Units:</b>		<b>knots</b>	<b>Feet/min</b>	<b>Feet</b>	
<b>Actual:</b>	<b>M</b>	<b>101.2</b>	<b>3500</b>	<b>1005</b>	<b>M</b>
<b>Target:</b>		<b>20.0</b>	<b>3000</b>	<b>0</b>	

**Parameter 2. Static Units:** Unit of measurement for displaying the Static output. Normally, the Static unit used is 'Feet' for displaying altitude. Other possible units for displaying the Static output are shown in section 3.2.3, which also explains how to select a particular unit. The currently selected Static unit is shown on the first line of the display (as shown below).

The two values (1005 and 0) that appear below it are in these units.

<b>Units:</b>		<b>knots</b>	<b>Feet/min</b>	<b>Feet</b>	
<b>Actual:</b>	<b>M</b>	<b>101.2</b>	<b>3500</b>	<b>1005</b>	<b>M</b>
<b>Target:</b>		<b>20.0</b>	<b>3000</b>	<b>0</b>	

**Parameter 3. Climb Units:** Unit of measurement for displaying the rate of change of the Static output, or Climb. Normally, the climb unit used is 'Feet/min' for displaying rate of change of altitude. These units cannot be independently chosen. Whatever the unit selected for the Static output, the climb unit is the per minute rate of that selected Static unit. If the Static unit selected is 'inHg' then the climb unit will be 'inHg/min'. The currently selected climb unit is shown on the first line of the display (as shown below). The two values (3500 and 3000) that appear below it are in these units.

<b>Units:</b>		<b>knots</b>	<b>Feet/min</b>	<b>Feet</b>	
<b>Actual:</b>	<b>M</b>	<b>101.2</b>	<b>3500</b>	<b>1005</b>	<b>M</b>
<b>Target:</b>		<b>20.0</b>	<b>3000</b>	<b>0</b>	

**Parameter 4. Pitot "Actual" value:** This is the current pressure measured at the Pitot output, displayed in the current units. In the sample screen shown below, the current pressure at the Pitot output is 101.2 knots. This value is updated every 0.25 seconds.

<b>Units:</b>		<b>knots</b>	<b>Feet/min</b>	<b>Feet</b>	
<b>Actual:</b>	<b>M</b>	<b>101.2</b>	<b>3500</b>	<b>1005</b>	<b>M</b>
<b>Target:</b>		<b>20.0</b>	<b>3000</b>	<b>0</b>	

**Parameter 5. Static "Actual" value:** This is the current pressure measured at the Static output, displayed in the current units. In the sample screen shown below, the current pressure at the Static output is 1005 Feet. This value is updated every 0.25 seconds.

<b>Units:</b>		<b>knots</b>	<b>Feet/min</b>	<b>Feet</b>	
<b>Actual:</b>	<b>M</b>	<b>101.2</b>	<b>3500</b>	<b>1005</b>	<b>M</b>
<b>Target:</b>		<b>20.0</b>	<b>3000</b>	<b>0</b>	

**Parameter 6. Climb “Actual” value:** This is the current rate of change of pressure measured at the Static output, displayed in the current units. In the sample screen shown below, the current rate of change of pressure at the Static output is 3500 feet/min.. This value is updated every 0.25 seconds.

<b>Units:</b>		<b>knots</b>	<b>Feet/min</b>	<b>Feet</b>	
<b>Actual:</b>	<b>M</b>	<b>101.2</b>	<b>3500</b>	<b>1005</b>	<b>M</b>
<b>Target:</b>		<b>20.0</b>	<b>3000</b>	<b>0</b>	

**Parameter 7. Pitot “Target” value:** This is the value that you command the 6300-M4 to achieve on the Pitot output. In the sample screen below, the 6300-M4 has been commanded to achieve a pressure of 20.0 knots on the Pitot output. The Pitot “Target” value is meaningful only when the Pitot output is in the “Control” mode. This is explained later in this section. How to change the Pitot “Target” value is explained in section 3.2.2.

<b>Units:</b>		<b>knots</b>	<b>Feet/min</b>	<b>Feet</b>	
<b>Actual:</b>	<b>M</b>	<b>101.2</b>	<b>3500</b>	<b>1005</b>	<b>M</b>
<b>Target:</b>		<b>20.0</b>	<b>3000</b>	<b>0</b>	

**Parameter 8. Static “Target” value:** This is the value that you command the 6300-M4 to achieve on the Static output. In the sample screen below, the 6300-M4 has been commanded to achieve a pressure of 0 Feet on the Static output. The Static “Target” value is meaningful only when the Static output is in the “Control” mode. This is explained later in this section. How to change the Static “Target” value is explained in section 3.2.2.

<b>Units:</b>		<b>knots</b>	<b>Feet/min</b>	<b>Feet</b>	
<b>Actual:</b>	<b>M</b>	<b>101.2</b>	<b>3500</b>	<b>1005</b>	<b>M</b>
<b>Target:</b>		<b>20.0</b>	<b>3000</b>	<b>0</b>	

**Parameter 9. Climb “Target” value:** This is the value that you command the 6300-M4 to achieve as the rate of change of pressure (climb/dive) on the Static output. In the sample

screen below, the 6300-M4 has been commanded to achieve a climb of 3000 Feet/min. on the Static output. A dive would be indicated by a negative value. The Climb “Target” value is meaningful only when the Static output is in the “Control” mode. This is explained later in this section. How to change the Climb “Target” value is explained in section 3.2.2.

<b>Units:</b>		<b>knots</b>	<b>Feet/min</b>	<b>Feet</b>	
<b>Actual:</b>	<b>M</b>	<b>101.2</b>	<b>3500</b>	<b>1005</b>	<b>M</b>
<b>Target:</b>		<b>20.0</b>	<b>3000</b>	<b>0</b>	

**Parameter 10. Pitot Mode:** The Pitot output can be in one of three modes -

Measure (“M”), Leak (“L”), or Control (“C”).

In the Measure mode, the pressure at the Pitot output is simply being measured and displayed as the “Actual” value in the current Pitot units. The pressure is not being changed by the 6300-M4. In this mode, the Pitot valve inside the 6300-M4 that is used to change the pressure at the Pitot output is pneumatically isolated from the Pitot output. In the Measure mode, the Pitot “Target” value is meaningless, since the 6300-M4 is not trying to achieve any specific target value.

The Leak mode is pneumatically identical to the Measure mode. When either (Pitot or Static) output is in Leak mode, the screen changes from the Main Operating screen to the Leak screen. The Leak screen is detailed in section 3.3.

When the Pitot output is in the Control mode the 6300-M4 is actually attempting to achieve the Pitot “Target” value. The Pitot control valve inside the 6300-M4 is now connected to the Pitot output and is actually increasing or decreasing the pressure to achieve and maintain the “Target” value.

For an explanation of how to change the Pitot mode between Measure, Leak and Control, please refer to section 3.2.4.

<b>Units:</b>		<b>knots</b>	<b>Feet/min</b>	<b>Feet</b>	
<b>Actual:</b>	<b>M</b>	<b>101.2</b>	<b>3500</b>	<b>1005</b>	<b>M</b>
<b>Target:</b>		<b>20.0</b>	<b>3000</b>	<b>0</b>	

**Parameter 11. Static Mode:** The Static output can be in one of three modes -

Measure ("M"), Leak ("L"), or Control ("C").

In the Measure mode, the pressure at the Static output is simply being measured and displayed as the "Actual" value in the current Static units. The pressure is not being changed by the 6300-M4. In this mode, the Static valve inside the 6300-M4 that is used to change the pressure at the Static output is pneumatically isolated from the Static output. In the Measure mode, the Static "Target" value is meaningless, since the 6300-M4 is not trying to achieve any specific target value.

The Leak mode is pneumatically identical to the Measure mode. When either (Pitot or Static) output is in Leak mode, the screen changes from the Main Operating screen to the Leak screen. The Leak screen is detailed in section 3.3.

When the Static output is in the Control mode the 6300-M4 is actually attempting to achieve the Static "Target" value. The Static control valve inside the 6300-M4 is now connected to the Static output and is actually increasing or decreasing the pressure to achieve and maintain the "Target" value.

For an explanation of how to change the Static mode between Measure, Leak and Control, please refer to section 3.2.4.

<b>Units:</b>		<b>knots</b>	<b>Feet/min</b>	<b>Feet</b>	
<b>Actual:</b>	<b>M</b>	<b>101.2</b>	<b>3500</b>	<b>1005</b>	<b>M</b>
<b>Target:</b>		<b>20.0</b>	<b>3000</b>	<b>0</b>	

**Split Screen:** The Main operating screen displays all 11 parameters conveniently. The screen can actually be divided into 2 halves, the left half shows all the 4 Pitot parameters, whereas the right half shows all the 7 Static parameters. The sample screens below shows this separation.

Pitot half

<b>Units:</b>		<b>knots</b>	<b>Feet/min</b>	<b>Feet</b>	
<b>Actual:</b>	<b>M</b>	<b>101.2</b>	<b>3500</b>	<b>1005</b>	<b>M</b>
<b>Target:</b>		<b>20.0</b>	<b>3000</b>	<b>0</b>	



Static half

<b>Units:</b>	<b>knots</b>	<b>Feet/min</b>	<b>Feet</b>	
<b>Actual:</b>	<b>M 101.2</b>	<b>3500</b>	<b>1005</b>	<b>M</b>
<b>Target:</b>	<b>20.0</b>	<b>3000</b>	<b>0</b>	

The Main operating screen will be used almost all the time during normal operation for commanding target values, viewing actual values, setting units and modes.

**Error Messages:** The Main screen is also used to display error conditions as they occur. The errors are displayed on the last (4<sup>th</sup>) line of the display, as shown below.

<b>Units:</b>	<b>knots</b>	<b>Feet/min</b>	<b>Feet</b>	
<b>Actual:</b>	<b>M 101.2</b>	<b>3500</b>	<b>1005</b>	<b>M</b>
<b>Target:</b>	<b>20.0</b>	<b>3000</b>	<b>0</b>	
<b>Error 5: Pitot target exceeds limits</b>				

**Profile Execution:** When a “profile” is being executed, the 4<sup>th</sup> line of the display will indicate the profile number and the point in the profile. A sample screen is shown below, where point number 12 of profile number 3 is being executed. Notice that this sample screen shows some of the values to be different from our previous sample screens. The essence of using profiles is that all the 7 parameters can be changed simply by moving to the next point in the profile, eliminating the need to perform a lot of data entry.

<b>Units:</b>	<b>knots</b>	<b>Feet/min</b>	<b>Feet</b>	
<b>Actual:</b>	<b>C 101.2</b>	<b>3500</b>	<b>1005</b>	<b>C</b>
<b>Target:</b>	<b>200.0</b>	<b>6000</b>	<b>5000</b>	
<b>Executing Profile 3.12 Lear-55 ADC</b>				

For more information on profiles, please refer to Section 4.

### 3.2.2 TARGET VALUE ENTRY

**Pitot target value :** A Pt or airspeed target value can be entered using the Pt/AIRSPEED key. On pressing this key the target value field for Pt gets put into reverse video. The 6300-M4 is now awaiting numeric entry from the operator. While this new value is being entered, the old target value is still effective and does not in any way affect the Pitot output. After the Pt/AIRSPEED key is pressed, the display will appear as shown below.

<b>Units:</b>		<b>knots</b>	<b>Feet/min</b>	<b>Feet</b>	
<b>Actual:</b>	<b>M</b>	<b>101.2</b>	<b>3500</b>	<b>1005</b>	<b>M</b>
<b>Target:</b>		<b>[REVERSE VIDEO]</b>	<b>3000</b>	<b>0</b>	

Use the numeric keys to enter the value. Use the +/- key to change the sign of the value. The 6300-M4 will beep on every key entry, and it will beep for a longer time period if extra invalid digits are entered. It is not necessary to enter the decimal point and the digit after the decimal point if that digit is "0". That is, if you want to enter the number "200.0" you may enter just "200" and leave out the "." And the "0". After entering "200" the display will appear as shown below.

<b>Units:</b>		<b>knots</b>	<b>Feet/min</b>	<b>Feet</b>	
<b>Actual:</b>	<b>M</b>	<b>101.2</b>	<b>3500</b>	<b>1005</b>	<b>M</b>
<b>Target:</b>		<b>[REVERSE VIDEO]</b>	<b>3000</b>	<b>0</b>	

If a mistake is made during entry, it can only be corrected by using the CLR key to clear the entry and re-entering the value. When the desired value is input into the value entry field, press ENTER and the value will blink. The trailing decimal and '0' will automatically get added. In the sample screen below the "200.0" is shown shadowed to indicate "blinking".

<b>Units:</b>		<b>knots</b>	<b>Feet/min</b>	<b>Feet</b>	
<b>Actual:</b>	<b>M</b>	<b>101.2</b>	<b>3500</b>	<b>1005</b>	<b>M</b>
<b>Target:</b>		<b>[SHADOWED]</b>	<b>3000</b>	<b>0</b>	

The value will continue to blink until the GO key is pressed. Only after the GO key is pressed, will the value become effective.

If you change your mind and want to abort the new value entry, press CANCEL to exit the value entry mode. You can press CANCEL even when the value is blinking. In the above example, if you were to press CANCEL the old Pt target value of 20.0 will remain effective.

If there is an error in the value being entered then that error will be displayed on line 4 of the display. To clear the error, enter CANCEL or CLR. This will also erase the erroneous value and the previous value will stay in effect. Most errors are caused because a value entered is outside the limits.

If the new value does not blink after pressing ENTER and no error message appears, then there is a communication problem between the Remote unit and the main unit. Please abort and contact the factory.

If GO is pressed after ENTERing the value, the 6300-M4 will try to achieve this new target value **ONLY IF** the Pitot output is in the CONTROL mode. Therefore, it is desired that both Pitot and Static values be entered so that both are blinking before the GO key is pressed.

**Static target value:** For entering Ps or altitude target values, press the Ps / ALTITUDE key and then follow the same process as described above.

**Climb target value:** For entering Ps rate or CLIMB target values, press the Ps RATE / CLIMB key and then follow the same process as described above.

**Note that while entering Climb values, it is NOT necessary to include the sign of the rate of climb. The 6300-M4 will automatically determine the direction of the rate of change. The displayed actual value will, however, indicate with a minus sign that the rate of change is a descent instead of a climb.**

### **Target Value Jog**

Each of the three target values can be jogged up or down in small increments by using the arrow keys. This is done to help the operator achieve a perfect reading on the instrument in the aircraft, by bumping the set-point in small increments.

To jog a value, select the value by pressing the appropriate target value key and then use the

arrow keys. The selected target value can be “jogged” with the arrow keys until any key other than the arrow keys is pressed. Each time the arrow key is pressed, the selected target value will be incremented (UP arrow) or decremented (DOWN arrow) by a specific amount, depending on the units of the target value.

The increments for the different units are as follows:

<u>Pt units</u>	<u>Ps units</u>	<u>Climb units</u>
Knots: 1	Feet: 1	feet/min: 10
mach: 0.001	Psin: 0.001	inhg/min: 0.01
PtinHg: 0.001	mtrs: 1	mtrs/min: 10
QcinHg: 0.001	mbar: 0.01	mbar/min: 0.1
Ptmb: 0.01		
Qcmb: 0.01		
mph: 1		
kmph: 1		
EPR: 0.001		

### 3.2.3 UNITS SELECTION

**Pitot Units:** There are nine units to select from on the Pt output. The units are: knots, Mach, Pt inHg, Qc inHg, Pt mbar, Qc mbar, miles per hour (mph), kilometers per hour (kmph), and Engine pressure ratio (EPR). EPR is defined as the ratio of Pt to Ps and is unit-less. Any of these units can be selected by pressing the Pt units key. The choices will appear on line 4 of the display, four at a time. The cursor is placed under the first choice. The arrow keys can be used to move the cursor. The UP ARROW key moves the cursor left, the DOWN ARROW key moves the cursor right. AS the cursor moves past the last selection, the next selection will be displayed. The sample screen below shows the different Pt units, with the cursor under “knots”.

<b>Units:</b>	<b>knots</b>	<b>Feet/min</b>	<b>Feet</b>	
<b>Actual:</b>	<b>M 101.2</b>	<b>3500</b>	<b>1005</b>	<b>M</b>
<b>Target:</b>	<b>20.0</b>	<b>3000</b>	<b>0</b>	
<b>Pt units :</b>	<b>knots, Mach, PtinHg, QcinHg, ....</b>			

When the cursor is moved past QcinHg , line 4 of the display will look like this:

<b>Pt units :</b>	<b>.... Mach, PtinHg, QcinHg, <u>P</u>tmb, ....</b>
-------------------	---

Each time the cursor is moved right, the displayed units will scroll left. When the cursor is moved to the last selection, line 4 will look like this:

**Pt units :** .... **Qc**mbar, **M**ph, **K**mph, **E**PR.

Select the desired units by moving the cursor to the unit of choice and then press ENTER. The new units will be displayed on the screen and will blink. Also, the actual and target values will get converted into the new units and the target value will blink. This is shown in the sample screen below where the units of Mach have been selected.

<b>Units:</b>		<b>Mach</b>	<b>Feet/min</b>	<b>Feet</b>	
<b>Actual:</b>	<b>M</b>	<b>0.136</b>	<b>3500</b>	<b>1005</b>	<b>M</b>
<b>Target:</b>		<b>0.064</b>	<b>3000</b>	<b>0</b>	

The unit selection will not become effective until the GO key is pressed. The 6300-M4 will return to the old units if the CANCEL key is pressed. .

**Static Units:** There are four Ps units to choose from: Feet, Ps inHg (Psin), meters, and mbar (Psmb). When a particular unit is selected, the units for climb automatically changes to selected units/minute. Any of these units can be selected by pressing the Ps Units key. Line 4 of the display will show all four units, with the cursor under "Feet". . The arrow keys can be used to move the cursor. The UP ARROW key moves the cursor left, the DOWN ARROW key moves the cursor right. The sample screen below shows the different Ps units, with the cursor under "Feet".

<b>Units:</b>		<b>knots</b>	<b>Feet/min</b>	<b>Feet</b>	
<b>Actual:</b>	<b>M</b>	<b>101.2</b>	<b>3500</b>	<b>1005</b>	<b>M</b>
<b>Target:</b>		<b>20.0</b>	<b>3000</b>	<b>0</b>	
<b>Ps units :</b>		<u><b>F</b></u> eet, <b>P</b> sin, <b>m</b> trs, <b>P</b> smb			

Select the desired units by moving the cursor to the unit of choice and then press ENTER. The new units will be displayed on the screen and will blink. Also, the actual and target values, both for Static and Climb will get converted into the new units and the target values will blink. This is shown in the sample screen below where the units of "PsinHg" have been selected.

<b>Units:</b>		<b>knots</b>	<b>PsinHg/min</b>	<b>PsinHg</b>	
<b>Actual:</b>	<b>M</b>	<b>101.2</b>	<b>8.345</b>	<b>28.986</b>	<b>M</b>
<b>Target:</b>		<b>20.0</b>	<b>10.000</b>	<b>29.054</b>	

The unit selection will not become effective until the GO key is pressed. The 6300-M4 will return to the old units if the CANCEL key is pressed. .

**It must be noted that the units change does not perform a conversion between the units of feet/minute or meters/minute to Ps inHg/min or Ps mbar/min. The target values for inHg/min and mbar/min are distinct from feet/min and meters/min. The values do get converted between feet/min and meters/min. They also do get converted between inHg/min and mbar/min.**

### 3.2.4 MODE SELECTION

**Pitot Mode :** The Pitot output has three modes of operation. The three mode are Measure (M), Leak (L) and Control (C). The power-up mode defaults to Measure (M). To change the mode press the Pt Mode key. The three modes will be displayed on line 4 of the display, with the cursor under the Measure mode. The UP ARROW key can be used for moving the cursor left and the DOWN ARROW key can be used to move the cursor right. The cursor wraps around the selections, that is, moving the cursor left past “MEAS” wraps it around to “CTRL”. The sample screen below shows the three mode choices displayed on line 4 of the display, with the cursor under “MEAS”.

<b>Units:</b>	<b>knots</b>	<b>Feet/min</b>	<b>Feet</b>	
<b>Actual:</b>	<b>M 101.2</b>	<b>3500</b>	<b>1005</b>	<b>M</b>
<b>Target:</b>	<b>20.0</b>	<b>3000</b>	<b>0</b>	
<b>Pt mode :</b>	<b><u>MEAS</u>, LEAK, CTRL</b>			

Move the cursor to the desired mode and then press ENTER. The selected mode is displayed on the screen and blinks until the GO key is pressed. The new mode will not become effective until the GO key is pressed. The sample screen below shows the selected Pitot mode as “LEAK”. Notice that the “L” on the left in line 2 is blinking.

<b>Units:</b>	<b>knots</b>	<b>Feet/min</b>	<b>Feet</b>	
<b>Actual:</b>	<b><u>L</u> 101.2</b>	<b>3500</b>	<b>1005</b>	<b>M</b>
<b>Target:</b>	<b>20.0</b>	<b>3000</b>	<b>0</b>	

**Important note:** When either the Pitot or Static Mode is changed to Control (C), BOTH Pitot and Static outputs are automatically changed to Control. During normal operation

you want both Static and Pitot outputs connected to the aircraft and both of them achieving a specific target value. Leaving one output in Measure or Leak and the other output in Control should be done only during a Leak check.

**Static Mode:** The Static output has three modes of operation. The three mode are Measure (M), Leak (L) and Control (C). The power-up mode defaults to Measure (M). To change the mode press the Ps Mode key. The three modes will be displayed on line 4 of the display, with the cursor under the Measure mode. The UP ARROW key can be used for moving the cursor left and the DOWN ARROW key can be used to move the cursor right. The cursor wraps around the selections, that is, moving the cursor left past "MEAS" wraps it around to "CTRL". The sample screen below shows the three mode choices displayed on line 4 of the display, with the cursor under "MEAS".

<b>Units:</b>		<b>knots</b>	<b>Feet/min</b>	<b>Feet</b>	
<b>Actual:</b>	<b>M</b>	<b>101.2</b>	<b>3500</b>	<b>1005</b>	<b>M</b>
<b>Target:</b>		<b>20.0</b>	<b>3000</b>	<b>0</b>	
<b>Ps mode :</b>	<b><u>MEAS</u>, LEAK, CTRL</b>				

Move the cursor to the desired mode and then press ENTER. The selected mode is displayed on the screen and blinks until the GO key is pressed. The new mode will not become effective until the GO key is pressed. The sample screen below shows the selected Static mode as "LEAK". Notice that the "L" on the right in line 2 is blinking.

<b>Units:</b>		<b>knots</b>	<b>Feet/min</b>	<b>Feet</b>	
<b>Actual:</b>	<b>M</b>	<b>101.2</b>	<b>3500</b>	<b>1005</b>	<b>L</b>
<b>Target:</b>		<b>20.0</b>	<b>3000</b>	<b>0</b>	

**Important note:** When either the Pitot or Static Mode is changed to Control (C), BOTH Pitot and Static outputs are automatically changed to Control. During normal operation you want both Static and Pitot outputs connected to the aircraft and both of them achieving a specific target value. Leaving one output in Measure or Leak and the other output in Control should be done only during a Leak check.

**The 'MEASURE' to 'CONTROL' transition**

When either a Pitot or Static output is changed from Measure or Leak to Control mode, a sequence of events takes place that needs explaining. Since the controlling portion of the

6300-M4 is isolated from the output during Measure or Leak modes, it will usually be at a pressure quite different from that at the output. Simply introducing the controlling section into the pneumatic system connected to the output will cause a surge in pressure (or vacuum) at the output. To prevent such a surge, the 6300-M4 measures the pressure at the output, shuts-off the output from the internal 6300-M4 pneumatics, and then controls the pressure within the internal control mechanism to match the pressure at the output. Once this is done, the 6300-M4 controlling section is connected to the output. This process is termed as Equalization.

While the 6300-M4 is undergoing this process, the term 'EQZN' is displayed on the main screen in place of the "Actual" value. The whole process usually takes about 15 seconds or less to complete. During the 'EQZN' process, the Main Operating screen will appear as shown below.

<b>Units:</b>		<b>knots</b>	<b>Feet/min</b>	<b>Feet</b>	
<b>Actual:</b>	<b>C</b>	<b>EQZN</b>	<b>EQZN</b>	<b>EQZN</b>	<b>C</b>
<b>Target:</b>		<b>20.0</b>	<b>3000</b>	<b>0</b>	

Once the Equalization process is complete, the Actual values appear on the Main Screen. Following the Equalization process, *only* when the actual value on the Static output is less than 2000 feet from Ground and the Pitot output is less than 150 knots, the 6300-M4 will automatically inject a small vacuum on the Static output and a small pressure on the Pitot output. This is done to determine the volume of the Pitot and Static system on the aircraft, so that the 6300-M4 can automatically adjust the gain of it's control mechanism. Due to this, the actual value will always increase in both altitude and in knots for about 5 seconds, regardless of the target value. Once this process is complete, the actual values will move towards the target values.

This process is part of the "Measure" (or "Leak") to "Control" transition, and will take place only when the transition to "Control" takes place within 2000 feet of Ground and 150 knots.

### 3.3 LEAK SCREEN

Although most of the operation of the 6300-M4 will be performed while in the Main Operating Screen described above, at times, the Leak Screen is also accessed. When either of the Pitot or Static outputs is put into the "Leak" mode (after pressing GO), the display changes to the Leak Screen. A sample Static Leak Screen is shown below.



<b>Start: 5000 feet</b>	<b>Instant Leak rate</b>
<b>Curr: 4990 feet</b>	<b>30 Feet/m</b>
<b>Timer: 00:20</b>	<b>Per min. Leak rate</b>
<b>Pt = 200 kts</b>	<b>WAIT Feet/m</b>

A sample Pitot Leak Screen is shown below.

<b>Start: 200.0 kts</b>	<b>Instant Leak rate</b>
<b>Curr: 199.5 kts</b>	<b>1.5 knots/m</b>
<b>Timer: 00:20</b>	<b>Per min. Leak rate</b>
<b>Ps = 0 feet</b>	<b>WAIT knots/m</b>

The parameters shown in the Leak Screen are:

- Start: This is the reading at which the leak test was started.
- Curr: This is the current reading of the output being leak checked
- Timer: Shows the elapsed time of the leak test in minutes and seconds
- Pt: (Ps:) Shows the actual value of the output that is **not** in leak test.
- Instant Leak rate: Shows the instantaneous rate at which the output is leaking. For the Static leak check this number is updated every 0.25 seconds and shows “0” for leaks less than 20 ft/min. For the Pitot leak check this number is updated every 3 seconds.
- Per min. leak rate: This is the amount the output has leaked in the past full minute. It is updated at the end of every minute on the timer. Until the first minute has elapsed it shows “WAIT”.

While in the Static Leak Screen, if the leak ever exceeds 2000 ft/min, the 6300-M4 will automatically trip out of the Leak mode and revert back to Control mode. It will then display a message as follows:

<p><b>Static leak exceeds 2000 ft/min. Returning STATIC to Control Mode. Please press “GO”</b></p>
--

While in the Pitot Leak Screen, if the leak ever exceeds 50 knots/min, the 6300-M4 will automatically trip out of the Leak mode and revert back to Control mode. It will then display a message as follows:

**Pitot leak exceeds 50 knots/min.  
Returning PITOT to Control Mode.  
Please press "GO"**

When either of these warning messages is displayed, press GO, which will bring up the Main Operating Screen. At this point it is recommended to go back to GROUND and to Measure mode on both outputs and fix the leak before proceeding further.

**It is important that each output be put into the Leak mode independently. That is, when the Pitot system of the aircraft needs to be checked for leaks, only the Pitot output should be in Leak mode, keeping the Static output in Control mode. When the Static system of the aircraft needs to be checked for leaks, only the Static output should be in Leak mode, keeping the Pitot output in Control mode.**

Pressing the CANCEL key allows you to exit from the Leak Screen, back to the Main Operating Screen. If the mode prior to entering the Leak mode was Control then the 6300-M4 will revert back to Control mode on exiting the Leak Screen.

### **3.4 SELF TEST SCREEN**

As part of the start up procedure, it is recommended that a Self Test be performed on the 6300-M4. Before performing the Self Test you must follow the start up procedure explained in section 3.1. The Main Operating Screen must be displayed on the Remote unit. There should be no errors displayed on line 4 of the display. If there are errors on line 4 of the display, press CANCEL to clear each error as it appears, until line 4 is clear.

Now press NEXT SCREEN twice. The display will show the screen shown below.

**SELF TESTS  
Please vent Pitot and Static ports  
to ambient, then press "GO"**

There are seven tests performed on the system. These tests check every subsystem for acceptable operation. If a malfunction is detected in any part of a subsystem, that subsystem is flagged as defective. Once a defective subsystem is detected, the self test function is aborted. Therefore, if more than one subsystem is defective, the first defective subsystem will cause the tests to abort, thereby preventing the user from detecting the flaws in the other malfunctioning subsystems.

The tests are performed on the following subsystems:

1. System ROM.
2. System RAM.
3. Ps pressure measurement system
4. Pt pressure measurement system
5. Pressure and Vacuum pump assembly
6. Ps pressure control system
7. Pt pressure control system.

To start the Self Test, please make sure that the Pitot and Static outputs are open to ambient, and then press GO. The status of each test will be displayed on the screen as shown below.



**ROM OK**                      **RAM OK**  
**Ps measurement system OK**  
**Pt measurement system OK**

After the pump section test has passed successfully, the screen is cleared and the status of the remaining tests is displayed as shown below.



**Pump section OK**  
**Ps control system OK**  
**Pt control system OK. Tests successful.**

After the tests have been completed successfully, press the CANCEL key to return to the Main Operating Screen.

If any of the tests fail, then note the failure, turn OFF the unit and contact the factory.

### 3.5 FUNCTION SELECT SCREEN

There are 8 different functions that can be performed. These are:

1. View Limits
2. Set or Change Limits
3. Set or Change the knots rate
4. View or Execute profiles
5. Setup profiles
6. Height Correction
7. Set Ground
8. Go To Ground

Pressing the “Function Select” key on the keypad allows you to go into the function select screen which is shown below.

<b>Select function</b>	<b>( DN ARROW for functions 4 to 8 )</b>
<b>1. View limits</b>	
<b>2. Set limits</b>	
<b>3. Set knots rate ... now at 500.0 kts/min</b>	

If you want to select functions 4 through 8, press the Down Arrow key on the keypad to move to the screen shown below.

<b>Select function</b>	<b>( UP ARROW for functions 1 to 3 )</b>
<b>4. Execute profile</b>	<b>5. Set profiles</b>
<b>6. Height Correction</b>	<b>7. Set “Ground”</b>
<b>8. Go to “Ground”</b>	

Once in the correct screen, select a number to go to the desired function. An explanation of each of the functions is given below.

#### 3.5.1 FUNCTION 1: VIEW LIMITS

The 6300-M4 checks both the Target values and the Actual values to determine if they are within specific limits. These limits can be set by the user. To view these limits, you can press the Function Select key and then choose Function 1 (View Limits) by pressing “1”. The VIEW LIMITS screen appears as shown below.

<b>VIEW LIMITS</b>	
<b>1. max. knots = 500.0</b>	<b>4. max. feet = 50000</b>
<b>2. min. knots = -200.0</b>	<b>5. min. feet = -2000</b>
<b>3. max. mach = 1.000</b>	<b>6. max. ft/min.= 6000</b>

To exit from this screen, press CANCEL.

For an explanation of the limits please refer to the “Set Limits” function.

### 3.5.2 FUNCTION 2: SET LIMITS

To set the limits, press 2 on the Function Select screen. Access to the “Set Limits” screen is protected by means of a password. Enter the password followed by the ENTER key on the screen shown below.

<b>SET LIMITS</b>	
<b>Please enter password :</b>	<input style="background-color: black; color: black;" type="password"/>

The correct password will take you into the “Set Limits” screen shown below.

<b>SET LIMITS</b>	
<b>1. max. knots = 500.0</b>	<b>4. max. feet = 50000</b>
<b>2. min. knots = -200.0</b>	<b>5. min. feet = -2000</b>
<b>3. max. mach = 1.000</b>	<b>6. max. ft/min.= 6000</b>

There are six limit values that can be set. These limits are checked when a Target value is entered. If the target value exceeds any of the limits, an error is generated. The Actual values are also checked when the 6300-M4 is in the “Control” mode. If any of these limits is exceeded by a pre-defined amount, an error will be generated and the 6300-M4 will revert to “Measure” mode.

An explanation of each limit follows:

**1. Max. knots :** This defines the maximum airspeed that can entered as a Target value or generated as an Actual value. Typically this is set to the maximum airspeed that the instruments on the aircraft can tolerate. The maximum value for this limit is 1100 and the minimum is 0. A typical setting for this limit is 500.0

**2. Min. knots :** This limits is usually negative and it defines the maximum “Negative Qc” that the airspeed instruments on the aircraft can tolerate. In most cases it should be set to about “-200.0” since almost all airspeed indicators can tolerate at least that much negative Qc. Setting it any closer to “0.0” may cause the limit to be tripped very frequently. The maximum value for this limit is 0 and the minimum is -900.

**3. Max. Mach :** This limit is usually set to the maximum allowable Mach number that the aircraft can tolerate. The maximum value for this limit is 5.0 and the minimum is 0.1 A typical setting for this limit is 1.0.

**4. Max. Feet :** This limit is usually set to the maximum altitude that the aircraft instruments can tolerate. The maximum value is 80,000 and the minimum is 0. A typical setting for this limit is 50,000.

**5. Min. Feet :** This limit is usually set to the minimum altitude that the aircraft instruments can tolerate. It is usually a negative number. The maximum value for this limit is 80,000 and the minimum is -16,000. A typical setting for this limit is -2000.

**6. Max. Ft/min :** This limit is usually set to the maximum rate of climb that the aircraft instruments can tolerate. It is usually limited to the maximum indication on the Vertical Speed Indicator (VSI) on the aircraft. The maximum value for this limit is 25,000 and the minimum is 100. A typical setting for this limit is 6000.

To modify a limit, select the limit by entering its serial number (1 to 6). The entry field will be blanked and a new value can be entered into it, followed by the “ENTER” key. The value becomes effective as soon as it is entered. In the screen shown below, “1” was selected to modify the max. knots limit.

Note: To set a negative value, enter the positive value and then press the “+/-” key.

SET LIMITS	
1. max. knots = <input type="text"/>	4. max. feet = 50000
2. min. knots = -200.0	5. min. feet = -2000
3. max. mach = 1.000	6. max. ft/min.= 6000

The CLR key is used to clear the value entered. The CANCEL key is used to exit the SET

LIMITS screen.

### 3.5.3 FUNCTION 3: SET KNOTS RATE

Pressing “3” on the Function Select screen brings you into the “Set Knots Rate” screen. This screen is shown below.

<b>CURRENT RATE = 250.0 knots /min.</b> <b>NEW RATE = <input type="text"/> knots /min.</b> <b>min : 50 , max : 500</b>
--

The knots rate is the rate at which the Actual airspeed value is ramped towards the Target airspeed value. A typical knots rate value of 500.0 is ideal for most operations. Enter the desired value followed by the ENTER key. This will take you into the following screen which shows that a new value of 300.0 was entered. Press GO to return to the Main screen.

<b>Thank you. Press “GO” to continue.</b> <b>NEW RATE = 300.0 knots /min.</b>
--

### 3.5.4 FUNCTION 4: VIEW & EXECUTE PROFILES

To execute a profile, press Function Select and then press “4”. This will bring you back into the Main Screen as shown below. You will need to enter the profile number that you want to execute. A full explanation of profiles is given in Section 4.

<b>Units:</b>	<b>knots</b>	<b>Feet/min</b>	<b>Feet</b>	
<b>Actual: M</b>	<b>101.2</b>	<b>3500</b>	<b>1005</b>	<b>M</b>
<b>Target:</b>	<b>20.0</b>	<b>3000</b>	<b>0</b>	
<b>ENTER PROFILE NUMBER :</b>	<b><input type="text"/></b>			

Assuming you enter a profile number of “2.1”, followed by the ENTER key, the first point of profile # 2 will be displayed on the screen. Also, the name of the profile is shown here. This is shown in the screen below. The name of profile 2 is CJ1-RVSM. In this profile note that both Modes changed to “C”, and all three target values changed. These parameters were programmed as the first point of profile # 2. You will also notice that the number “2.1” is

flashing. This indicates that the current profile point is ready for execution and awaiting the "GO" key to be pressed. When the "GO" key is pressed, the 6300-M4 will execute the profile point, i.e. it will change to Control mode and move towards the desired targets.

<b>Units:</b>		<b>knots</b>	<b>Feet/min</b>	<b>Feet</b>	
<b>Actual:</b>	<b>C</b>	<b>101.2</b>	<b>3500</b>	<b>1005</b>	<b>C</b>
<b>Target:</b>		<b>100.0</b>	<b>5000</b>	<b>1000</b>	
<b>ENTER PROFILE NUMBER : 2.1 CJ1-RVSM</b>					

Once the targets have been achieved, you can move to the next profile point by pressing ENTER. Then, the parameter values in point 2 of profile # 2 will be displayed, the profile number will change to "2.2" and will again flash, awaiting the "GO" key.

If you want only to view the profile without executing it, then DO NOT press the "GO" key. Simply press the "ENTER" key to go to the next point in the profile. Each time you press the "ENTER" key, the next profile point will be displayed. When you press the "ENTER" key after the last point in the profile, the Main screen will revert back to its original setting prior to invoking Function 4.

At any time, to exit out of the profile viewing or execution function, press CANCEL and the screen will revert back to the last executed point.

### 3.5.5 FUNCTION 5: SETUP PROFILES

This function is used to load profiles into the 6300-M4 from a PC. A full explanation of how to load profiles into the 6300-M4 is provided in Section 4.. The following screen will come up when Function 5 is selected.

<p><b>PROFILE SETUP</b>  <b>Please stay in this screen and download</b>  <b>One or more profiles through the RS232</b>  <b>interface. On completion press "GO".</b></p>
---

Once the profiles have been loaded, press GO to exit this function.

### 3.5.6 FUNCTION 6: HEIGHT CORRECTION

This function allows the user to enter the difference in height between the 6300-M4 and Ground level. This value should normally be 0 unless the 6300-M4 is elevated to a height of more than 3 feet above ground level. A value of between 0 and 50 feet can be entered. The screen appears as shown below.



<p><b>Current Height Correction = 0 feet</b>  <b>New Height Correction = [REDACTED] feet</b>  <b>Enter new height (0-50) or press CANCEL</b></p>
--

**3.5.7 FUNCTION 7: SET GROUND**

The “Set Ground” function is used to indicate to the 6300-M4 the ambient “Ground” pressure. Before connecting the 6300-M4 to the aircraft, just after the Self Test has been performed, it is recommended that this function be invoked. The Pitot and Static ports must still be open to ambient when using this function. When the “GO” key is pressed in the screen shown below, the 6300-M4 will “memorize” the ambient pressure it measures, as the “Ground” pressure. This will be used later when the “Go To Ground” function is invoked.

<p><b>Press “GO” to Set Ground ;</b>  <b>or press “CANCEL” to exit.</b></p>
---

**3.5.8 FUNCTION 8: GO TO GROUND**

The “Go To Ground” function is used to bring the aircraft back down to “Ground”. The target altitude is set to the value “memorized” in the “Set Ground” function and the target airspeed is set to 20 knots and the 6300-M4 ramps towards these targets. Once these targets have been achieved, you must put the 6300-M4 into Measure mode on both outputs and only then disconnect the 6300-M4 from the aircraft. The “Go to Ground” screen is shown below.

<p><b>Press “GO” to Go To Ground ;</b>  <b>or press “CANCEL” to exit.</b></p>
---

When “GO” is pressed, the 6300-M4 shows the Main screen. This screen is shown below, with the new targets of 100 knots and 275 feet. This assumes that the “Ground” pressure was 275 feet when the “Set Ground” function was invoked.

<b>Units:</b>		<b>knots</b>	<b>Feet/min</b>	<b>Feet</b>	
<b>Actual:</b>	<b>C</b>	<b>101.2</b>	<b>3500</b>	<b>1005</b>	<b>C</b>
<b>Target:</b>		<b>20.0</b>	<b>5000</b>	<b>275</b>	

## SECTION 4

### PROFILES

Profiles are created in Microsoft Excel and downloaded into the 6300-M4 through the COM1 port on your PC using the Hyperterminal program that is normally available on all PC's.

#### 4.1 WHAT IS A PROFILE.

A profile is a set of up to 50 points that tell the 6300-M4 what you would want it to do at each point. Each point consists of 7 parameters: 1) Pitot units, 2) Pitot mode, 3) Pitot target value, 4) Static units, 5) Static mode, 6) Static target value and 7) Static rate (Climb) target value. These 7 parameters are defined by you in the Excel program.

A total of 20 such profiles can reside in the 6300-M4 at any time. Each profile is identified by a number between 1 to 20 and also a name which can have up to 12 characters. The profile number and the name are also part of the profile that is created in Excel.

A typical profile named "Sample" is shown below as it would appear in Excel.

	A	B	C	D	E	F	G
1	<b>Profile</b>						
2	<b>Sample</b>			<b>3</b>		<b>0</b>	
3	knots	Control	100.0	Feet	Control	0	6000
4	knots	Control	200.0	Feet	Control	0	6000
5	knots	Leak	200.0	Feet	Control	0	6000
6	knots	Control	100.0	Feet	Control	1000	6000
7	knots	Control	200.0	Feet	Control	5000	6000
8	knots	Control	300.0	Feet	Control	10000	6000
9	knots	Control	100.0	Feet	Control	18000	6000
10	knots	Control	100.0	Feet	Leak	18000	6000
11	knots	Control	100.0	Feet	Control	30000	6000
12	knots	Control	100.0	Feet	Control	50000	6000
13	<b>knots</b>	<b>Control</b>	<b>20.0</b>	<b>Feet</b>	<b>Control</b>	<b>Ground</b>	<b>6000</b>
14	<b>knots</b>	<b>Measure</b>	<b>20.0</b>	<b>Feet</b>	<b>Measure</b>	<b>Ground</b>	<b>6000</b>
15	<b>END</b>						

Row 1 always says "Profile". This indicates to the 6300-M4 that a profile is to follow.

Row 2 left cell shows the name of the profile. This profile is named "Sample". The name can have up to 12 alphanumeric characters. This name will show up on the 4<sup>th</sup> line of the

6300-M4 display when this profile is executed.

Row 2 middle cell shows the number of the profile. This profile has a number 3. This tells the 6300-M4 that this profile is to be loaded in as profile number 3. When profile 3 is executed on the 6300-M4, this "Sample" profile will be executed. This number can be any number between 1 and 20. When this profile is downloaded into the 6300-M4 it will overwrite the previous profile that was resident in the 6300-M4 as number 3.

Row 2 right cell shows the height correction. This should normally be zero.

Rows 3 through 14 are the points of the profile. This profile has only 12 points. For each of these points the columns contain the following information:

<u>Column</u>	<u>Information</u>
A	Pitot units
B	Pitot mode
C	Pitot target value
D	Static units
E	Static mode
F	Static target value
G	Rate target value

In the sample profile, Row 3, which is the first point in the profile, tells the 6300-M4 to go in Control mode to 100 knots on the Pitot side, and in Control mode to 0 feet at 6000 feet/min on the Static side.

Row 4 (point 2) makes the 6300-M4 go to 200 knots and 0 feet at 6000 ft/min.

Row 5 (point 3) puts the Pitot side into Leak mode while still keeping Static in Control at 0 feet.

Row 6 (point 4) puts the Pitot side back into Control and takes it down to 100 knots. The Static side is simultaneously moved up to 1000 feet at 6000 ft/min.

Row 7 (point 5) takes Pitot up to 200 knots and Static up to 5000 feet at 6000 ft/min.

Row 8 (point 6) takes Pitot up to 300 knots and Static up to 10,000 feet at 6000 ft/min.

Row 9 (point 7) takes Pitot down to 100 knots and Static up to 18,000 feet at 6000 ft/min.

Row 10 (point 8) keeps Pitot at 100 knots and puts Static into Leak mode while at 18,000 feet.

Row 11 (point 9) keeps Pitot at 100 knots and ramps Static in Control mode to 30,000 feet at 6000 ft/min.

Row 12 (point 10) keeps Pitot at 100 knots and ramps Static to 50,000 feet at 6000 ft/min.

Row 13 (point 11) takes Pitot down to 20 knots and ramps Static back to “Ground” at 6000 ft/min.

Row 14 (point 12) puts both Pitot and Static into Measure mode.

## 4.2 CREATING A PROFILE

1. Start with opening the “Profile Template.xls” file.
2. Do not change anything on Row 1.
3. On Row 2, left-most cell, replace “Template” with the name of your profile. Limit is 12 characters.
4. On Row 2, middle cell, replace “11” with a profile number between 1 and 20 that you would like this profile to be saved as, in the 6300-M4.
5. Do not change row 2 right-most cell.
6. In rows 3 through 50, change the cells as per the points you want to generate in your test. For entering Units and Modes use the drop down menu selections for those cells. If you do not use all the rows for your profile, select the cells in the unused rows up to row 50 and delete them, shifting the cells up. DO NOT delete rows 51, 52 and 53.
7. Format the cells with values so that they show the correct number of digits after the decimal point. For instance, knots values have 1 digit after the decimal, Mach values have 3 digits after the decimal. Format the cell just like a regular Excel cell with a number. The following table lists the digits after the decimal for the various units. The Static rate (Feet/min etc.) value has the same number of digits after decimal as the Static value.

Pitot units	Digits after decimal	Static units	Digits after decimal
Knots	1	Feet	0
Mach	3	Ps inHg	3
EPR	3	Meters	1
Pt inHg	3	Ps mb	2
Qc inHg	3		
Pt mb	2		
Qc mb	2		
Mph	1		
Kmph	1		

8. Check the values, units and modes in your profile to ensure they are all valid and correct. If you going into the Leak mode at any point, then make sure that you achieve that point in Control mode before you actually change to Leak mode. For example, if you want to perform a Leak at 18,000 feet, then you must have one point

in Control mode which takes the Static port to 18,000 feet, followed by another point where the Static port is put into Leak mode at 18,000 feet.

9. Caution: If you are using Mach on the Pitot side, make sure that while the Static side is moving from a low altitude to a higher altitude, the target Mach number must be kept low (about 0.200). After the higher altitude is achieved, the Mach number can be increased to the desired value. This must be done to prevent a high Mach number at a low altitude causing an excessive airspeed (knots) to be generated. For example, if you want to achieve 0.800 Mach at 30,000 feet, 35,000 feet and 40,000 feet then your profile points must be set up as follows:

Mach	Control	0.200	Feet	Control	30000	6000
Mach	Control	0.800	Feet	Control	30000	6000
Mach	Control	0.800	Feet	Control	35000	6000
Mach	Control	0.800	Feet	Control	40000	6000

Notice how the Mach is kept low until 30,000 feet is achieved. Then it is ramped to 0.800 which would be an acceptable airspeed. Once this first point is achieved you do not have to lower Mach again because for altitudes of 35,000 and 40,000 feet, the same Mach number would actually result in a lower airspeed and the unit will automatically control this without any damage to the aircraft instruments.

10. Now that the profile is complete, save the profile as an Excel file ( .xls file) using the name of the profile as the filename. Then save it again using the "Save As" command but this time change the file type (using the "Save as type:" drop-down selection) to "Text - Tab delimited". Use the profile name as the filename again. You will get many warnings from Excel about the incompatibility of this text file, but simply say "Yes" to all the warnings. Once you have saved the file as a text file, you will need to close the file. When you do this, many more warnings will pop up. Please say "yes" to all these too.
11. At the end, you should have two files for your new profile. One .xls file and one .txt file, both with the same filename. Your profile has been created.

### 4.3 SETTING UP HYPERTERMINAL

You download a profile into the 6300-M4 using the Hyperterminal program. At first you need to setup Hyperterminal. You only need to do this once.

1. Hyperterminal comes loaded in your PC as part of the accessories. Go into "All Programs", then select "Accessories", then select "Communication", then select Hyperterminal. It will ask you to setup a new connection. Create a new connection with the name "6300-M4". A dialog box named "Connect To" will appear. The bottom selection in this box is "Connect using". From the drop down menu in

“Connect using”, select “COM1”. Select “OK”. A new dialog box will open named “Com1 Properties”. Setup the Port Settings as follows:

Bits per second:	9600
Data Bits:	8
Parity:	None
Stop Bits:	1
Flow control:	None

Select “Apply”. Then select “OK”. This will take you into the “6300-M4 Hyperterminal” window.

2. Select “File”. Select “Properties”. A new dialog box “6300-M4 Properties” appears. Select the “Settings” tab. In the “Emulation” menu select “ANSI”. Select “OK”. Now you are back in the “6300-M4 Hyperterminal” window. Select “File”, select “Save”. Close this window. A warning appears, select “Yes”. Hyperterminal is now setup.
3. To verify that the 6300-M4 file is setup in Hyperterminal, select “All Programs” from the desktop, select “Accessories”, select “Communications”, select “Hyperterminal”. The “6300-M4” icon should appear. If it does not appear then you will need to repeat steps 1 and 2 above.

#### 4.4 DOWNLOADING PROFILES

1. Connect the one-to-one RS232 cable to the RS232 port on the 6300-M4. You will need to remove the access panel for this. Connect the other end of this cable to the COM1 port on your PC.
2. Turn on the 6300-M4 and select Function 5, Set Profiles. The following screen appears.

**PROFILE SETUP**

**Please stay in this screen and download  
One or more profiles through the RS232  
interface. On completion press “GO”.**

Stay in this screen until all profiles you would like to download have been downloaded.

3. Start the 6300-M4 file in Hyperterminal. On the task bar select “Transfer”. Then select “Send Text file”. The dialog box will open that allows you to select the .txt file

you want to transfer. Open this file. You will see the profile being downloaded as it is echoed back from the 6300-M4.

4. After the profile has completed downloading, the last section should say "PASS". If it does not then the profile did not download correctly. If no characters are echoed when you open the .txt file to download then you probably have a communication problem.
5. If you see "garbage" on the first line of the profile as it downloads then you should redo the download. This could happen on some systems on the very first profile you download during a session in Hyperterminal.
6. To download more profiles in the same session simply repeat step 3 from the point you select "Transfer". After all profiles you wish to download have been transferred, press GO on the 6300-M4. Check that the profile loaded properly by selecting Function 4 on the 6300-M4 and entering the profile number starting at step 1 (i.e. "18.1" to check profile 18). Step through the profile using only ENTER and check if the points match what you have setup on the PC as your profile.

#### 4.5 EXECUTING A PROFILE

On the 6300-M4, select Function 4: Execute profile. On line 4 on the Main screen, a profile number is required to identify the profile. This number is x.y where x is the profile number and y is the point number within that profile. Since a particular point can be specified, the user can start a profile at any point, not necessarily at point 1. 'x' can have a value between 1 and 20 and 'y' can have a value between 1 and 50.

When a profile number is entered using the ENTER key, the name of the profile will appear to the right of the profile number and the parameters of the particular point in that profile will be displayed on the screen in their respective locations. It will appear as if the user had entered all those parameters from the front panel. The value x.y will flash on line 4 of the display, indicating that the point is ready to be executed. To execute the point press 'GO'. To view the next point in the profile press 'ENTER'. As long as the profile point number is flashing, it will not be executed.

Some of the rules to follow and points to observe while executing profiles are:

1. Press CANCEL to abort a profile. If CANCEL is pressed while the system is moving towards a target value, it will continue to do so. Aborting a profile simply allows the user the freedom to perform all functions possible from the front panel with no restrictions. Operating within a profile restricts the user to follow the profile.

2. Press GO to execute the flashing profile point. Once the 6300-M4 achieves the state it has been commanded to go to, it will stay there until the next profile point is invoked (using ENTER) and executed (using GO).
3. Press ENTER to invoke the next profile point. All parameters of the point will be shown on the screen and the point number will flash on line 4. ENTER allows the user to view an entire profile without executing any point. It also allows the user to skip certain points if so desired.
4. Only the ARROW keys are effective during profile execution to allow the user to jog the profile's target values. A new target value cannot be entered while a profile is executing. The existing target value may be jogged up or down in fixed increments as described in section 3.2.2.
5. No other keys are effective. Changing units or modes or target values will require aborting the profile.
6. When a profile goes into leak mode, the Leak Screen will be displayed. The profile will stay in this screen until the user enters CANCEL to exit the leak screen. The 6300-M4 returns to the main screen where the user must press ENTER to invoke the next profile point.
7. When the last point in the profile is executed, pressing ENTER will cause line 4 of the display to be cleared. This will be the only indication that the profile has been completed.
8. Each profile can have up to 50 points. There can be 20 profiles resident in the 6300-M4 at any one time.
9. New profiles can be loaded any number of times. They have to be numbered 1 to 20 and will overwrite existing resident profiles with the same profile number.
10. Errors during profile execution will cause the profile to abort. It can be restarted by the user at the point where the error occurred, after the error is rectified.
11. If a particular test procedure requires more than 50 points, then these points can be split between 2 or more profiles. For instance, if a transponder test requires 80 points, then the first 50 points can be loaded as profile 1 and the remaining 30 points can be loaded as profile 2. When profile 1 has been completed at point 1.50, the 6300-M4 will stay at that point until the next command. The user can start profile 2.1 and execute the 51st point and continue through the remaining 30 points using profile 2.



## SECTION 5

### TYPICAL USE

This section assumes that the user has read Section 3 and understood the functioning of the 6300-M4. Please do not follow the sequence shown below without first reading Section 3.

The following steps show a typical use of the 6300-M4 for checking aircraft instruments.

1. Turn on the 6300-M4 and perform the Self Test (NEXT SCREEN twice). Hoses should be disconnected and at least one Pitot and one Static port must be open to ambient. Pitot and Static Vent valves must be closed.
2. With ports still open to ambient, Set Ground (Function 7)
3. Connect hoses between the 6300-M4 outputs and the aircraft. Plug all unused Pitot and Static ports on the aircraft and on the 6300-M4.
4. Select Function 8: Go To Ground. This will put both Pitot and Static into Control mode with targets of 20 knots and 185 feet (assuming your "Ground" was 185 ft.). Wait for the targets to be achieved.
5. Set the Pitot target to 200 knots and GO.
6. When Pitot achieves 200 knots, put ONLY Pitot into Leak mode, leave Static in Control mode.
7. If Pitot has a significant leak (more than 5 knots/min.) then first try and find the leak while the 6300-M4 is in the Leak screen. If you lose all airspeed while searching for the leak, cancel out of the Leak screen and go back to Step 6 and continue to search for the leak. If you need to disconnect ANY hoses on the aircraft or between the 6300-M4 and the aircraft, then
  - a. Go To Ground
  - b. Put both Pitot and Static in Measure mode.
  - c. Then disconnect hoses.
8. Only after the Pitot system is reasonably leak-tight, should you proceed to the next step.
9. Leave the Pitot target at 200 knots and set the Static target to 3000 feet above Ground. Both Pitot and Static outputs should be in CONTROL mode. Press GO.
10. When both Pitot and Static targets have been achieved, put ONLY Static into LEAK mode, leaving Pitot in CONTROL mode.
11. If the Static port has a significant leak (more than 100 feet/min.) then first try and find the leak while the 6300-M4 is in the Leak screen. If you lose significant altitude while searching for the leak, cancel out of the Leak screen and go back to Step 10 and continue to search for the leak. If you need to disconnect ANY hoses on the aircraft or between the 6300-M4 and the aircraft, then

- a. Go To Ground
  - b. Put both Pitot and Static in Measure mode.
  - c. Then disconnect hoses.
12. Only after the Static system is reasonably leak-tight , should you proceed to the next step.
13. Now that both Pitot and Static systems are reasonably leak-tight, start your checkout procedure for checking the instruments inside the aircraft. At this point you may want to execute the appropriate Profile for your test.

**Caution: During your tests, do not put either Pitot or Static output in MEASURE mode unless the aircraft is at "Ground". Use only the Control and Leak modes.**

14. After you finish the last point of your test procedure, select Function 8: "Go to Ground". If you are executing a profile, this should already be part of your profile. The targets will get set to 20 knots and 185 feet (Your Ground).
15. After the targets have been achieved, set both Pitot and Static outputs to **MEASURE** mode. This should be part of your profile.
16. Turn OFF the 6300-M4.
17. Disconnect the hoses from the aircraft and from the 6300-M4.

During your test procedure, if you lose power, the 6300-M4 will maintain the pressure. When power comes back on, the 6300-M4 and the aircraft will be at the same pressure as before except for pressure lost due to leaks in the system.

If the 6300-M4 behaves erratically for whatever reason, turn OFF the 6300-M4 using the ON/OFF switch on the Remote unit. Turn the unit back ON after 30 seconds and attempt to use the 6300-M4 again.

The 6300-M4 is capable of overcoming substantial leaks in the system. It is not capable of overcoming extremely large leaks. Therefore it is essential that the system be reasonably leak-tight before taking the aircraft to higher altitude or airspeed. When you do a leak check at high altitude, a leak of more than 2000 feet/min. will immediately cause the 6300-M4 to exit the Leak screen and go back into Control mode automatically. A message will indicate that a large leak exists. Go back to Ground and go through the leak test process shown above, to find and fix the leak before proceeding further.

It may be helpful to keep a copy of the procedure, shown in Figure 5.1, with the 6300-M4 to assist the operator while using the 6300-M4.

## 6300-M4 : TYPICAL USE

### STEP 0: PREP AIRCRAFT

- 0.1 Connect adapters and hoses to the aircraft, tape-up all unused ports on the aircraft.
- 0.2 Leave hose ends near the 6300-M4 but DO NOT connect to 6300-M4 yet.

### STEP 1: SELF TEST

- 1.1 Open at least one Pitot and one Static port on 6300-M4 to ambient. Close Vent valves.
- 1.2 Turn ON 6300-M4 and run SELF TEST (NEXT SCREEN twice; GO).

### STEP 2: SET GROUND

- 2.1 With ports still open SET GROUND (F-7 ; GO)

### STEP 3: LOW LEVEL LEAK CHECK

- 3.1 Connect hoses from aircraft to 6300-M4. Check Yellow and Green ends match.
- 3.2 GO TO GROUND (F-8 ; GO)
- 3.3 **Pitot Leak check:**
  - a. Airspeed Target = 200 knots; GO
  - b. Setup Pitot Mode = Leak ("L" flashing) wait for Pitot to stabilize at 200 knots; GO
  - c. If Pitot cannot achieve 200 knots or if Pitot Leak exceeds 50 kts/min. (warning message ) then GO TO GROUND, Go to MEASURE on BOTH Pitot and Static, then find the leak. Go back to Step 3.2
  - d. If Pitot leaks down to below 100 knots and leak has not yet been found then CANCEL out of Leak Screen, allow Pitot to "recharge" to 200 knots, then change Pitot back into Leak Mode and continue searching for the leak.
  - e. When Pitot is Leak tight, CANCEL out of Leak Screen and proceed to step 3.4
- 3.4 **Static Leak check:**
  - a. Airspeed at 200 knots; Altitude Target = 3000 feet above Ground; GO
  - b. Setup Static Mode = Leak ("L" flashing) wait for Static to stabilize at target; GO.
  - c. If Static cannot achieve target or if Static Leak exceeds 2000 ft/min. ( warning message) then GO TO GROUND, Go to MEASURE on BOTH Pitot and Static, then find the leak. GO TO GROUND, then go back to Step 3.4
  - d. If Static leaks down more than 1000 feet and leak has not yet been found then CANCEL out of Leak Screen, allow Static to "recharge" to target, then change Static back into Leak Mode and continue searching for the leak.
  - e. When Static is Leak tight, CANCEL out of Leak Screen and proceed to step 4.

### STEP 4: CHECKOUT AIRCRAFT INSTRUMENTS

- 4.1 Run Profile (F -4) or execute your Test Procedure to checkout cockpit instruments.
- 4.2 GO TO GROUND at the end of Profile or Test Procedure.
- 4.3 Turn off 6300-M4, then disconnect hoses.

Figure 5.1

## SECTION 6

### CALIBRATION

#### 6.1 EQUIPMENT:

This calibration procedure requires the following equipment:

1. Vacuum pump.
2. Pressure supply of clean, dry air at 35 psia
3. Pressure standard having accuracy of at least 0.002 inHg up to 32 inHg and an accuracy of at least 0.005 inHg from 32 inHg to 100 inHg.

#### 6.2 GENERAL NOTES:

The transducers inside the 6300-M4 are sensitive to the change in density of the medium being used. The unit must be calibrated with Dry Air only. Calibrating with Nitrogen or any medium other than Dry Air will give erroneous results.

Because the transducers are medium-sensitive, care must be taken to ensure that the hoses used in the calibration system do not out-gas. Normally, PVC hoses, or refrigeration type hoses have a tendency to out-gas. The ideal hoses to use are Teflon or Teflon-coated hoses because they have a very low absorption and out-gas coefficient. Stainless steel hoses may also be used.

If the wrong type of hoses are used, then the typical results obtained will show that the error increases as the pressure increases. Also, it is very unlikely that the repeatability of the indicated pressure will be less than 0.002 inHg at 100 inHg. If the system cannot achieve repeatability of 0.002 inHg or less, then the most likely cause is the out-gassing of hoses.

In the following sections, the instructions call for generating a pressure of 1.000 inHg abs. using the Pressure Standard. If your Standard cannot generate such a low pressure, then please generate as low a pressure as possible provided it is less than 4.0 inHg abs.

The 6300-M4 has a drift of typically 0.005 %FS per year. Therefore it needs to be calibrated once a year to perform adequately as a calibration standard for air data equipment.

### 6.3 Ps (Static) CALIBRATION:

**Step 1.** Connect the output of the Pressure Standard to the Static port on the 6300-M4. The pressure and vacuum sources are to be connected to the Pressure Standard and it is assumed that the Pressure Standard has a suitable control mechanism which can allow the user to control the pressure at its output.

**Step 2.** Turn on the 6300-M4 and allow it to warm up for about 30 minutes. Change the units to "PsinHg" on the Static side and "PtinHg" on the Pitot side. Refer to section 3.2.3 on how to change units. During the warm-up period, purge the system with Dry Air by cycling the pressure at the Static port between 38 inHg absolute and 1 inHg absolute (or lower), at least three times. Also, ensure that there are no leaks in the system

**Step 3.** After the warm-up period is over, using the Pressure Standard, generate a pressure of 1.000 inHg absolute. Allow the pressure to be stable at 1.000 inHg for 2 minutes and take the reading on the Static side (PsinHg) of the 6300-M4. This is the first of your "Before" calibration adjustment reading. It will indicate the zero drift since the previous calibration.

**Note:** If your Standard cannot generate 1.000 inHg abs., the lowest possible pressure below 4.000 inHg abs. will be acceptable.

**Step 4.** Generate a pressure of 38.000 inHg absolute, allow the pressure to stabilize for 2 minutes and take the reading on the Static side (PsinHg) of the 6300-M4. This is the second of your "Before" calibration adjustment reading. It will indicate the zero plus slope drift since the previous calibration. Leave the pressure at 38.000 inHg while you perform the next step.

**Note:** If your Standard cannot generate 38.000 inHg abs., any pressure between 32.000 and 38.000 inHg abs. will be acceptable.

If you do not wish to make a calibration adjustment, but just want to verify the accuracy of the 6300-M4, please skip to Step 10.

**Step 5.** To make a calibration adjustment for the Static port, on the 6300-M4, move to the the CALIBRATION screen using the NEXT SCREEN key and enter the password. The calibration screen appears as follows:

CALIBRATION			
	Pt inHg		Ps inHg
Vacuum:	1. _____		3. _____
F.S. :	2. _____		4. _____

**Step 6.** Ensure that the pressure generated by the Standard on the Static port is still 38.000 inHg. Select item '4' using the keypad on the remote unit and then enter the value 38.000 in item 4. This indicates the full scale point for the calibration. If you make an error while entering data, press "CLR". Do not press "CANCEL". You may re-enter the value any number of times.

**Note:** If your Standard cannot generate 38.000 inHg abs., any pressure between 32.000 and 38.000 inHg abs. will be acceptable. Enter the value of the generated pressure.

**Step 7.** Now generate a pressure of 1.000 inHg with the Standard. Allow the pressure to stabilize for 2 minutes, select item '3' using the keypad on the remote unit and then enter the value 1.000 in item 3. This indicates the vacuum point for the calibration. If you make an error while entering data, press "CLR". Do not press "CANCEL". You may re-enter the value any number of times.

**Note:** If your Standard cannot generate 1.000 inHg abs., the lowest possible pressure below 4.000 inHg abs. will be acceptable. Enter the value of the generated pressure.

**Step 8.** On the keypad of the remote unit, press "PREV SCREEN". The display will return to the Main Screen. **If you press "CANCEL" the calibration adjustment will become void.**

**Step 9.** Turn the 6300-M4 OFF, wait 30 seconds and then turn it back ON. The calibration adjustment is now complete for the Static port.

**Step 10.** Verify the calibration by generating pressures in approximately 10% increments and noting the 6300-M4 Static port (PsinHg) readings. Your calibration sheet will appear as shown in Figure 6.1.

#### **6.4 Pt (Pitot) CALIBRATION:**

**Step 1.** Connect the output of the Pressure Standard to the Pitot port on the 6300-M4. The pressure and vacuum sources are to be connected to the Pressure Standard and it is assumed that the Pressure Standard has a suitable control mechanism which can allow the user to control the pressure at its output.

**Step 2.** Turn on the 6300-M4 and allow it to warm up for about 30 minutes. Change the units to "PsinHg" on the Static side and "PtinHg" on the Pitot side. Refer to section 3.2.3 on how to change units. During the warm-up period, purge the system with Dry Air by cycling the pressure at the Pitot port between 100 inHg absolute and 1 inHg absolute (or lower), at least three times. Also, ensure that there are no leaks in the system

**Step 3.** After the warm-up period is over, using the Pressure Standard, generate a pressure of 1.000 inHg absolute. Allow the pressure to be stable at 1.000 inHg for 2 minutes and take the reading on the Pitot side (PtinHg) of the 6300-M4. This is the first of your “Before” calibration adjustment reading. It will indicate the zero drift since the previous calibration.

**Note:** If your Standard cannot generate 1.000 inHg abs., the lowest possible pressure below 4.000 inHg abs. will be acceptable.

**Step 4.** Generate a pressure of 100.000 inHg absolute, allow the pressure to stabilize for 2 minutes and take the reading on the Pitot side (PtinHg) of the 6300-M4. This is the second of your “Before” calibration adjustment reading. It will indicate the zero plus slope drift since the previous calibration. Leave the pressure at 100.000 inHg while you perform the next step.

**Note:** If your Standard cannot generate 100.000 inHg abs., any pressure between 60.000 and 100.000 inHg abs. will be acceptable.

If you do not wish to make a calibration adjustment, but just want to verify the accuracy of the 6300-M4, please skip to Step 10.

**Step 5.** To make a calibration adjustment for the Pitot port, on the 6300-M4, move to the the CALIBRATION screen using the NEXT SCREEN key and enter the password. The calibration screen appears as follows:

CALIBRATION		
	Pt inHg	Ps inHg
Vacuum:	1. _____	3. _____
F.S. :	2. _____	4. _____

**Step 6.** Ensure that the pressure generated by the Standard on the Pitot port is still 100.000 inHg. Select item ‘2’ using the keypad on the remote unit and then enter the value 100.000 in item 2. This indicates the full scale point for the calibration. If you make an error while entering data, press “CLR”. Do not press “CANCEL”. You may re-enter the value any number of times.

**Note:** If your Standard cannot generate 100.000 inHg abs., any pressure between 60.000 and 100.000 inHg abs. will be acceptable. Enter the value of the generated pressure.

**Step 7.** Now generate a pressure of 1.000 inHg with the Standard. Allow the pressure to stabilize for 2 minutes, select item ‘1’ using the keypad on the remote unit and then enter the value 1.000 in item 1. This indicates the vacuum point for the calibration. If you make an error while entering data, press “CLR”. Do not press “CANCEL”. You may re-enter the value any number of times.

**Note:** If your Standard cannot generate 1.000 inHg abs., the lowest possible pressure below 4.000 inHg abs. will be acceptable. Enter the value of the generated pressure.

**Step 8.** On the keypad of the remote unit, press "PREV SCREEN". The display will return to the Main Screen. **If you press "CANCEL" the calibration adjustment will become void.**

**Step 9.** Turn the 6300-M4 OFF, wait 30 seconds and then turn it back ON. The calibration adjustment is now complete for the Pitot port.

**Step 10.** Verify the calibration by generating pressures in approximately 10% increments and noting the 6300-M4 Pitot port (P<sub>tinHg</sub>) readings. Your calibration sheet will appear as shown in Figure 6.1.



Model: 6300-M4

Serial#: 74678

Full scale: Ps: 38 inHg  
Pt: 100 inHg

Last Calibrated date: 10/10/01

**CALIBRATION RESULTS**

**STATIC PRESSURE (Ps):**

<u>TEST POINT</u>	<u>AS FOUND</u>	<u>AS LEFT</u>	<u>DEVIATION</u>
	inHg	inHg	inHg
1. Vacuum	1.001	1.000	0.001
2. Fullscale	38.002	38.000	0.002

**PITOT PRESSURE (Pt):**

<u>TEST POINT</u>	<u>AS FOUND</u>	<u>AS LEFT</u>	<u>DEVIATION</u>
	inHg	inHg	inHg
1. Vacuum	1.002	1.000	0.002
2. Fullscale	100.005	100.000	0.005

**VERIFICATION RESULTS**

**STATIC PRESSURE (Ps)**

**PITOT PRESSURE (Pt)**

<u>APPLIED</u>	<u>DISPLAYED</u>	<u>APPLIED</u>	<u>DISPLAYED</u>
inHg	inHg	inHg	inHg
1.000	1.000	1.000	1.000
4.000	4.000	10.000	9.999
8.000	8.000	20.000	19.999
12.000	12.000	30.000	30.000
15.000	15.000	40.000	40.000
19.000	19.001	50.000	50.000
23.000	23.001	60.000	60.000
27.000	27.000	70.000	70.000
30.000	30.000	80.000	80.001
34.000	34.000	90.000	90.002
38.000	38.000	100.000	100.000

Calibrated by:

Date:

Figure 6.1 Sample calibration sheet

**SECTION 7**  
**MAINTENANCE**

Scheduled maintenance of the 6300-M4 includes calibration once a year. The calibration procedure is described in Section 6.

Apart from this there are no other scheduled maintenance requirements.

## SECTION 8

### COMMUNICATION INTERFACE

The model 6300-M4 is capable of communicating with a remotely located computer via the RS232 serial interface. Using this interface it is possible to perform all functions that are available on the front panel.

#### 8.1 RS232 SERIAL INTERFACE

The serial interface is a three wire interface using the signals RX, TX and GND. Each byte of data is sent in ASCII format using 8 bits per byte, with 1 stop bit, no parity at 9600 baud.

The pin-out of the interface is as follows:

- Pin 2 - Transmit (TX)
- Pin 3 - Receive (RX)
- Pin 5 - Signal ground (GND)

The baud rate, parity, bits per byte, and number of stop bits cannot be altered and is set to 9600, No parity, 8 bits and 1 stop bit respectively.

#### 8.2 COMMUNICATION SYNTAX

All commands to the 6300-M4 are two letter commands. Some commands are used both to read and write data. Others are used only to read data back from the 6300-M4. If a command is used to write data then it is followed by the equal sign followed by the data to be written. Each command must be terminated by a carriage return <CR>. Each value returned by the 6300-M4 is terminated by a <CR> .

<u>Command</u>	<u>Type</u>	<u>Description</u>																				
PA	R	Actual pitot value in current units																				
RA	R	Actual climb/ Ps rate value in current units																				
SA	R	Actual static value in current units																				
PT=n	R/W	Read/ Set Pt target value																				
RT=n	R/W	Read/ Set climb/Ps rate target value																				
ST=n	R/W	Read/ Set Ps target value																				
PJ=n	W	Jog up (n=0) or down (n=1) Pt target																				
RJ=n	W	Jog up (n=0) or down (n=1) rate target																				
SJ=n	W	Jog up (n=0) or down (n=1) Ps target																				
PU=n	R/W	Read/ Set Pt units as per following: <table border="1" style="margin-left: 40px;"> <thead> <tr> <th><u>n</u></th> <th><u>units</u></th> </tr> </thead> <tbody> <tr><td>1</td><td>knots</td></tr> <tr><td>2</td><td>mach</td></tr> <tr><td>3</td><td>Pt inHg</td></tr> <tr><td>4</td><td>Qc inHg</td></tr> <tr><td>5</td><td>Pt mb</td></tr> <tr><td>6</td><td>Qc mb</td></tr> <tr><td>7</td><td>mph</td></tr> <tr><td>8</td><td>kmph</td></tr> <tr><td>9</td><td>EPR</td></tr> </tbody> </table>	<u>n</u>	<u>units</u>	1	knots	2	mach	3	Pt inHg	4	Qc inHg	5	Pt mb	6	Qc mb	7	mph	8	kmph	9	EPR
<u>n</u>	<u>units</u>																					
1	knots																					
2	mach																					
3	Pt inHg																					
4	Qc inHg																					
5	Pt mb																					
6	Qc mb																					
7	mph																					
8	kmph																					
9	EPR																					
SU=n	R/W	Read/ set Ps units as follows: <table border="1" style="margin-left: 40px;"> <thead> <tr> <th><u>n</u></th> <th><u>units</u></th> </tr> </thead> <tbody> <tr><td>1</td><td>Feet</td></tr> <tr><td>2</td><td>Ps inHg</td></tr> <tr><td>3</td><td>meters</td></tr> <tr><td>4</td><td>Ps mb</td></tr> </tbody> </table>	<u>n</u>	<u>units</u>	1	Feet	2	Ps inHg	3	meters	4	Ps mb										
<u>n</u>	<u>units</u>																					
1	Feet																					
2	Ps inHg																					
3	meters																					
4	Ps mb																					
PM=n	R/W	Read/Set Pt mode to Measure (1), Leak (2), control (3)																				
SM=n	R/W	Read/set Ps mode to Measure (1), Leak (2), Control (3)																				
ER	R	Read current error ; 0 if no error																				

<u>Command</u>	<u>Type</u>	<u>Description</u>
L1=n	R/W	Read/set max. knots limit
L2=n	R/W	Read/set min. knots limit
L3=n	R/W	Read/set max mach
L4=n	R/W	Read/set max. altitude
L5=n	R/W	Read/set min. altitude
L6=n	R/W	Read/set max. altitude rate
KR=n	R/W	Read/set knots rate
PF=n	R/W	Read/set current profile point
GO	W	Command to execute current settings.
CN	W	Command to cancel current settings
IE=n	R/W	Read/set IEEE address
C1=n	R/W	Read/set Pt vacuum calibration point
C2=n	R/W	Read/set Pt fullscale calibration point
C3=n	R/W	Read/set Ps vacuum cal. point
C4=n	R/W	Read/set Ps fullscale calibration point
CC	W	Activate new calibration points after new values have is executed.
SF=0	R	Read the status of the Self Test last performed.
SF=1	W	Start the Self Test.
SG	W	Set 'Ground'
GG	W	Go To 'Ground'

**APPENDIX A**  
**ERROR CODES**

All errors are displayed on line 4 of the display when the 6300-M4 is in the Main screen. An error must be acknowledged before any other key entries are accepted. The error may be acknowledged either by pressing the CANCEL or the CLR key.

<u>ERROR CODES</u>	<u>DESCRIPTION</u>
1	Pressure exceeded 110 %FS on Pt output
2	Pressure exceeded 110 %FS on Ps output
3	Pt target value exceeds Qc limits
4	Pt target value exceeds mach limit
5	Ps rate target exceeds climb limit
6	Ps target exceeds altitude limits
7	Pt actual value exceeds Qc limit
8	Pt actual value exceeds Mach limit
9	Ps actual value exceeds altitude limits.
10	Unused
11	Profile error
12	Ps EQZN transducer error
13	Pt EQZN transducer error
14	Internal use only

**APPENDIX B**  
**SPECIFICATIONS**

**Static Output**

**Pressure function**

range: 0.3 to 42 inHg  
resolution: 0.001 inHg  
accuracy: 0.002 inHg

**Altitude function**

range: -4000 ft. to 100,000 ft.  
resolution: 1 foot  
accuracy: 2 ft. @ 0 ft.  
6 ft. @ 35,000 ft.  
12 ft. @ 50,000 ft.  
50 ft. @ 80,000 ft.

**Climb function**

range: 100 ft/min to 25,000 ft/min  
resolution: 1 ft/min  
accuracy: 1% of rate of climb

**Pitot Output**

**Pressure function**

range: 0.3 to 100 inHg  
resolution: 0.001 inHg  
accuracy: 0.005 inHg

**Airspeed function**

range: 0 to 1100 knots  
resolution: 0.1 knots  
accuracy: 2.4 knots @ 20 knots  
1.0 knots @ 50 knots  
<0.5 knots above 100 knots

**Mach function**

range: 0.0 to 5.0 Mach  
resolution: 0.001 Mach  
accuracy: 0.001 above 0.2 Mach

**EPR function**

range: 0 to 199  
resolution: 0.001  
accuracy: 0.002 typ.

**Power requirement**

90-260 VAC, 47-440 Hz., 150 VA

**Interfaces**

RS232

**Dimensions & weights**

Main unit: 22" x 14" x 9" / 45 lbs  
Remote unit: 7" x 8" x 2" / 1 lb.

**Environmental specs:**

Operating temp. 0° to 50°C  
Storage temp. -25° to 75°C  
Humidity: 5 to 95% non-condensing

## APPENDIX C

### REPAIR AND RETURN POLICIES

If it is determined that the product is defective, please call Laversab customer service department: (281) 325-8300 or fax (281) 325-8399 or e-mail [service@laversab.com](mailto:service@laversab.com) for further assistance.

Before shipping any equipment to Laversab for repair, please call the customer service department at (281) 325-8300 or fax (281) 325-8399 or e-mail [service@laversab.com](mailto:service@laversab.com). Please include a description of the problem that has been identified when returning defective equipment.

**Note: Please pack the 6300-M4 in a carton prior to shipping. Do not ship without proper packing. Laversab, Inc. will not be liable for damage to the 6300-M4 if it is shipped without proper packing.**