

To buy, sell, rent or trade-in this product please click on the link below:
<http://www.avionteq.com/Barfield-DPS-500-Pitot-Static-Test-Set.aspx>



DPS500	Digital Air Data Tester
DPS501	Digital Dual Channel Controller

USER INSTRUCTION MANUAL
M/N: DPS500, P/N: 101-01190
M/N: DPS501, P/N: 101-01191

Doc. P/N: 56-101-01190 / 01191
Revision B
May 7, 2009

BARFIELD, INC.



Corporate Headquarters
4101 Northwest 29th Street
Miami, Florida 33142
www.barfieldinc.com
Email: gsesales@barfieldinc.com

Barfield Inc. Confidential and Proprietary Information.

*This document and all the information contained herein is the sole property of Barfield Inc.
No intellectual property rights are granted by the delivery of this document or the disclosure of its content.
This entire document is **proprietary information** and shall **not** be reproduced or disclosed to a third party without the express written consent of Barfield Inc.
This document and its content shall not be used for any purpose other than that for which it is supplied.*

This page intentionally left blank.

This page intentionally left blank.



DPS500/DPS501 INSTRUCTION MANUAL

CONTACT INFORMATION

Users are requested to notify the manufacturer of any discrepancy, omission, or error found in this manual. Inquiries should include specific questions and reference the publication title, number, chapter, page, figure, paragraph, and effective date.

Please send comments to:

**TECHNICAL CUSTOMER SUPPORT - GSTE
BARFIELD, INC.
P.O. BOX 025367
MIAMI, FL 33102-5367
USA**

Telephone **(305) 894-5400**
 (800) 321-1039

Fax **(305) 894-5401**

Email gsesales@barfieldinc.com

This page intentionally left blank.



DPS500/DPS501 INSTRUCTION MANUAL

ATTENTION

Although every effort has been made to provide the end user of this equipment with the most current and accurate information, it may be necessary to revise this manual in the future. Please be sure to complete and return the enclosed **OWNER WARRANTY REGISTRATION CARD** to Barfield in order to validate the warranty and to ensure that you will receive updated information when published. You MUST have your name and address on file at Barfield as a registered user of this equipment, to be able to obtain the service covered by the warranty.

Visit the company website, <http://barfieldinc.com/>, for publication updates.

Please send the Registration Card to:

Barfield, Inc.
P.O. Box 025367
Miami, FL 33102-5367
USA

This page intentionally left blank.



DPS500/DPS501 INSTRUCTION MANUAL

REVISION RECORD

REV.	ECO #	REV. DATE	DESCRIPTION OF CHANGE
-	N/A	February 21, 1994	Initial Release
A	N/A	September 30, 1999	General Revision
B	260-00729	May 7, 2009	Updated Company logo and List of Approved Repair Facilities. Pages were renumbered.

This page intentionally left blank.



DPS500/DPS501 INSTRUCTION MANUAL

LIST OF APPROVED REPAIR FACILITIES

The manufacturer of this equipment does not recommend the user to attempt any maintenance or repair. In case of malfunction, contact the manufacturer, to obtain the list of approved repair facilities worldwide, ensuring that this equipment will be serviced using proper procedures and certified instruments. A Return Maintenance Authorization (RMA) number will be assigned during this call, to keep track of the shipment and the service.

BARFIELD PRODUCT SUPPORT DIVISION

Telephone (305) 894-5400
(800) 321-1039

Fax (305) 894-5401

Shipping Address:

Barfield, Inc.
4101 NW 29th Street
Miami, FL 33142
USA

Mailing Address:

Barfield, Inc.
P.O. Box 025367
Miami, FL 33102-5367
USA

GE Sensing

Telephone (713) 975 0547

Email: sensing@ge.com

Shipping Address:

GE Sensing
10311 Westpark Drive
Houston, TX 77042
USA

This page intentionally left blank.



DPS500/DPS501 INSTRUCTION MANUAL

TABLE OF CONTENTS

Contact Information
Attention Page
Revision Record Page
List of Approved Repair Facilities
Table of Contents
List of Figures and Tables

	PAGE
INTRODUCTION.....	1
1. PUBLICATION BREAKDOWN	1
2. INFORMATION PROVIDED WITH THE UNIT	1
3. RECERTIFICATION	2
CHAPTER 1: TEST SETS DESCRIPTION	3
1. OUTLINE AND PURPOSE OF THE TEST SETS	3
2. PARTS IDENTIFICATION	4
A. DPS500 Flightline Air Data Test Set.....	4
B. DPS501 Dual Channel Controller	5
C. Remote Handheld Terminal.....	8
D. Pressure / Vacuum Pump.....	9
3. DPS500/501 FEATURES DESCRIPTION	10
4. CONTROLS.....	12
CHAPTER 2: SPECIFICATIONS AND CAPABILITIES.....	19
1. PHYSICAL DATA.....	19
2. SPECIFICATIONS.....	19
3. ACCURACY (TYPICAL).....	20
4. REPEATABILITY	20
5. CONTROLLER PERFORMANCE	21
6. RATE CONTROL PRECISION	22
7. TEMPERATURE RANGES	22
8. DISPLAY UNITS	22
9. PRESSURE MEDIA.....	23
10. TRANSDUCERS.....	23
11. INPUT POWER.....	23
12. PRESSURE FITTINGS	24
13. WARM-UP REQUIREMENTS.....	24
14. PACKAGING LIST	24



DPS500/DPS501 INSTRUCTION MANUAL

TABLE OF CONTENTS (Continued)

	PAGE
CHAPTER 3: DPS500/501 SETUP AND CONFIGURATION	25
1. DPS500/501 SETUP	25
A. DPS500/501 Menu Setup	26
1. Setup Menu # 1	26
2. Setup Menu # 2	31
B. DPS500/501 Key Setup	37
1. MACH / Pt Key Setup	38
2. SPEED / Qc Key Setup	39
3. ALT / Ps Key Setup (Altitude Correction)	40
4. RATE TIMER Key Setup	41
5. LEAK MEASURE / CONTROL Key Setup	42
6. GROUND Key Setup	44
7. PRINT Key Setup	45
8. RATE Key Setup	46
9. Nudge Up (▲) and Nudge Down (▼) Keys Setup	47
2. DPS500/501 CONFIGURATION	49
A. DPS500/501 Configuration Menu	50
1. CONFIG Menu # 1	50
2. CONFIG Menu # 2	60
B. DPS500/501 Key Configuration	63
1. SPEED/Qc Key Config	64
2. RATE Key Config	64
3. RATE TIMER Key Config	64
4. GROUND Key Config	64
5. LEAK MEASURE/CONTROL Key Config	65
6. EXECUTE TEST PROGRAM Key Config	67
7. Nudge Up (▲) and Nudge Down (▼) Keys Config	68
8. - / 000 Key Config	69
CHAPTER 4: DPS500/501 OPERATION	71
1. DPS500/501 POWER CONNECTION	71
A. DPS500 AC Electrical Connection	71
B. DPS500 DC Electrical Connection (Optional)	72
C. DPS501 Controller Ac Electrical Connection	73
2. DPS500/501 INITIALIZATION AND SELF-TEST	74
3. DPS500/501 LEAK TESTING	77

DPS500/DPS501 INSTRUCTION MANUAL

TABLE OF CONTENTS (Continued)

	PAGE
4. DPS500/501 PNEUMATIC PRESSURE CONNECTION	79
A. DPS500 Flightline Test Set Connection	79
B. DPS501 Dual Channel Controller Connection	80
5. PHYSICAL POSITIONING	81
A. Manual Altitude Correction Setup	81
B. Altitude Correction through Limit Setup	83
6. DPS500/501 LIMIT PROTECTION SETUP	83
7. DPS500/501 AIRCRAFT LEAK TESTING	85
8. DPS500/501 AIRCRAFT TESTING	87
A. Preliminary Steps	87
B. Typical Operation	87
C. Quick Operation Using Nudge Keys	89
D. Mach Test and Constant Mach	91
E. True Airspeed Testing	92
F. Engine Pressure Ratio (EPR) Testing	92
CHAPTER 5: RECEIVING, SHIPPING, STORAGE	95
1. RECEIVING	95
2. SHIPPING	95
3. STORAGE	95
CHAPTER 6: SERVICING	97
1. INTRODUCTION	97
2. STANDARD SERVICEABILITY TEST	97
A. Controller Test	97
B. Pump Test	98
3. DPS500/501 FUNCTIONAL TEST	99
A. Key Pad Test	99
B. Controller Stability	99
CHAPTER 7: TROUBLESHOOTING	103
1. INTRODUCTION	103
2. WARNING MESSAGES	103
3. ERROR MESSAGES	105
4. SELF-TEST ERRORS	106
5. FAULT DIAGNOSIS	106
6. VENTING AFTER OVERPRESSURE	109

This page intentionally left blank.

DPS500/DPS501 INSTRUCTION MANUAL

LIST OF FIGURES AND TABLES

		PAGE
Figure 1	Owner Warranty Registration Card	1
Figure 2	Limited Warranty Statement Card	2
Figure 3	DPS500 Automated Flightline Air Data Test Set	4
Figure 4	Two views of the DPS501 Automated Dual Channel Controller.....	6
Figure 5	DPS500/501 Remote Handheld Terminal.....	8
Figure 6	DPS500 Pressure / Vacuum Pump Assembly.....	9
Figure 7	Remote and Local Keyboards	13
Figure 8	DPS500/501 Menu Setup Quick Reference Flowchart	36
Figure 9	Keys for which the Direct Key Setup capability is operational	37
Figure 10	DPS500/501 Key Setup Quick Reference Flowchart.....	48
Figure 11	DPS500/501 CONFIG Menu Quick Reference Flowchart	62
Figure 12	Keys for which the Direct Key CONFIG capability is operational	63
Figure 13	Direct Key Configuration Reference Flowchart	70
Figure 14	DPS500 Power Connection.....	71
Figure 15	DPS501 Power Connection.....	73
Figure 16	DPS500 Pneumatic Pressure Connections	79
Figure 17	DPS501 Pneumatic Pressure Connections	80
Figure 18	DPS501 Altitude Reference.....	82
Figure 19	DPS500 Altitude Reference.....	82
Figure 20	DPS500/501 Fault Finding Chart	107
Table 1	DPS500 AC Power Connector Pin-Out	72
Table 2	DPS500 DC Power Connector Pin-Out	73
Table 3	WARNING MESSAGES	103-104
Table 4	DPS500/501 Fault Finding Table.....	107

This page intentionally left blank.



DPS500/DPS501 INSTRUCTION MANUAL

INTRODUCTION

1. PUBLICATION BREAKDOWN

This user instruction manual establishes the standards of operation for the DPS500 Flightline Digital Air Data test set and the DPS501 Dual Channel Controller.

Its purpose is to provide sufficient information for the personnel unfamiliar with this unit to understand it, identify its parts, and operate it in accordance with proper procedures, operating techniques, precautions and limitations.

2. INFORMATION PROVIDED WITH THE UNIT

Besides this User Instruction Manual, the Tester is delivered with the three information items described below.

- A. The Owner's Warranty Registration card (Figure 1), is to be completed by the owner and returned to Barfield, Inc. within **ten (10) days** of purchase to ensure automatic update of printed matter and validation of warranty.

OWNER WARRANTY REGISTRATION

RETURNING THIS CARD COMPLETED ENABLES US TO KEEP YOU
AUTOMATICALLY INFORMED OF TECHNICAL UPDATES and VALIDATES YOUR WARRANTY.

NAME _____ TITLE _____
 DEPARTMENT _____
 COMPANY _____
 ADDRESS _____
 CITY _____ STATE _____ ZIP _____
 P/N _____ S/N _____ MODEL # _____
 PURCHASED FROM _____ DATE _____
 AIRLINE REPAIR STATION OEM
 OTHER _____

INFORMATION GIVEN ON THIS BARFIELD, INC. WARRANTY CARD IS AND WILL REMAIN
STRICTLY CONFIDENTIAL AND WILL NOT BE SHARED. OW-28 REV / 04.00

Figure 1 Owner Warranty Registration Card

DPS500/DPS501 INSTRUCTION MANUAL

- B. The Limited Warranty Statement Card, (Figure 2), which lists the manufacturer's obligation to the original purchaser.

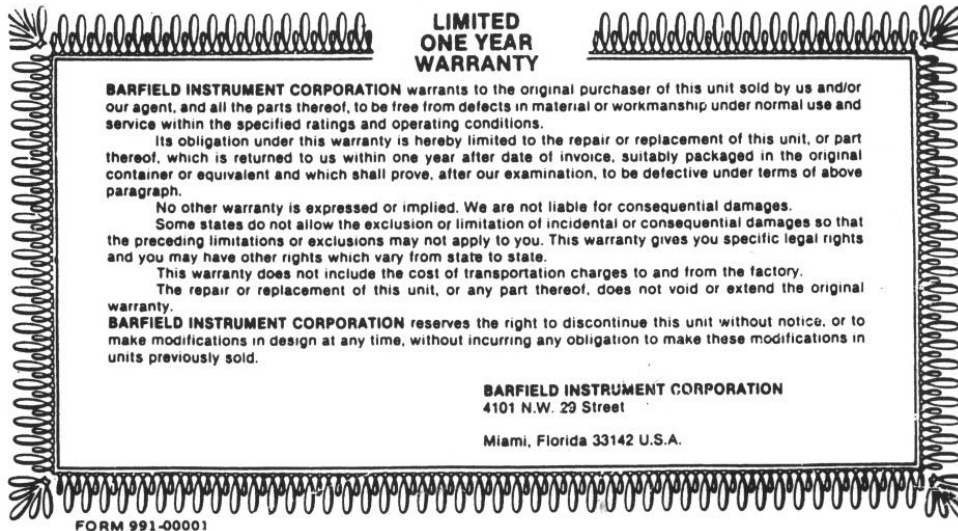

Figure 2 Limited Warranty Statement Card

- C. Each new or re-certified unit is delivered with a Certificate that shows the date when the unit was tested by the manufacturer, its serial number, and when the next certification is due. This certificate confirms that the unit performed according to its design specifications.

3. RECERTIFICATION

The DPS500 Flightline Air Data Tester and the DPS501 Dual Channel Controller utilize highly stable transducers (0.01% of range per year) qualifying them for a one year recertification cycle.

CAUTION: Maintenance required by this unit must be performed by qualified technicians in a shop equipped with very high accuracy pressure transfer standards and other necessary tooling and facilities. Calibration using an unauthorized pressure standard may affect the unit's accuracy and its capacity for testing Reduced Vertical Separation Minimum (RVSM) aircraft.

CHAPTER 1: TEST SETS DESCRIPTION

1. OUTLINE AND PURPOSE OF THE TEST SETS

The Barfield line of Automated Digital Air Data Testers comes in two versions. The DPS500 Flightline Digital Air Data Test Set (Fig. 3, page. 4) and the DPS501 Dual Channel Controller (Fig. 4, page 6). The DPS500/501 testers were developed to meet the aviation industry increasing standards such as those currently being recommended by the FAA for Reduced Vertical Separation Minimum (RVSM) certified aircraft traveling across the North Atlantic and the also need for reducing maintenance costs.

The DPS501 is a compact, 19" rack mounting unit, suitable for ATE system integration, leak testing, pressure calibration and functional testing of air data instruments, components and systems. Pneumatic connections are available via either the front or rear panel to suit specific applications. Based on digital transducer technology it requires re-certification every 12 months. Standard ranges include 850 knots airspeed, up to 15,000 ft/min. VSI, -3,000 to 105,00 ft altitude and 0 to Mach 6.5.

The DPS500 Air Data Test Set (ADTS) is a self-contained, transportable, fully automated, user programmable Pitot-Static tester housed in a military styled enclosure. A DPS500 consists of a DPS501 Dual Channel Controller, Flightline Case, Remote Hand Terminal, Electric Pressure/Vacuum Pump and other accessories. The remote hand-terminal/display permits convenient operation from the cockpit.

The DPS500/501 testers are fully automated and capable of providing simulation and precision calibration of air data indicators located on the flightline or in a certified repair shop. All functions of the tester are fully automatic and require no manual sequencing of valves or regulators. The DPS500 Flightline unit is user friendly and incorporates a remote hand terminal. The DPS500/501 also guards the aircraft system against user error and sudden leaks in the aircraft system. The DPS500/501 Test Sets meets or exceeds the demanding RVSM accuracy requirement of ± 0.0030 inHg and compliance requirements of DOT Advisory Circular 43-203B, but it is important that the customer be sure that the use of the test set will be in compliance with other aspects of the regulations. This test set also fully meets the requirements for performing FAR 43 Appendix E, Altimeter System Test and Inspections and FAR 91.411 Altimeter System and Altitude Reporting Equipment Test and Inspections.

DPS500/DPS501 INSTRUCTION MANUAL

2. PARTS IDENTIFICATION

A. DPS500 FLIGHTLINE AIR DATA TEST SET (Fig. 3).

- | | |
|-------------------------------------|--|
| (1) CASE | Bright yellow ruggedized and environmentally sealed military style case. |
| (2) DPS501 DUAL CHANNEL CONTROLLER | Dual channel controller provides automated Air Data / Pitot Static system simulation. |
| (3) PRESSURE / VACUUM PUMP ASSEMBLY | High output pressure and vacuum pump capable of 650 Knots and 80K Ft. at up to 15K Ft/min vertical speed into large volumes. |
| (4) REMOTE HAND TERMINAL | Provides control of the DPS500 flightline unit from a remote location such as the flight deck. The remote hand terminal provides full control of all test set capabilities and features with the exception of controller and pump power. (Hand Terminal is optional for the DPS501 Dual Channel Controller). |
| (5) HAND TERMINAL LEAD ASSEMBLY. | 6 ft. and 60 ft. remote leads are provided with each DPS500. Options include 100 ft or 150 ft length cables capable of reaching very large aircraft flight decks. |

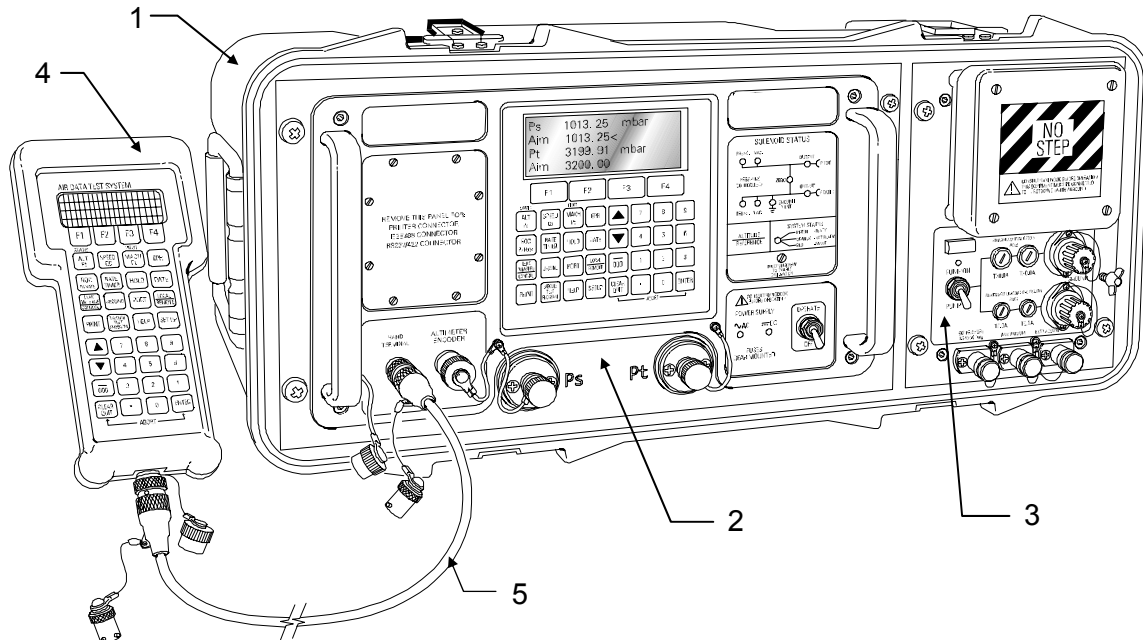

Figure 3 DPS500 Automated Flightline Air Data Test Set

DPS500/DPS501 INSTRUCTION MANUAL

B. DPS501 DUAL CHANNEL CONTROLLER (Fig. 4).

- | | |
|---|--|
| (1) POWER SWITCH | Applies power to the controller (DPS501). The pressure / vacuum pump in the DPS500 utilizes a separate power switch. |
| (2) POWER SUPPLY STATUS | Shows presence of AC or optional DC input power. |
| (3) PITOT PORT (Pt) | Connects the aircraft pitot system to the tester. (Pressure fitting MS33656-4). |
| (4) LOCAL KEYPAD | Provides the interface to select and change the Air Data / Pitot-Static functions. The Local Keypad is disabled while the Remote Hand terminal is connected. |
| (5) STATIC PORT (Ps) | Connects the aircraft static system to the tester. (Pressure fitting MS33656-6). |
| (6) ALTITUDE ENCODER / BUS MONITOR CONNECTION | Connector for interfacing the test set to an Altitude Encoder (optional) or ARINC 429 bus (optional). |
| (7) REMOTE HAND TERMINAL CONNECTION | Connector for the remote handheld terminal and optional Test Program Manager (TPM). The Local Keypad is disabled while the Remote Hand terminal or computer using the TPM is connected. |
| (8) COVER PLATE | Environmentally sealed plate covers the standard / optional IEEE and Centronix printer connectors. |
| (9) LOCAL DISPLAY | Displays pressure and rate values of the user selected Air Data / Pitot-Static parameters. The display also shows the operational menus when setting up the unit. The display fields may be changed so one, two, or three parameters are shown concurrently. |
| (10) FUNCTION KEYPAD | Selection keys for menu options available during Setup or Configuration of the DPS500 / 501. |
| (11) SOLENOID STATUS | Provides a visual representation of the controllers valve status. An illuminated LED represents an open valve and an extinguished LED represents closed. |
| (12) ALTITUDE REFERENCE | A line representing the location of the transducers contained in the test set while it is vertical. This reference level is used as a reference to set the altitude correction feature of the unit. |

DPS500/DPS501 INSTRUCTION MANUAL

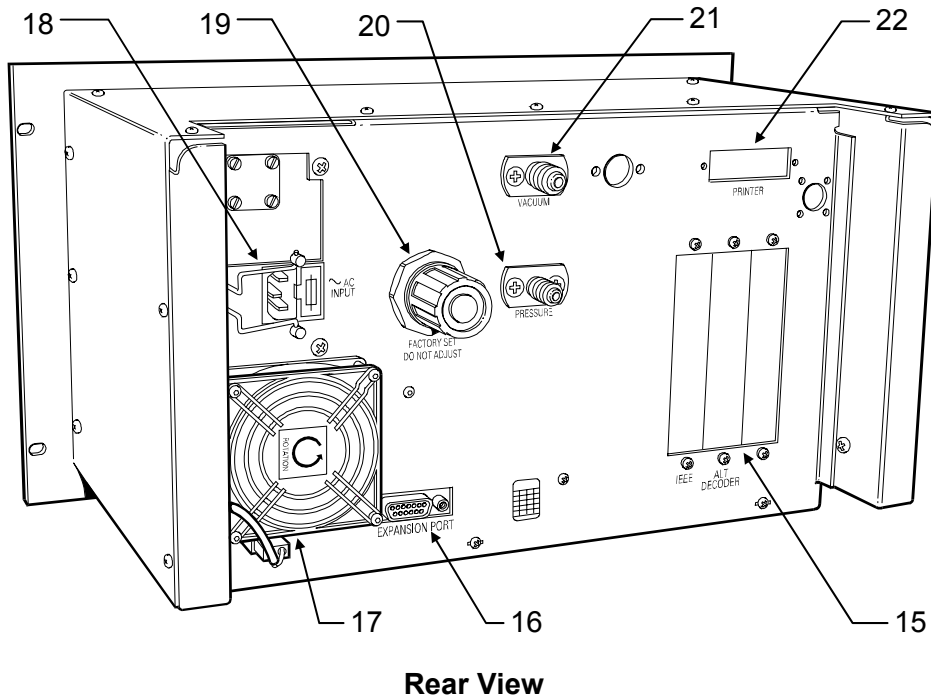
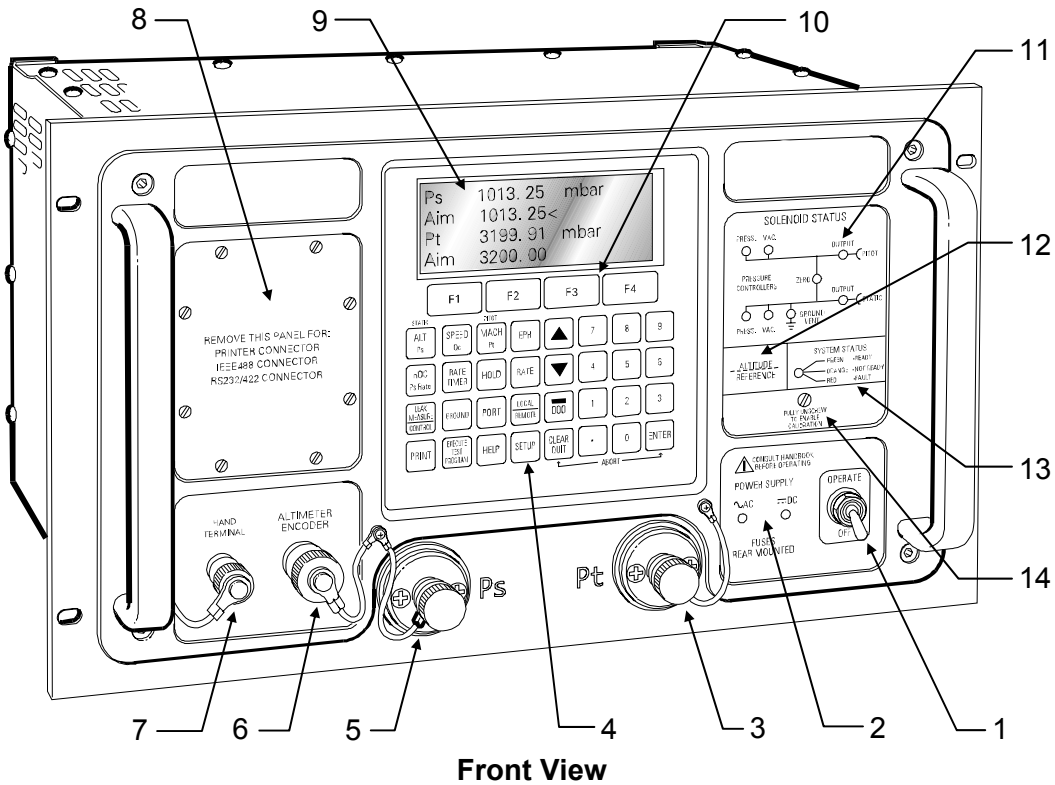

Figure 4 Two views of the DPS501 Automated Dual Channel Controller

DPS500/DPS501 INSTRUCTION MANUAL

- | | |
|--|---|
| (13) SYSTEM STATUS | Shows the status of the DPS500/ 501 during power up or fault conditions. |
| (14) CAL. ENABLE SCREW | Fully clockwise disables Calibration Mode (normal operation). Fully counterclockwise enables Calibration Mode. |
| <p style="margin-left: 40px;"><u>Note:</u> Breaking the seal over the Calibration Enable Screw may void the current test set calibration.</p> | |
| (15) OPTIONAL CONNECTORS | Provides a rear interface access to the IEEE 488 or Altitude Encoder options. |
| (16) EXPANSION PORT | Provides an interface between the DPS501 and DPS500 Pump assembly to control the dual speed pump. |
| <p style="margin-left: 40px;"><u>Note:</u> When the DPS501 is <u>not</u> used as the controller for the DPS500 Flightline unit, a jumper plug must be installed at (16) to operate the DPS501.</p> | |
| (17) COOLING FAN | Provides cooling air for electronic components. |
| (18) POWER INPUT | Provides external AC power to the DPS501. When the DPS501 is used as the controller for the DPS500 flightline unit, then power is routed through the pump assembly to the controller. |
| (19) PRESSURE REGULATOR
(Pre-set) | Internal pressure regulator. Factory pre-set, do not adjust. |
| (20) PRESSURE INPUT (Pt) | Connects the external pressure source to the DPS501. When the DPS501 is used as the controller for the DPS500 Flightline unit, the pump assembly serves as the pressure source. |
| (21) VACUUM INPUT (Ps) | Connects the external vacuum source to the DPS501. When the DPS501 is used as the controller for the DPS500 Flightline unit, the pump assembly serves as the vacuum source. |
| (22) PRINTER CONNECTION
(if rear mounted) | Provides a rear mounted interface to connect an external printer. |

DPS500/DPS501 INSTRUCTION MANUAL

C. REMOTE HANDHELD TERMINAL (Fig. 5).

- | | |
|---------------------|--|
| (1) REMOTE DISPLAY | Displays pressure and rate values of the user selected Air Data / Pitot-Static parameters. The display also shows the operational menus when setting up the unit. The display fields may be changed so one, two, or three parameters are shown concurrently. |
| (2) FUNCTION KEYPAD | Selection keys for menu options available during Setup or Configuration of the DPS500/501. |
| (3) REMOTE KEYPAD | Provides the interface to select and change the Air Data / Pitot-Static functions. The Local Keypad is disabled while the Remote Hand terminal is connected. |

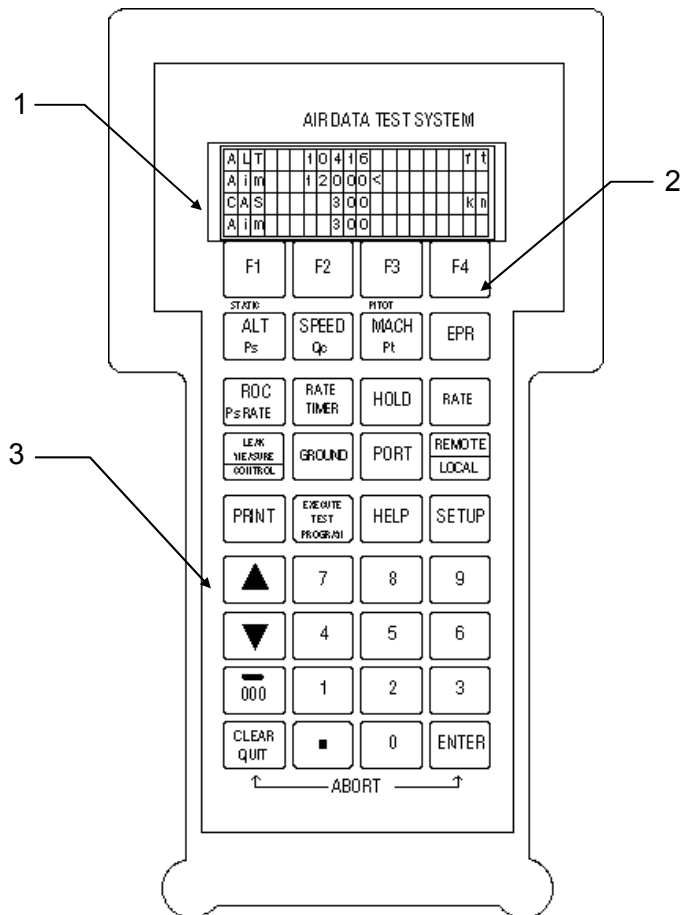

Figure 5 DPS500/501 Remote Handheld Terminal

DPS500/DPS501 INSTRUCTION MANUAL

D. PRESSURE/VACUUM PUMP (Fig. 6).

Note: The AC configuration shown here, differs from the AC/DC arrangement of Fig 3.

- | | | |
|-----|-----------------------------|---|
| (1) | FAN COVER | Protects the pumps cooling fan. |
| (2) | HOUR METER | Displays the total hours of operation of the pump. |
| (3) | POWER SWITCH | Applies power to the pump assembly (DPS500).
The DPS501 in the DPS500 uses its own switch. |
| (4) | EXTERNAL PRESSURE CONNECTOR | Allows operation using an external pressure source.
(Pressure fitting MS33656-4). |
| (5) | AUXILIARY VACUUM | Provides a source of vacuum for static port suction fittings or Leach adapters. |
| (6) | FUSES | Provides AC and DC input power protection. |
| (7) | POWER CONNECTOR | Input jack for external AC and optionally DC power. |
| (8) | EXTERNAL VACUUM CONNECTOR | Allows operation using an external vacuum source.
(Pressure fitting MS33656-6). |

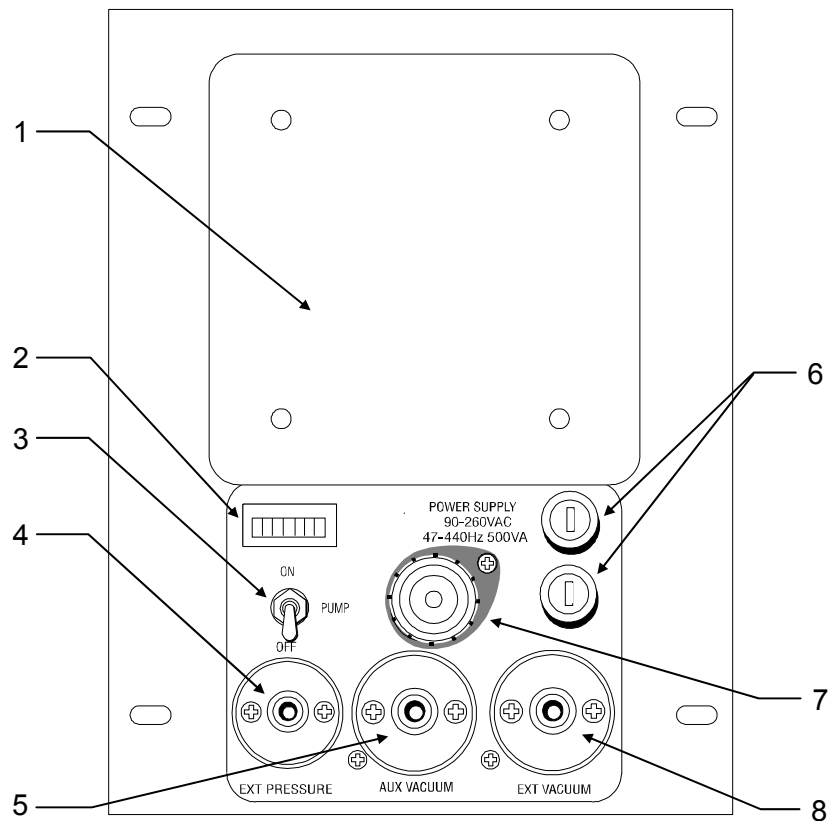

Figure 6 DPS500 Pressure/Vacuum Pump Assembly



DPS500/DPS501 INSTRUCTION MANUAL

3. DPS500/501 FEATURES DESCRIPTION

A. FULLY AUTOMATED

The operation of the unit is totally controlled by a microprocessor. The user, who does not have access to operate any of its valves, simply enters, using a keypad, the parameters of a test point, and the Test Set regulates itself to reach it quickly and safely.

B. REMOTE HAND TERMINAL

Due to the crowded conditions typically found on an aircraft, a remote hand terminal was necessary to provide complete control of the tester without crowding the flight deck with test equipment. An additional benefit of having a remote hand terminal is a reduction in maintenance costs due to needing only a single maintenance person to conduct the aircraft test and calibration. The remote provides full control of the tester with the exception of controller and pump power. The DPS500 comes with a 2 Meter and 18 Meter remote extensions. Optional 100 foot and 150 foot remote extensions are also available.

C. PROGRAMMABLE CONTROLLED RATES (VERTICAL SPEED, AIRSPEED, ETC.)

The DPS500/501 operates in both aeronautical rates and pressure rates, e.g. Ft/Min and inHg. The Vertical Speed (Ft/Min), Airspeed (Kts/Min), and other rates such as inHg are set via the keyboard and are maintained during pressure changes. The controller maintains Ps & Qc to $\pm 1\%$, Pt to $\pm 2\%$, and Airspeed to $\pm 5\%$ of the desired rate.

Example: The Rate of Climb (ROC) is set at 6000 Ft/Min and the Altitude test point is set to 10,000 Ft. The altitude will climb at a rate of approximately 6000 Ft/Min until 10,000 Ft is achieved.

D. HIGH RANGE AIRSPEED (OPTION)

High range airspeed up to 1000 knots is available for Military applications.

E. PRINT OUT CAPABILITY.

The DPS500 contains a print facility to print the displayed readings together with up to nine user readings (e.g. Pilot, Co-pilot, Aux.).

This facility will work with any Centronics standard parallel interface printer of 80 or 132 column width.

DPS500/DPS501 INSTRUCTION MANUAL

F. IEEE 488 FOR 1975 SYSTEM COMPATIBILITY OR SCPI PROTOCOL (OPTIONS)

IEEE 488 is an interface developed for establishing a communication command path between Automatic Test Equipment (ATE) components. The communication between the ATE and the IEEE 488 interface consists of data and memory addresses. The 1975 System compatibility is equivalent to Sperry/Honeywell 222 Compatibility.

G. TWO AIRSPEED DISPLAYS: CALIBRATED (INDICATED) OR CALCULATED (TRUE)

The DPS500 / 501 default airspeed display is Indicated Airspeed (IAS). Changing the display to True Airspeed (TAS) and an input of the ambient temperature allows the DPS500/501 to calculate and display True Airspeed.

H. AUTO LEAK PROTECTION

The Autoleak recovery feature is designed to automatically intervene if a leak exceeding 3000 Ft/Min. or 300 Kn./Min. is detected while the tester is in the Leak Measure Mode.

CAUTION: THE AUTO LEAK FEATURE SHOULD ALWAYS BE ON DURING AIRCRAFT TESTING. THE AUTO LEAK FEATURE BEING OFF DURING AN AIRCRAFT TEST COULD RESULT IN DAMAGE TO KEY AIRCRAFT PITOT-STATIC COMPONENTS.

I. AUTO LIMIT PROTECTION

Auto Limit insures that the aircraft limits are maintained even while leak checking the aircraft at or near the limits selected. For example, an airspeed leak test at 650 knots where the limit is set at 650 knots. If the differential pressure changes during the leak test causing airspeed to exceed the programmed limit, the Auto Limit feature will automatically return the DPS500 to Control Mode and stabilize the pressures.

J. AIRCRAFT LIMITS DATA BASE

User error is eliminated by checking all data input by a technician against the user programmed maximum and minimum default limits. When a tester is used for servicing numerous types of aircraft, the user can program and store unique aircraft limits and specifications in the testers memory. These user programmed limits and specifications can then be recalled from memory by a technician while leak testing or calibrating an aircraft air data system.

K. INTERNAL SOLENOID STATUS

An abbreviated plumbing diagram is displayed on the front panel containing LED's which illuminate when valves are open. This is a beneficial tool which shows the status of the tester valves during testing.



DPS500/DPS501 INSTRUCTION MANUAL

L. GO TO GROUND

A feature which safely depressurizes the aircraft and tester to ambient pressure when testing is complete.

M. PACKAGED IN MILITARY-STYLE ENCLOSURE WITH WHEELS.

Tester is enclosed in a rugged military style box equipped with wheels on one end which aids in carting the unit to a distant location such as the flightline.

N. TEST PROGRAM MANAGER (TPM) OPTION.

The TPM includes the software and hardware needed to interface the DPS500/501 with a personal computer. The TPM allows programming of procedures necessary for carrying out instrument and aircraft tests such as FAR 43 or RVSM. These user-programmed tests are created in a PC based text editor using very simple commands. The test data is tabulated and can be printed for use in QC reports or instrument calibration records. The programs may also be downloaded into the DPS500 for running test routines without the need for a PC.

4. CONTROLS

Note: The List of Controls included in this section, is sorted according to their positions in the Remote Keyboard (Fig. 7), from left to right and from top to bottom.

F1 - F4 FUNCTION KEYS

Function Keys used in conjunction with the DPS500/501 menus.

ALT / Ps

In aeronautical units (ft or m), this key will select an altitude display.

In pressure units (mbar, inHg etc.), this key will select a static pressure (Ps) display.

SPEED / Qc

In aeronautical units (knots., km/h), this key will select an airspeed (CAS or TAS) display. In pressure units (mbar, inHg etc.), this key will select a dynamic pressure (Qc) display.

The airspeed can be displayed and entered as either Calibrated Airspeed (CAS, Vc) or True Airspeed (TAS, Vt). Calibrated Airspeed is equivalent to Indicated Airspeed (IAS) for testing purposes.

TAS depends on Pt temperature. This should be set to the local temperature. Information on TAS and Temperature SETUP can be found on page 40.

DPS500/DPS501 INSTRUCTION MANUAL

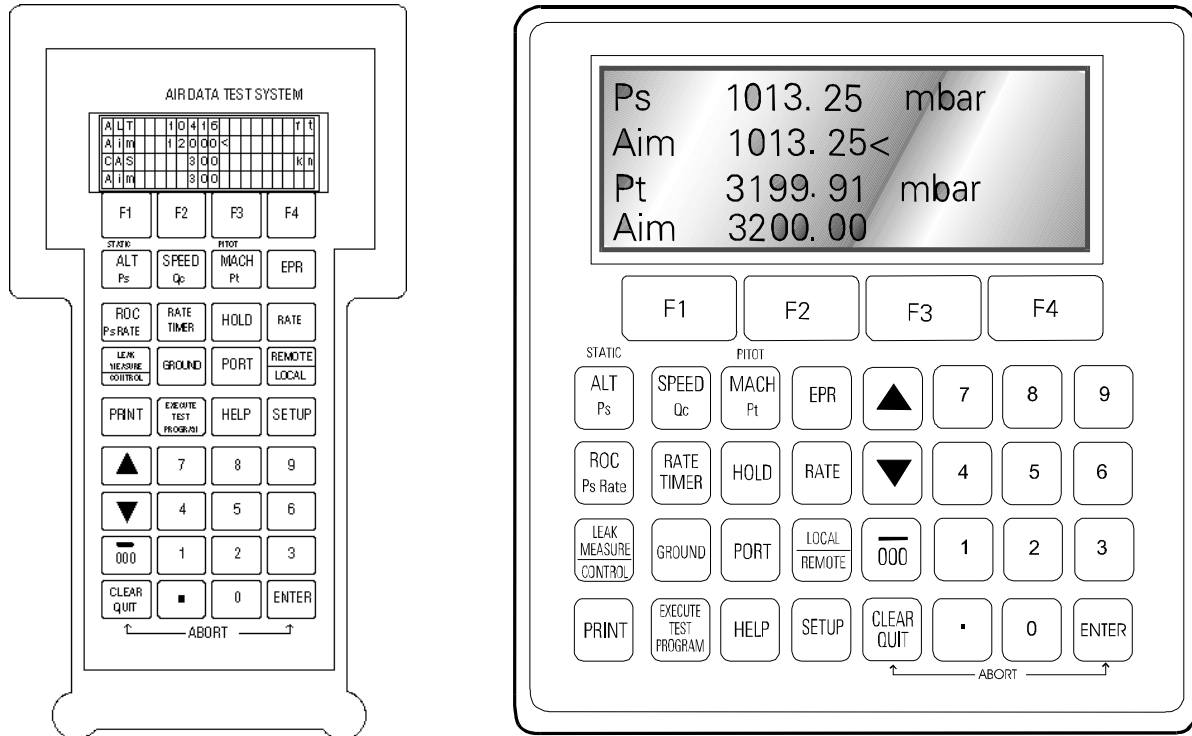

Figure 7 Remote and Local Keyboards

MACH / Pt

In aeronautical units (ft/kn. or m/Km/h), this key will select a Mach display.

In pressure units (mbar, inHg etc.), this will select a Total Pressure (Pt) display.

If the altitude aim is changed, CAS will change to maintain the Mach.

Note: “Aim” is the word displayed in the screen and used through this Manual, to indicate the desired target value of a parameter, either in pressure or aeronautical units.

EPR

Engine Pressure Ratio (EPR) is only available in pressure units (mbar, inHg etc.).

The ADTS may be used to check EPR transducers and gauges.

ROC / Ps RATE

In aeronautical units (ft or m), this key will select a Rate of Climb (ROC) display, also known as vertical speed.

In pressure system units (mbar, inHg etc.), this key will select a rate of change of Ps display.

DPS500/DPS501 INSTRUCTION MANUAL

RATE TIMER

The RATE TIMER key starts an internal timer for one of three selected time periods. At its completion, the average rate of change over the time period is displayed.

Each selected TIME period can have an associated WAIT period to allow pressures to settle before timing starts. The WAIT period counts down to zero before the TIME period starts.

HOLD

When HOLD is pressed, a ramping pressure will hold exactly where it is. Pressing HOLD again releases the pressure to continue to the aim value. Hold applies to both channels simultaneously.

RATE

In aeronautical units (kn., km/h), this key will select a rate of change of airspeed (Rate CAS) display.

In pressure units (mbar, inHg etc.), this key will select a rate of change of pressure (Rate Qc, Rate Pt or Rate EPR) display. The actual display depends on the parameter selected before pressing RATE.

The following rates are available in aeronautical units:

KEY-PRESS SEQUENCE	RATE OF CHANGE DISPLAY
SPEED, RATE	Rate CAS *
MACH, RATE	Not valid

* Rate CAS will be displayed whether airspeed is in CAS or TAS.

The following rates are available in pressure units:

KEY-PRESS SEQUENCE	RATE OF CHANGE DISPLAY
Qc, RATE	Rate Qc
Pt, RATE	Rate Pt
EPR, RATE	Rate EPR

LEAK MEASURE / CONTROL

This key toggles the pressure controllers on or off.

The controllers can be switched off to measure leaks in the aircraft system.

The display shows "LEAK MEASURE" when the controllers are off.

DPS500/DPS501 INSTRUCTION MANUAL

GROUND

This key enables a display of ground pressure or automatically takes the pressures in the aircraft system to local atmospheric pressure in a controlled manner.

The local atmospheric pressure is recorded by the ADTS during the power-up sequence.

When GROUND is pressed, a menu gives a choice of three ground functions:

(1) [GO TO GROUND]

Selecting [GO TO GROUND] automatically enters an altitude or static aim equivalent to local atmospheric pressure. It also enters an airspeed or dynamic pressure aim of zero. The system pressures will then move towards these aims in the normal way, at the rates set by the ROC and RATE keys. At any time while going to ground, a new rate of change can be entered. The ADTS will continue going to ground.

At any time while going to ground, a new value aim for Alt, CAS, TAS Mach, Ps, Qc, Pt or EPR can be entered. In this case, the ADTS will no longer be going to ground. Operation will then proceed as normal.

(2) [DISPLAY QFE]

When [DISPLAY QFE] is selected (QFE: radiotelegraph code for *atmospheric pressure at airfield elevation*), a stored local atmospheric pressure is displayed. This pressure value is initially stored in memory during test set initialization (power up) and then updated upon completion of a GO TO GROUND function.

Press QUIT to return to the normal user display.

(3) [DISPLAY QNH]

When [DISPLAY QNH] is selected (QNH: radiotelegraph code for *atmospheric pressure at sea level*), the local atmospheric pressure recorded during power-up or upon completion of a GO TO GROUND function is converted to the equivalent sea level pressure and displayed as QNH together with the station altitude.

Note: The station altitude can be changed using SETUP, GROUND.

PORT

The PORT facility is not available on either the DPS500 or DPS501 Test Sets.

REMOTE / LOCAL

The REMOTE / LOCAL facility is used on DPS Test Sets having the IEEE 488 option.

PRINT

The DPS500 contains a print facility to print the displayed readings together with up to nine user readings (e.g. Pilot, Co-pilot, Aux.).

This facility will work with any standard parallel interface printer.

DPS500/DPS501 INSTRUCTION MANUAL

EXECUTE TEST PROGRAM

Allows execution of user programmed test scenarios downloaded into the testers memory using the Test Program Manager option.

The Test Program Manager (TPM) Option is required for programming and downloading of the executable test routines.

HELP

The HELP key provides help on each key. The help message generally gives associated functions and ways of changing the way the key works.

Inside the user display, the user can get help on any of the keys on the keypad by pressing HELP, then pressing the desired key to get help information about it. Some help screens show MORE over the F4 key. In this case, press F4 to view a further help screen.

Press QUIT to exit the help system.

SETUP

- (1) SETUP allows access to secondary functions that do not have a key assigned to them.
- (2) Any parameters changed under SETUP will revert to the default settings on power-down.
- (3) The CONFIGuration mode may be used to change the default settings so that the ADTS powers up in the required state. See information starting on page 49 for CONFIGuration details. Almost all SETUP parameters are also available under CONFIG. In addition, some parameters are only available under CONFIG.

Certain parameters under SETUP can be locked from CONFIG so the user cannot inadvertently change them. An example of this would be aircraft limits where the ADTS can be made to power-up with a particular set of limits that cannot be changed. If the user tries to change a parameter that is locked, a warning is given.

CLEAR / QUIT

- (1) When menus are displayed, CLEAR / QUIT is used to escape to the previous menu.
- (2) During numeric entry, CLEAR / QUIT removes the new number and restores the previously entered number.
Note: Once the ENTER key has been pressed, the old number cannot be restored.
- (3) For those displays containing a SAVE option, changes made before pressing CLEAR / QUIT are ignored. For all other displays, changes are saved when CLEAR / QUIT is pressed.
- (4) When warning messages are displayed, press CLEAR/QUIT to remove the message.

DPS500/DPS501 INSTRUCTION MANUAL

0 to 9 KEYS

- (1) Used for numeric entry. Press ENTER to complete numeric entry. Press CLEAR / QUIT if a mistake is made during numeric entry.
- (2) All data entry is based on over-writing the existing value. When the first numeric key is pressed, the existing number is replaced by the key pressed. At any time, the existing number may be recovered by pressing the CLEAR / QUIT key.

- / 000 KEY

This key performs two functions during numeric entry:

- (1) If it is pressed before a number, it places a minus sign for entry of negative values.
- (2) If it is pressed after a number, it adds three zeros for fast entry of thousands.

NUDGE UP (▲) / NUDGE DOWN (▼)

- (1) This facility increments AIM values UP or Down by a specific value. The increment value can be set through the SETUP function described on page 47.
- (2) This facility can be used to align pointers to the cardinal points on the instruments. It is more accurate to do this and read the value off the DPS500 / 501 display than to estimate the instrument reading with a pointer not on the cardinal point.
- (3) This facility is used for Mach overspeed tests or pressure switch testing, as follows:
 - (a) Aim for an Airspeed or pressure just below the expected operating point.
 - (b) When the Airspeed or pressure is achieved, repeatedly press Nudge Up (▲) until the switch operates.
 - (c) Record the Airspeed or pressure reading shown on the display.
- (4) Holding down the NUDGE key automatically repeats the function.
- (5) The nudge value can be used for large increments e.g. 100 kts. or 5000 ft to “step through” cardinal test points on tests such as FAR 91-411.

ENTER

The ENTER key completes numeric entries

CLEAR / QUIT + ENTER (ABORT)

- (1) When CLEAR/QUIT and ENTER keys are pressed simultaneously, the DPS500/501 restarts from the power-up sequence.
- (2) When the keys are pressed all output values immediately close.
- (3) The ABORT function should only be used as a last resort:
 - (a) When a restart is required after the system has shutdown displaying an error message.
 - (b) As an emergency measure.

This page intentionally left blank.

CHAPTER 2 SPECIFICATIONS AND CAPABILITIES

1. PHYSICAL DATA

	DPS500	DPS501
A. Height	13.0 in. (33 cm)	10.5 in. (26.7 cm)
B. Width	30.0 in. (76.2 cm)	19.0 in. (48.3 cm)
C. Depth	17.5 in. (44.5 cm)	10.0 in. (25.4 cm)
D. Weight	63.8 lb. (28.9 kg)	26.5 lb. (12 kg)

2. SPECIFICATIONS

A. Altitude Range:	-3,000 to 105,000 Ft. (Pump capable of 80,000 Ft.)
B. Airspeed Range:	20 to 850 knots 20 to 1000 knots (Special High Range Airspeed Option)
C. Rate of climb:	0 to \pm 15,000 Ft/min. into large volumes.
D. Mach Range:	0.16 to 6.5
E. Ps channel Range:	0.1 to 40 inHg absolute (Static port)
F. Pt channel Range:	0.3 to 80 inHg absolute (Pitot port) 0.1 to 103.3 inHg (Special High Range Airspeed Option) absolute (Pitot port)
G. Qc channel Range:	-39.9 to 50.2 inHg differential -39.9 to 73.8 inHg (Special High Range Airspeed Option) differential
H. EPR Range:	1 to 10



DPS500/DPS501 INSTRUCTION MANUAL

3. ACCURACY (typical)

The following accuracy specifications of the DPS500 can be achieved after a 15 minute warm-up period and includes curve fit errors, temperature effects, hysteresis and repeatability.

- A. Altitude: ± 0.0015 inHg rising to ± 0.0030 inHg
 - ± 3 Ft. at sea level
 - ± 4 Ft. at 10,000 Ft.
 - ± 5 Ft. at 20,000 Ft.
 - ± 7 Ft. at 30,000 Ft.
 - ± 10 Ft. at 40,000 Ft.
 - ± 16 Ft. at 50,000 Ft.
 - ± 25 Ft. at 60,000 Ft.

- B. Airspeed: ± 0.0030 inHg rising to ± 0.008 inHg
 - ± 2.1 Kts. at 23 Kts.
 - ± 1.0 Kts. at 50 Kts.
 - ± 0.5 Kts. at 100 Kts.
 - ± 0.3 Kts. at 200 Kts.
 - ± 0.1 Kts. at 500 Kts.
 - ± 0.1 Kts. at 650 Kts.

- C. Rate of Climb: $\pm 1\%$ of value

- D. Mach: ± 0.005 mach

- E. EPR: ± 1 count of display

4. REPEATABILITY

Repeatability is defined as the change or variation in reading when the same pressure is re-applied after an excursion between minimum and maximum of range (this is, including HYSTERESIS). The repeatability does not include curve fit errors.

- A. Ps channel: ± 0.0015 inHg

- B. Pt channel: ± 0.0015 inHg rising to ± 0.005 inHg

DPS500/DPS501 INSTRUCTION MANUAL

5. CONTROLLER PERFORMANCE

A. STABILITY

The DPS500 provides stable pressure values at the outlet ports and continues to control smoothly without oscillation into volumes up to 1,000 cubic inches (17 liters) on Ps and a volume of up to 600 cubic inches (10 liters) on Pt at rates up to 6000 Ft/min. Lower volumes allow for higher rates to be achieved.

The following Table shows the figures based on a 40 ppm FS of Ps or Qc full scale over a bandwidth of 0.1 to 1.5 Hz and using RMS values. The two Qc ranges used by the DPS500 are indicated.

CHANNEL		CONTROLLER STABILITY
Ps	1,355 mbar	± 0.038 mbar
	40 inHg	± 0.0011 inHg
Qc	1,700 mbar	± 0.045 mbar
	50 inHg	± 0.0014 inHg
Qc	2,500 mbar	± 0.070 mbar
	74 inHg	± 0.0021 inHg

B. RATE CONTROL

The DPS500 operates in both aeronautical rates and pressure rates, e.g. ft/min. and inHg/min. Rate control is provided for the Ps, Pt and Qc parameters in either aeronautical or pressure units. The following are possible:

- Ps - ft/min. or meters/min. - max. rate 100,000 ft/min.
- absolute pressure units/min.
- Pt - absolute pressure units/min.
- Qc - kts/min. or km/h/min. - max. rate 2,000 kts/min.
- differential pressure units / min.

A rate of 20,000 ft/min. into 10 liters (600 cubic inches) on Ps and 6.7 liters (400 cubic inches) on Pt with single vacuum pump operation is achievable.

C. CONTROL RESPONSE

The desired operating pressure value will be achieved without any overshoot independent of the system volume on either Ps or Pt channels. The system response to input commands takes place within a 400 ms period.



DPS500/DPS501 INSTRUCTION MANUAL

D. DYNAMIC TESTING / OSCILLATOR

The DPS500 can generate sinusoidal variations of either the Ps or Pt or both channels. Frequency and amplitude of the desired oscillation is keypad programmable; external volume naturally limits the achieved results. Maximum drift from the mean value during dynamic testing will be no worse than twice that specified for steady state testing.

E. CONTROL OFFSET

The displayed value will be within the control stability values for the appropriate channel.

6. RATE CONTROL PRECISION:

Ps and Qc rate control will be within a $\pm 1\%$ of desired value within 5 seconds of the entry being made on the keypad. Pt rate will be within $\pm 2\%$ of desired value. The rate accuracy is defined as the change averaged over a one minute measurement period. Rate timing is provided to determine exact values of parameter changed. Airspeed accuracy will be within $\pm 5\%$ of desired value.

7. TEMPERATURE RANGES:

Temperature specifications for the DPS500/501 are as follows:

Calibrated..... + 5 to + 35° C.
Operating -10 to + 50° C
Storage..... - 40 to + 70° C

8. DISPLAY UNITS:

- A. Airspeed: Knots, km/hr
- B. Altitude: Feet, meters
- C. Mach: Mach
- D. Rate of Climb: Feet/min, Meters/min
- E. Rate of Airspeed: Knots/min
- F. EPR: Ratio (Pt / Ps), Pt & Ps: inHg, mbar, psi
- G. Other: inHg, mmHg, inH₂O (at 4° C), inH₂O (at 20° C), inH₂O (at 60° F), psi, mbar, hPa, kPa.

DPS500/DPS501 INSTRUCTION MANUAL

9. PRESSURE MEDIA

The DPS501 Dual Channel Controller requires an external pressure and vacuum source meeting the following requirements:

The DPS501 requires only a single vacuum inlet and a single air pressure inlet. At the control set-point operating into a leak tight system, no air is consumed. A single vacuum source is adequate for the rates detailed into the volumes listed with no crosstalk between Ps and Pt channels. A pump capable of 14 liters/min. (0.39 cubic ft/min.) is required. The air pressure source should be clean dry air (Nitrogen not recommended) at a pressure of 3 to 6 bar (45 to 90 psi) with the DPS501 having an internal regulator to protect the controllers. Filtering should be better than 15 microns and a flow rate equivalent to 2.8 lt/min. (0.1 ft³/min.) at the above pressure.

The pressure / vacuum pump supplied with the DPS500 meets all of the above requirements.

10. TRANSDUCERS

Latest Technology Transducers with highest accuracy and stability commercially available.

11. INPUT POWER

Single Phase AC in the range of 88 to 260 VAC

Over the frequency of 47-440 Hz

DPS500 - 500VA

DPS501 - 200VA

Units with S/N beginning with an "A" have the following AC power connector breakdown:

PIN	EUROPEAN COLOR	US COLOR	FUNCTION
1	Brown	Black	Live
4	Blue	White	Neutral
Center	Green / Yellow	Green	Ground

DC Power (Optional), 24 - 30V. The following is the 28VDC connection breakdown:

PIN	CONNECTION
1	+ 28V
2	0V Return
GND	Ground



DPS500/DPS501 INSTRUCTION MANUAL

12. PRESSURE FITTINGS

Ps: MS33656-6
Pt: MS33656-4
Pressure supply: MS33656-4
Vacuum supply: MS33656-6

13. WARM-UP REQUIREMENTS

If the DPS500/501 temperature has stabilized within the operating temperature range before switching on, the DPS500/501 requires a nominal warm-up period of 15 minutes to achieve the stated accuracy.

14. PACKAGING LIST

A. DPS501

- (1) Rack DPS501
- (2) Power lead
- (3) Operations Manual
- (4) Output fittings (MS33656-4 x2, MS33656-6 x 2)
- (5) Spare fuses (2 ea.)
- (6) Spare Rubber "O" Rings (Input / Output Pressure Fitting)

B. DPS500

- (1) Flight line DPS500
 - (a) DPS501 Dual Channel Controller
 - (b) Heavy Duty Plastic Case with Wheels
 - (c) Pressure / Vacuum Pump Capable of 80K Ft and 850 Kts
- (2) Accessory bag
- (3) Power lead
- (4) Hand terminal
- (5) Hand terminal lead - 2 m
- (6) Hand terminal lead - 18 m
- (7) 2.5m hose - red (MS 33656-6 to open end)
- (8) 2.5m hose - blue (MS 33656-4 to open end)
- (9) Operations Manual
- (10) Spare fuses (2 ea.)
- (11) Spare Rubber "O" Rings (Input / Output Pressure Fitting)

CHAPTER 3: DPS500/501 SETUP AND CONFIGURATION

1. DPS500 / 501 SETUP

The DPS500 / 501 SETUP function allows access to secondary capabilities using a menu system, it also extends the keyboard and allows many of the DPS500 / 501 functions to be customized. These functions include but are not limited to setting the displayed units of measure, aircraft limit protection as well as allow users to customize many of the DPS500 / 501 functions to meet their own individual requirements.

All changes made under SETUP are temporary (Volatile Memory) and will be lost at power-down. Any parameters changed under SETUP will revert to the default settings the next time the DPS500/501 is powered up.

The **F1**, **F2**, **F3** & **F4** just below the DPS501 Controller and / or Remote Handheld Terminal LCD displays are function keys or soft-keys used to select choices from the setup menus. The menu choices may be displayed in the standard format selected by pressing the Function Key corresponding to the listed operation in the LCD or by pressing the Function Key directly below the desired operation, both menu types are shown below.

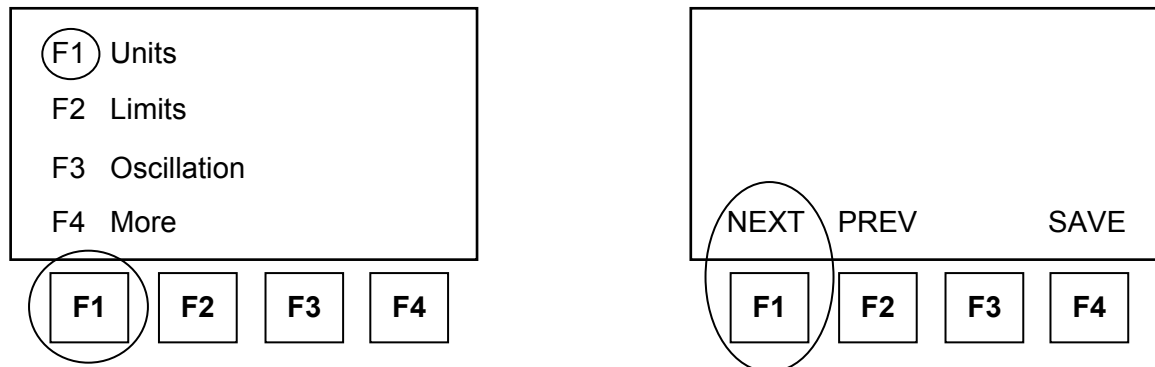

For quick reference, tree diagrams of the setup menus (page 36) and key setup (page 48) are provided at the end of the applicable section.

The SETUP key also provides access to the CONFIGuration mode described starting on page 49. CONFIG is very similar to SETUP with many identical functions. The major difference is that changes made under CONFIG are non-volatile memory and are not lost at power-down.

DPS500/DPS501 INSTRUCTION MANUAL

A. DPS500/501 MENU SETUP

To enter the SETUP Function of the DPS500/501 press the SETUP key on the middle right side of the Remote Handheld Terminal or the lower middle on the Local Key Pad. Once the SETUP key is pressed, SETUP functions are then available from both the SETUP menu and directly by pressing certain keys. Subsections (1) and (2) below describe how to select the functions accessible through the SETUP menu #1 and SETUP menu #2. For quick reference, Figure 8, page 36, shows a tree diagram of the setup menus.

1. SETUP Menu #1

Setup Menu #1 is in the standard format. When the menu is displayed, press the corresponding Function Key (**F1** displayed = **F1** key, etc) to select the desired operation or function.

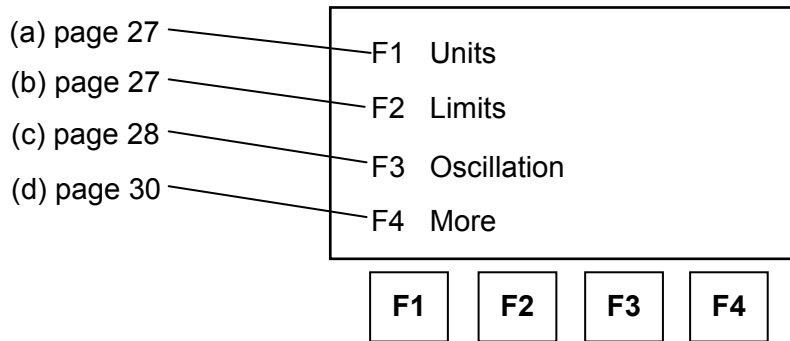

The following is an operational description of the functions accessed by using the *SETUP Key plus the corresponding Menu item listed below*: The information inside the parenthesis represents the sequence of buttons that needs to be pressed to perform the Setup function or operation.

Note: Some DPS500/501 Functions or Setup operations require the test set to be in a particular mode or displayed pressure unit to perform the operation. Example: To change the Limit Protection to a different aircraft, the Test Set must be in the “Leak Measure” Mode. This is required to protect the aircraft from potential damage.

DPS500/DPS501 INSTRUCTION MANUAL

- (a) F1 – Units: Changes the Units of Measure displayed by the DPS500 / 501 (Setup + F1).

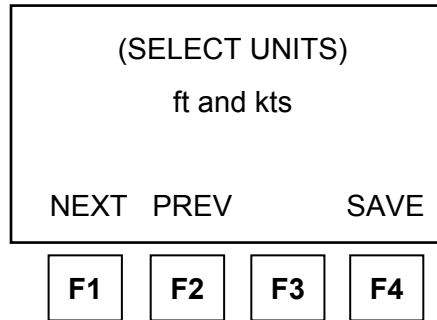

Use the F1-NEXT and F2-PREV keys to step through the available units until the display shows the desired unit. Press SAVE to select the desired unit.

Available Units:

ft and Knots	inHg	psi
ft and mph	mmHg	hPa
m and km/hr (m/min)	inH ₂ O 4°C	kPa
m and km/hr (m/s)	inH ₂ O 20°C	mbar
m and km/hr (hm/min)	inH ₂ O 60°F	

- (b) F2 – Limits: Allows Selection of User Programmed Aircraft Limits (Setup + F2).

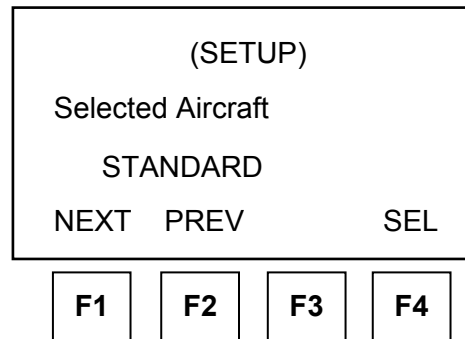

Use the F1-NEXT and F2-PREV keys to step through the user programmed Aircraft Limits (see “Limits”, page 53, for guidance on Aircraft Limits programming) until the display shows the desired aircraft. Press SEL to select among the available Aircraft Limits, which are:

CIVIL is a factory-programmed limit with the following Aeronautical Limits:

Max. Altitude = 50,000 ft	Min. Altitude = -1000 ft	Max. CAS = 450 knots
Min. CAS = 0.0 knots	Max. Mach = 1.000	Max. ROC = 6,000 ft/min
Max Rate CAS = 600 knots/min	Altitude Correction = 0 ft	

DPS500/DPS501 INSTRUCTION MANUAL

STANDARD is a factory-programmed limit with the following Aeronautical Limits:

Max. Altitude = 80,000 ft Min. Altitude = -2000 ft Max. CAS = 850 knots
 Min. CAS = 0 knots Max. Mach = 2.50 Max. ROC = 9,000 ft/min
 Max. Rate CAS = 600 knots/min Altitude Correction = 0 ft

CAUTION: DUE TO “STANDARD” HAVING HIGHER LIMITS THAN SPECIFIED FOR MOST CIVIL AIRCRAFT, THE “STANDARD” LIMITS SETTING ON THE DPS500/501 IS NOT RECOMMENDED FOR CONTINUOUS USE WHILE CONNECTED TO AN AIRCRAFT. (SEE “LIMITS”, PAGE 53, FOR GUIDANCE ON AIRCRAFT LIMITS PROGRAMMING).

MAX is a factory-programmed limit with the following Aeronautical Limits:

Max. Altitude = 105,000 ft Min. Altitude = -3000 ft Max. CAS = 850 knots
 Min. CAS = -100.0 knots Max. Mach = 12.350 Max. ROC = 100,000 ft/min
 Max. Rate CAS = 2000 knots/min Altitude Correction = 0 ft

CAUTION: DUE TO THE VERY HIGH LIMITS, THE MAX LIMITS SETTING ON THE DPS500/501 SHOULD NOT BE USED WHILE CONNECTED TO AN AIRCRAFT.

(c) F3 - Oscillator: Operation of Ps and Pt Channel Oscillator (Setup + F3).

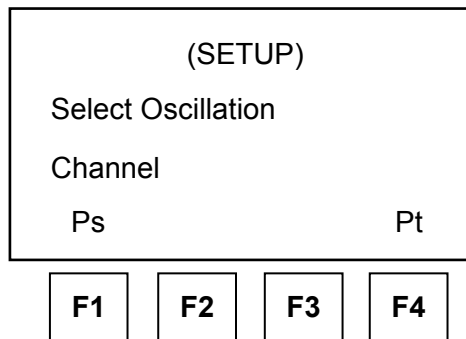

The DPS500 has an oscillation facility that causes the pressure to oscillate about an aim value (Altitude or Airspeed) at a user-defined frequency and amplitude. To access the oscillation facility:

Note: The DPS500/501 must be in the CONTROL mode for oscillation to operate.

- (i) Select SETUP
- (ii) Select F3-Oscillation

DPS500/DPS501 INSTRUCTION MANUAL

(iii) Select F1-Ps for static channel oscillation or F4-Pt for pitot channel oscillation.

F1 Start Ps Osc
F2 Stop Ps Osc
F3 Freeze Ps Osc
F4 Ps Osc Ampl/Freq

F1

F2

F3

F4

Static Channel Oscillation Menu

F1 Start Pt Osc
F2 Stop Pt Osc
F3 Freeze Pt Osc
F4 Pt Osc Ampl/Freq

F1

F2

F3

F4

Pitot Channel Oscillation Menu

Below is an operational description of the oscillator functions applicable to both the Ps and Pt channels:

- | | |
|---|---|
| F1 - Start (Ps or Pt) Osc. | – Starts the oscillation. (Amp / Freq (F4) must be setup prior to Start). |
| F2 - Stop (Ps or Pt) Osc. | – Stops the oscillation and returns to the original AIM value of the parameter. |
| F3 - Freeze (Ps or Pt) Osc. | – Stops the oscillation at the current Alt., Airspeed, Ps or Pt pressure. |
| F4 - (Ps or Pt) Osc. Ampl / Freq | – Allows entry of the desired Amplitude and Frequency of oscillation (these values must be entered prior to starting oscillator). |

(iv) Selection of F4 for (Ps or Pt) Osc Ampl / Freq shows the “Enter Oscillation Amplitude” screen (below left). The “Enter Oscillation Frequency” screen (below right), is accessed by selecting F1 (FREQ) on the previous (left) screen. Test parameters that can be set up at these screens are:

Enter Oscillation	
Amplitude	
> 0	XX*
FREQ	

F1

F2

F3

F4

Enter Oscillation	
Frequency	
> 1.00	Hz
AMPL	

F1

F2

F3

F4

* either ft or kts

DPS500/DPS501 INSTRUCTION MANUAL

Amplitude format:	Enter value of Amplitude in ft or knots.
Frequency format:	Enter value of Frequency in Hz. Frequency values will typically be less than 1 Hz.
Typical Frequencies:	1 Hz = Completes a full Amplitude pressure cycle 60 times per minute. 0.10 Hz = Completes a full Amplitude pressure cycle 6 times per minute.

CAUTION: ENSURE THE PROPER AIRCRAFT LIMITS HAVE BEEN PROGRAMMED AND SELECTED SO OSCILLATION AMPLITUDE AND FREQUENCY DOES NOT CAUSE DAMAGE TO THE SENSITIVE AIRCRAFT INSTRUMENTS BY CREATING EXCESSIVE AIRSPEED RATES AND VSI VALUES.

Note: After a numerical value such as Amplitude or Frequency has been entered via the keyboard the ENTER key must be pressed so the value is accepted by the DPS500/501. If the ENTER key is not pressed the entry will not be saved.

- (v) After entry of the Amplitude and Frequencies, Press CLEAR / QUIT to toggle back to the Oscillator menu.

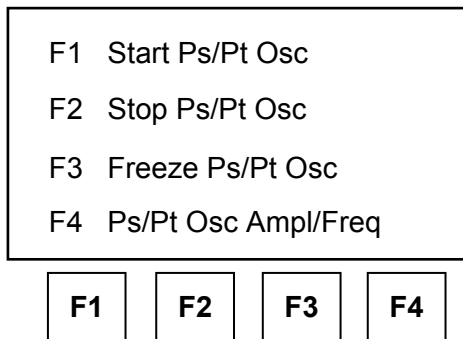

- (vi) Press the F1 (Start Ps or Pt Osc) to begin the oscillation.

Once the Oscillator has been started, repeatedly press CLEAR / QUIT until the user display returns. The Oscillation can only be viewed in the user display. To Stop the Oscillation, access the Oscillator Setup Menu and select "Stop Ps or Pt Osc."

- (d) F4 – More: Advances the screen to SETUP Menu #2 (Setup + F4), which is explained on next pages.

DPS500/DPS501 INSTRUCTION MANUAL

2. SETUP Menu #2

Setup Menu # 2 is accessed by pressing the SETUP key on the middle right side of the Remote Handheld Terminal or the lower middle on the Main Key Pad then selecting **F4 MORE**. Once the SETUP key and **F4 MORE** are entered, the following SETUP functions are then available:

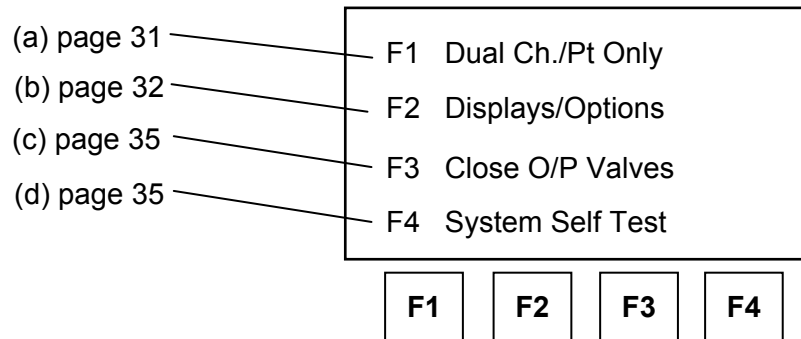

Note: Word for F3 will be either “Close” or “Open” depending on valves status.

Below is an operational description of the functions accessed in *SETUP menu #2*: The information inside the brackets represents the sequence of buttons that needs to be pressed to perform the Setup function or operation.

- (a) F1 – Dual Channel / Pt Only: Settings for Dual Channel or “Pt only” Operation. [Setup + F4 (More) + F1]

Dual Channel is the normal mode of operation where both Ps and Pt outputs are operational and can be connected to the unit or aircraft system under test.

The “Pt Only” setting is used to test instruments such as airspeed indicators with only the Pt output connected. When using “Pt Only”, the blanking cap on the DPS500 must be removed from the Ps output so that Ps is open to atmosphere. In the “Pt Only” mode, all functions associated with the Ps channel are disabled.

DPS500/DPS501 INSTRUCTION MANUAL

- (b) F2 – Displays / Options: Allows adjustment of the Displays appearance [Setup + F4 (More) + F2]

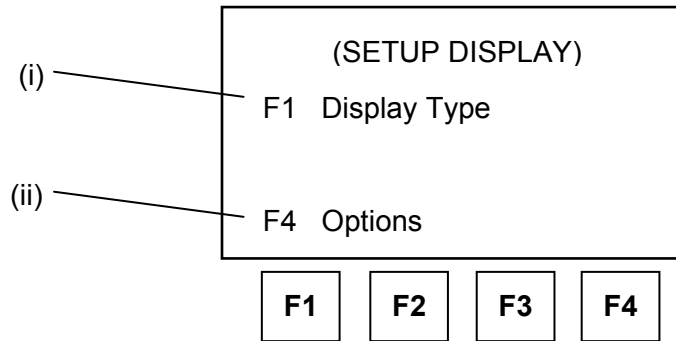

- (i) F1 – Display Type: Allows, in a screen like that shown below, the selection of how the DPS500/501 displays the aeronautical and pressure parameters.

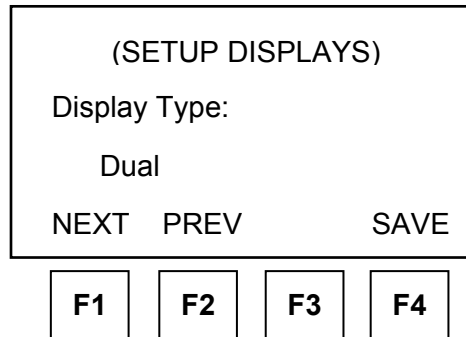

Use the F1-NEXT and F2-PREV keys to step through the available displays until the desired display type is shown. Press SAVE to select the desired display type.

DPS500/DPS501 INSTRUCTION MANUAL

Available Display Types:

1. Single: Displays a single Pressure or Aeronautical parameter and corresponding AIM / Leak Measure, as shown below.

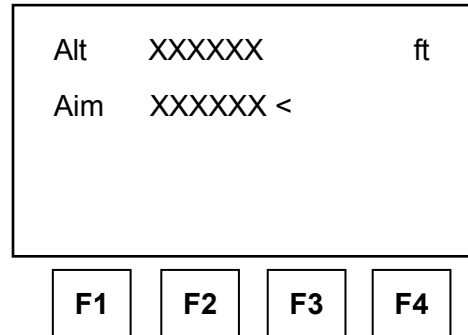

2. Dual: Displays two Pressure or Aeronautical parameters and corresponding AIM / Leak Measure, as shown below.

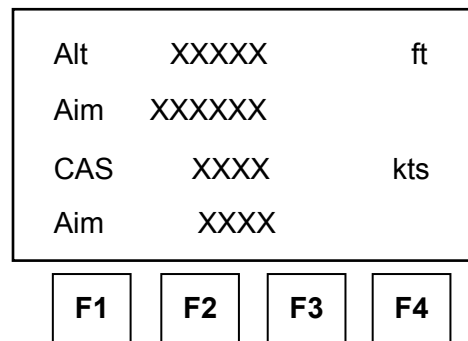

Two tables below indicate the sequence of keys needed, at this screen, to obtain the desired upper and lower displays.

Aeronautical Units Dual Display

1 st Key Press	2 nd Key Press	Upper Display	Lower Display
ALT	SPEED	Alt	CAS or TAS
ALT	MACH	Alt	Mach
Key from Table	ROC	Alt	ROC
SPEED	RATE	CAS or TAS	Rate CAS
MACH	RATE	Mach	Rate Mach Not Available
SPEED	MACH	Mach	CAS or TAS
SPEED	ALT	Alt	CAS
MACH	ALT	Alt	Mach
MACH	SPEED	Mach	CAS

DPS500/DPS501 INSTRUCTION MANUAL

Pressure Units Dual Display

1 st Key Press	2 nd Key Press	Upper Display	Lower Display
Ps	Qc	Ps	Qc
Ps	Pt	Ps	Pt
Ps	EPR	Ps	EPR
Any Key	Rate Ps	Ps	Rate Ps
Qc	Rate	Qc	Rate Qc
Pt	Rate	Pt	Rate Pt
EPR	Rate	EPR	Rate EPR
Pt	Qc	Pt	Qc
Qc	Ps	Ps	Qc
Pt	Ps	Ps	Pt
EPR	Ps	Ps	EPR
Qc	Pt	Pt	Qc

3. Triple: Displays combinations of three parameters, depending on the sequence of keys pressed, as indicated in the tables below.

Aeronautical Units Triple Display

1 st Key Press	2 nd Key Press	Top Three Lines of Display
Key from Table	SPEED	Alt, CAS or TAS
Key from Table	MACH	Alt, CAS or TAS & Mach
Key from Table	ROC	Alt, CAS or TAS & ROC
SPEED	RATE	Alt, CAS or TAS & Rate CAS
SPEED	ALT	Alt, CAS or TAS

Pressure Units Triple Display

1 st Key Press	2 nd Key Press	Top Three Lines of Display
Key from Table	Qc	Ps, Qc
Key from Table	Pt	Ps, Qc & Pt
Ps	EPR	Ps & EPR
Key from Table	ROC	Ps, Qc & Rate Ps
Qc	RATE	Ps, Qc & Rate Qc
Pt	RATE	Ps, Pt & Rate Pt
EPR	RATE	Ps, EPR & Rate EPR
Qc	Ps	Ps, Qc
EPR	Ps	Ps, EPR

4. Encoder (Optional Equipment)
5. ARINC-429 (Optional Equipment)

- (ii) F4 – Options: Allows changes to optional hardware (IEEE-488, ARINC-429) that may be fitted with the DPS500/501.

DPS500/DPS501 INSTRUCTION MANUAL

(c1) F3 – Close O/P Valves: Allows Closing of Output valves [Setup + F4 (More) + F3]

This function closes the Ps and Pt valves to enable leak checking of the internal pneumatics of the DPS500/501, with the aircraft system isolated, but still connected. All the normal functions of the DPS500/501 may be used in this mode.

Note: When conducting a leak test with the DPS500/501 O/P valves closed, it is recommended that **F3** (5 min wait and 1 min test) in the RATE TIMER function be used. Due to the limited amount of volume in the DPS500/501, heat is generated by the compressing air during the climb and will cause erroneous leak test readings (sometimes above 40 ft/min @ 20K ft.). The 5 minute wait before conducting the actual test allows the heat to dissipate so it does not affect the accuracy of the leak test.

Note: For Safety, the output valves can only be opened or closed when the DPS500/501 is at ground or ambient pressure. The aircraft system will be vented when the valves are closed.

(c2) F3 – Open O/P Valves: Allows opening Output valves [Setup + F4 (More) + F3]

This function opens the Ps and Pt valves after the CLOSE OUTPUT VALVES function.

Note: For Safety, the output valves can only be opened when the DPS500/501 is at ground or ambient pressures.

(d) F4 – System Self Test: Launches a System Self Test [Setup + F4 (More) + F4]

This function starts a self-test, the system pressures must be at or near ground pressure and the controllers selected off. The self-test is the same test routine performed during the power up initialization.

Note: At the end of the self-test the output valves will be open.

DPS500/DPS501 INSTRUCTION MANUAL

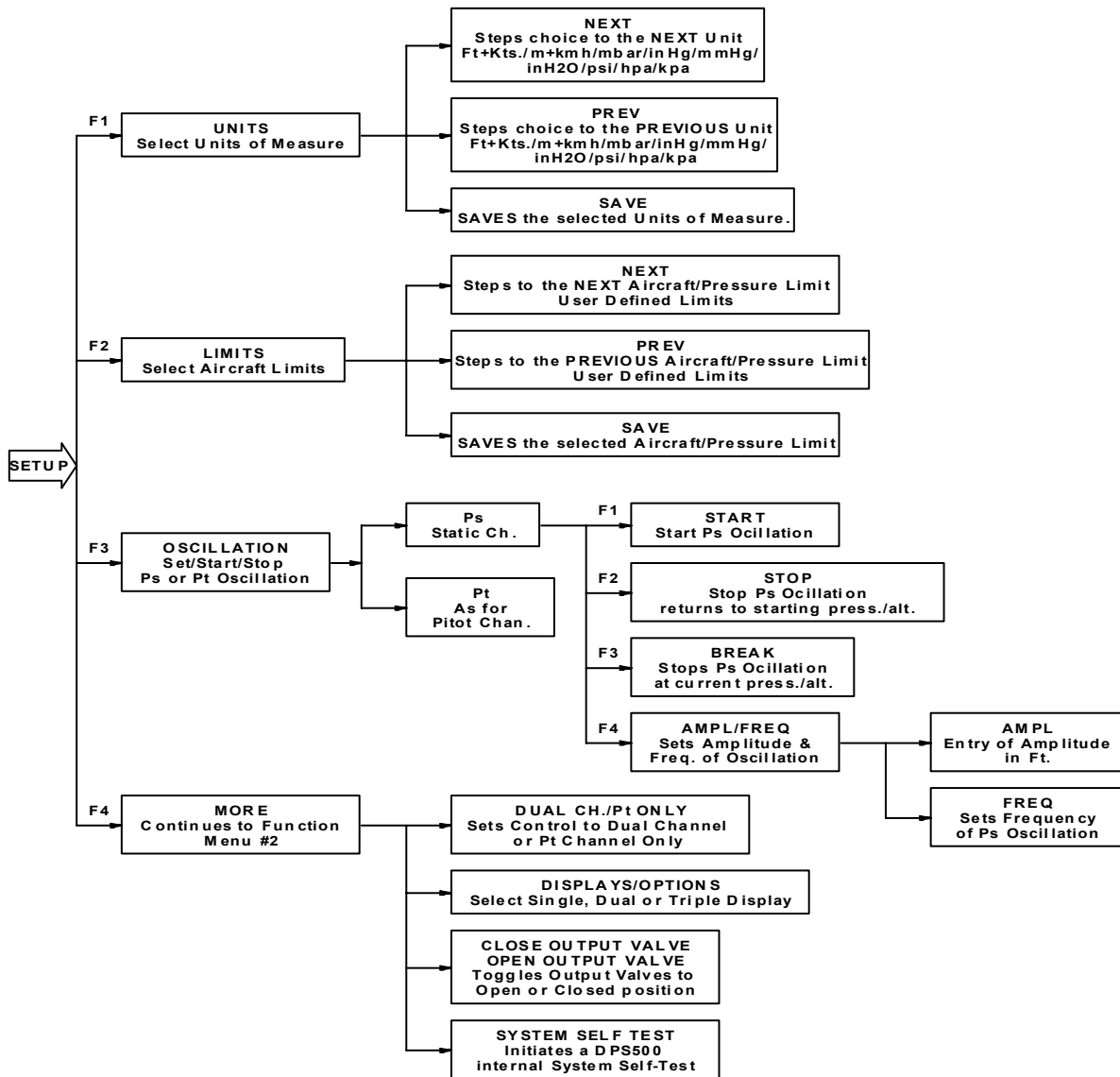

Figure 8 DPS500/501 Menu Setup Quick Reference Flowchart

DPS500/DPS501 INSTRUCTION MANUAL

B. DPS500/501 KEY SETUP

To extend the SETUP capabilities of the DPS500/501, further menus and setup features are available under certain direct key setups, as indicated in Figure 9. To access direct key SETUP, press SETUP then the desired key (ALT, SPD, MACH, etc). The setup of each key relates to the normal user mode function of that key. As an example of a Direct Key setup, pressing SETUP then the ALT / Ps key, is used to change the Altitude Correction value.

For quick reference, a tree diagram of the direct key setup is shown on Figure 10, page 48.

Once a parameter has been changed under SETUP, use CLEAR / QUIT to return to the proceeding menu. After all required parameters have been changed, repeatedly press CLEAR / QUIT until the user display returns.

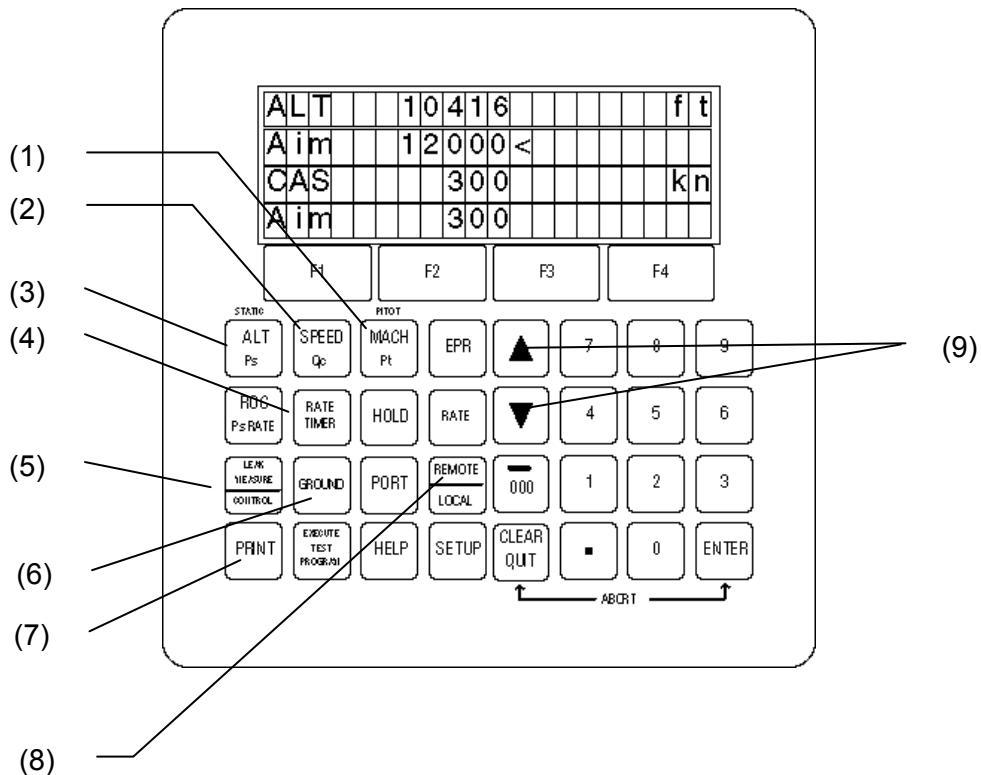
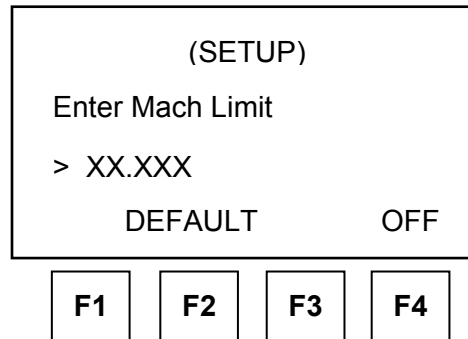

Figure 9 Keys for which the Direct Key Setup capability is operational

Note: Keys numbered correspond to paragraphs on pages 38 to 47.

DPS500/DPS501 INSTRUCTION MANUAL

1. MACH / Pt Key Setup



From time-to-time the maintenance technician may need to change the Mach Limit value to perform tests such as the Mach overspeed which may require a Mach value above the selected Aircraft Limits. The MACH Key Setup function allows for the default Mach limit to be changed or disabled for these situations. The initial Mach limit is set by the Default limit or the currently selected aircraft limits. Below is the step-by-step process to changing the Mach limit:

The following steps describe the step-by-step process for changing or adjusting the current Mach limit:

- (a) Press SETUP key.
- (b) Press the MACH / Pt key.
- (c) To change the Mach limits, enter a numeric value or select one of the following:

Note: After a numerical value such as Mach has been entered via the keyboard the ENTER key must be pressed so the value is accepted by the DPS500 / 501. If the ENTER key is not pressed the entry will not be saved.

- (i) **DEFAULT** Selecting **F2**, Returns the Mach Limit value back to the Default aircraft limits value (Does not revert back to selected aircraft limit).
- (ii) **OFF** Selecting **F4**, Disables the Mach Limit Feature (When OFF is displayed above F4)
- (iii) **ON** Selecting **F4**, Enables the Mach Limit Feature (When ON is displayed above F4). Returns the Mach Limit value back to the Default aircraft limits value (Does not revert back to selected aircraft limit).

Once a parameter has been changed under SETUP, use CLEAR / QUIT to return to the proceeding menu. After all required parameters have been changed, repeatedly press CLEAR / QUIT until the user display returns.

DPS500/DPS501 INSTRUCTION MANUAL

2. SPEED / Qc Key Setup

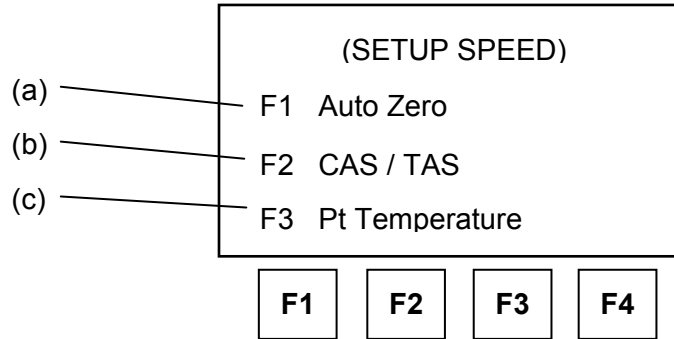

The SPEED / Qc Key Setup function allows temporary alteration of the Auto Zero, CAS / TAS and Pt Temperature settings. The following describes these functions:

(a) F1 – Auto Zero

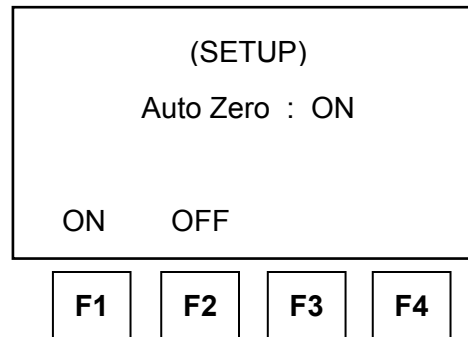

F1 – ON: Enables the Auto Zero function.

F2 – OFF: Disables the Auto Zero function.

The Auto Zero Function optimises airspeed accuracy at low airspeeds. When enabled, the DPS500/501 performs an Auto Zero as long as:

1. Ps and Pt pressures are stable.
- 2a. If in control mode, a zero airspeed or Qc aim has been achieved.
- 2b. If in measure mode, the airspeed is less than 20 knots (or Qc equivalent).

The auto zero will be initiated within one minute of achieving a new aim value and thereafter, every five minutes.

The auto zero sequence can be interrupted at any time by entering a new command over the keypad or option interface.

The controllers must be in measure mode when enabling or disabling the Auto Zero function.

DPS500/DPS501 INSTRUCTION MANUAL

(b) F2 – CAS / TAS

This DPS500/501 function changes the airspeed display between Calibrated Air Speed (CAS or V_c) and True Air Speed (TAS or V_t). For testing purposes, CAS is equivalent to Indicated Air Speed (IAS).

The value of TAS displayed depends on Pt temperature, so a correct Pitot temperature must be entered via pressing **F3**.

(c) F3 – Pt Temperature

This function allows the value of Pt temperature to be entered. This value is used in the calculation of TAS.

Enter the Pitot temperature measured by the aircraft's Pitot temperature sensor in the units shown on the display.

Note: After a numerical value such as Pt Temperature has been entered via the keyboard the ENTER key must be pressed so the value is accepted by the DPS500/501. If the ENTER key is not pressed the entry will not be saved.

The default unit, °C or °F, is changed using the Configuration Function (page 52).

Once a parameter has been changed under SETUP, use CLEAR / QUIT to return to the proceeding menu. After all required parameters have been changed, repeatedly press CLEAR / QUIT until the user display returns.

3. ALT/Ps Key Setup (Altitude Correction)

The altitude correction facility improves the overall accuracy of static channel testing by eliminating the pressure error caused by the DPS500 / 501 and the aircraft system or instrument under test being at different heights. Examples of this distance are shown in Figures 18 and 19 (page 82).

Enter Height of
Instrument Above
ADTS
> XX ft

F1

F2

F3

F4

DPS500/DPS501 INSTRUCTION MANUAL

This function allows for manually setting the Altitude Correction value or adjusting the height because the test set is at a different height than the standard level. Example: The standard position of the DPS500/501 during testing is on a cart. The DPS500/501 has moved to the ground for the current test and requires the altitude correction to be entered or changed to compensate for the difference in height. The following procedure describes the step-by-step process for temporarily changing or adjusting the current Altitude Correction value:

- (a) Press the SETUP key.
- (b) Press the ALT / Ps key.
- (c) To change the Altitude Correction value, enter a numeric value of the height of the aircraft system above or below the DPS500 / 501 reference level. (If the aircraft system is below the DPS500/501, enter the value as a negative number).

Note: After a numerical value such as Altitude Correction has been entered via the keyboard the ENTER key must be pressed so the value is accepted by the DPS500/501. If the ENTER key is not pressed the entry will not be saved.

Another way the Altitude correction can be set is through the Aircraft Limits Setup. Assuming the DPS500/501 will have a standardised testing position (Floor, Cart, etc.) the altitude correction value was introduced as a data value in the Aircraft Limits function. If the test set is properly configured with a users aircraft database (altitude correction value included), the altitude correction value for a specific aircraft application can be established when an Aircraft Limit is selected. See "Altitude Correction through Limit Setup" on page 83 for a description and procedure for selecting an Aircraft Limit. Configuration of the Altitude Correction & Aircraft Limits is on page 53, "Limits".

4. RATE TIMER Key Setup

The Rate Timer function is the timing facility used for performing Pitot and Static system leak testing. The [SETUP] [RATE TIMER] function permits adjustment of the WAIT (Time allowed for system pressures to stabilise) and TIME (Actual Leak Test Timer) values for **F1**, **F2**, and **F3**.

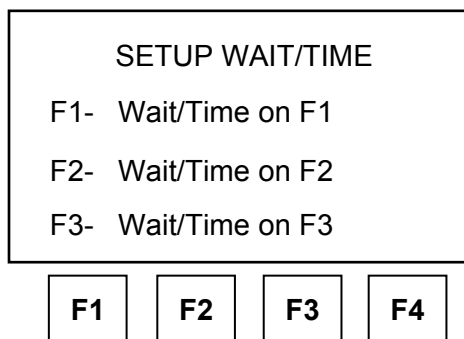

DPS500/DPS501 INSTRUCTION MANUAL

To temporarily change the leak testing times:

- (a) Press the SETUP key
- (b) Press the RATE TIMER key.
- (c) Select which time value is to be changed: **F1**, **F2** or **F3**.
- (d) Enter the WAIT TIME in minutes and seconds. Enter 00:00 if a wait is not required.

Note: To enter a time less than 10 minutes, enter a zero, then the time.
Examples: 1 minute = 0100; 2 minutes = 0200; 10 minutes = 1000

- (e) Press ENTER

Note: After a numerical value such as WAIT has been entered via the keyboard the ENTER key must be pressed so the value is accepted by the DPS500 / 501. If the ENTER key is not pressed the entry will not be saved.

- (f) Select TIME.
- (g) Enter the TIME value in minutes and seconds.
- (h) Press ENTER

Note: After a numerical value such as TIME has been entered via the keyboard the ENTER key must be pressed so the value is accepted by the DPS500/501. If the ENTER key is not pressed the entry will not be saved.

- (i) Press CLEAR / QUIT.
- (j) Select another WAIT / TIME or press CLEAR / QUIT.

Once a parameter has been changed under SETUP, use CLEAR / QUIT to return to the proceeding menu. After all required parameters have been changed, repeatedly press CLEAR / QUIT until the user display returns.

5. LEAK MEASURE/CONTROL Key Setup

This function temporarily (because the Test Set reverts back to its default settings after being turning power off and on) enables and disables the Auto Leak and Auto Limit recovery facilities. This function is started at the screen shown on the next page.

DPS500/DPS501 INSTRUCTION MANUAL

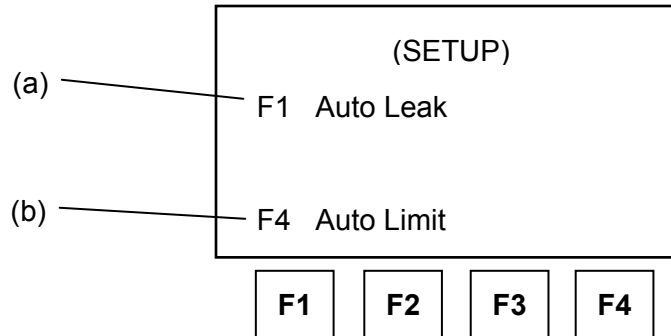

(a) F1 – Auto Leak

The Auto Leak function is a critical safety feature of the DPS500/501 designed to automatically protect sensitive pressure instruments from damage caused by excessive leaks. The DPS500 / 501 is fully automated, meaning that the unit achieves and maintains an altitude, airspeed or other datum point while overcoming the pressure losses caused by leaks in a system. Many times the only opportunity a maintenance technician can see a leak on the LCD display is when the unit has been toggled between CONTROL mode and LEAK MEASURE mode. While the DPS500 / 501 is in the LEAK MEASURE mode the unit periodically checks for a leak exceeding 3000 ft/min or 300 knots/min. If the value exceeds this set parameter then DPS500 / 501 automatically toggles to the CONTROL mode and uses the available pump pressure and flow to stabilize the system. An Excessive Leak message is displayed to the technician to inform him/her of the trouble. Since the unit toggles back into the CONTROL mode the system can then be returned to ambient pressure or the technician can begin troubleshoot the leak. This SETUP feature allows the Auto Leak recovery to be turned off if not required.

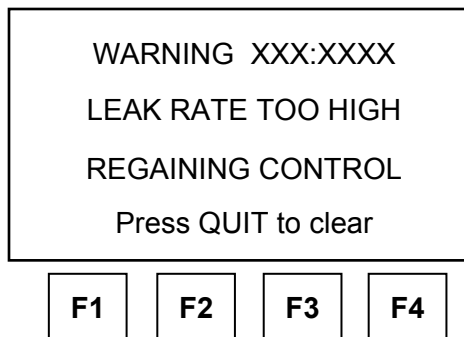

CAUTION: TURNING THE AUTO LEAK FUNCTION OFF IS NOT RECOMMENDED SINCE IT IS A SAFETY FEATURE TO PROTECT SENSITIVE AIRCRAFT SYSTEMS FROM DAMAGE.

DPS500/DPS501 INSTRUCTION MANUAL

(b) F4 – Auto Limit

Auto Limit recovery automatically regains control of the system if the pressure on either channel leaks outside of the selected limits.

Example: The DPS500/501 has been set to 10,000 ft and 440 knots. The unit is placed in the LEAK MEASURE mode. The Aircraft Limits selected for this test has a maximum of 445 knots for the aircraft under test. If a leak or other factors cause the airspeed to rise above the 445 ft. limit, the DPS500 / 501 automatically regains control and displays the following message:

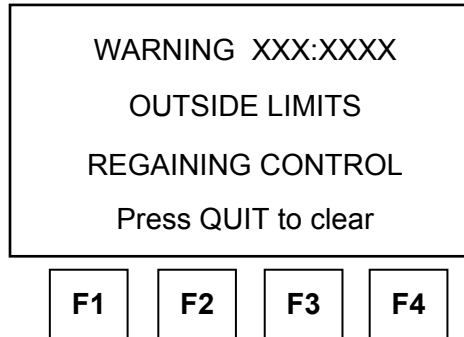

Auto Limit recovery may be temporarily turned off if not required using SETUP, LEAK MEASURE / CONTROL. Once a parameter has been changed under SETUP, use CLEAR/QUIT to return to the proceeding menu. After all required parameters have been changed, repeatedly press CLEAR / QUIT until the user display returns.

6. GROUND Key Setup

This function enables the physical station altitude to be entered for calculation of the current Pressure at Sea Level (QNH). See "GROUND", page 15, for further details.

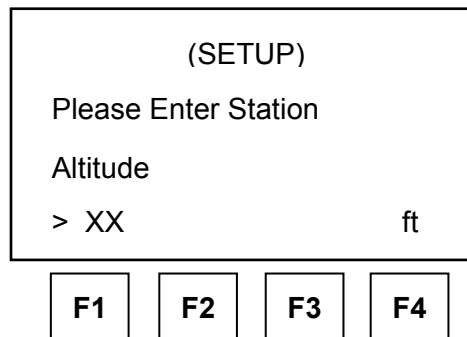

DPS500/DPS501 INSTRUCTION MANUAL

Enter the station (airfield) altitude in the units shown on the display. The displayed units may be changed to meters by following instructions indicated on “F1 - Units”, page 27.

Note: After a numerical value such as Station Altitude has been entered via the keyboard the ENTER key must be pressed so the value is accepted by the DPS500/501. If the ENTER key is not pressed the entry will not be saved.

Once a parameter has been changed under SETUP, use CLEAR / QUIT to return to the proceeding menu. After all required parameters have been changed, repeatedly press CLEAR / QUIT until the user display returns.

7. PRINT Key Setup

This function allows the system time and date to be set. A battery-backed clock maintains the time and date while the DPS500/501 is powered down.

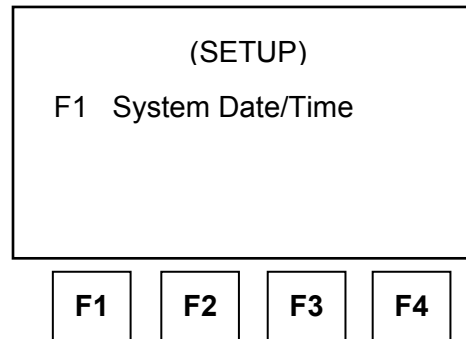

To setup the system time and date, using screens like those shown below:

- (a) Use [TIME] to [DATE] to select between time and date.
- (b) To change the time or date, enter the 6 digit Date or Time and press ENTER.
- (c) The date format is month / date / year.
- (d) The time format is hours / min / seconds.

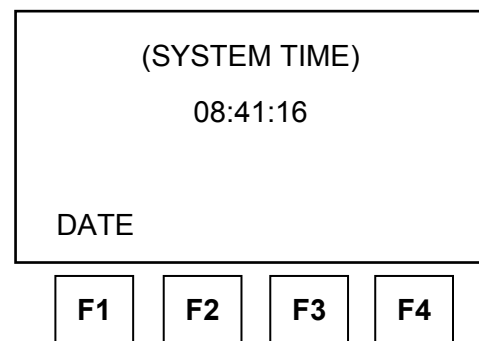
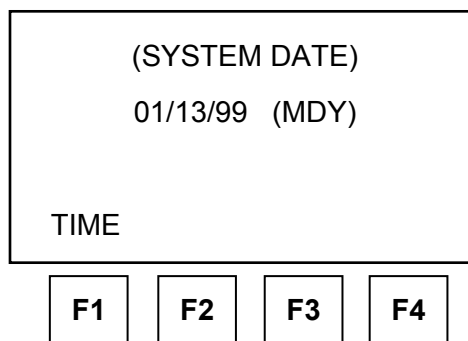

DPS500/DPS501 INSTRUCTION MANUAL

Note: After a numerical value such as SYSTEM DATE or SYSTEM TIME has been entered via the keyboard the ENTER key must be pressed so the value is accepted by the DPS500/501. If the ENTER key is not pressed the entry will not be saved.

Once a parameter has been changed under SETUP, use CLEAR / QUIT to return to the proceeding menu. After all required parameters have been changed, repeatedly press CLEAR / QUIT until the user display returns.

8. RATE Key Setup

(SETUP)			
Automatic Airspeed			
Rate : OFF			
ON	OFF		
F1	F2	F3	F4

F1 ON: When enabled, the airspeed rate automatically tracks the altitude

F2 OFF: Disables the Automatic Airspeed function

This function selects automatic airspeed rate control ON or OFF.

If the automatic airspeed rate is selected (Using SETUP, RATE) the airspeed rate is automatically adjusted to simultaneously achieve both altitude and airspeed aim values. This adjustment normally requires a reduction in the CAS / TAS rate from the aim value; the rate does not exceed the aim value. When airspeed (not Pt) is automatically reduced, the display shows **(A)** after RATE CAS Aim.

Once a parameter has been changed under SETUP, use CLEAR / QUIT to return to the proceeding menu. After all required parameters have been changed, repeatedly press CLEAR / QUIT until the user display returns.

DPS500/DPS501 INSTRUCTION MANUAL

9. Nudge Up (▲) and Nudge Down (▼) Keys Setup

This function allows the authority of the NUDGE key to be temporarily adjusted for the parameters indicated below.

In aeronautical units, only the aeronautical parameters are available. These are:

ALT ROC CAS / TAS RATE CAS MACH

In pressure units, only the pressure parameters are available. These are:

Ps RATE Ps Pt Qc RATE Qc EPR RATE EPR

The procedure to adjust the NUDGE keys using the screen shown below, is as follows:

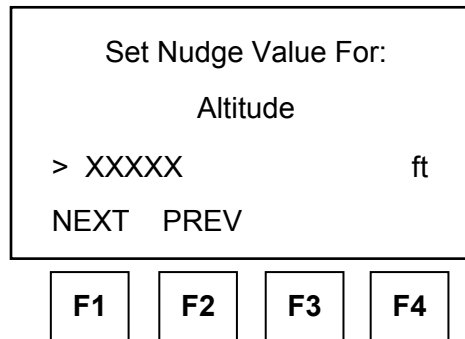

(a) When SETUP then NUDGE is pressed, the display will show the current value of the NUDGE for the parameter last displayed (i.e. if ALT was the last parameter selected then ALT nudge value would be displayed).

(b) Each parameter is displayed with the current value. Enter a new value to replace the present value or use the CLEAR / QUIT button to return to the user display.

Note: After a numerical value for the NUDGE value has been entered via the keyboard the ENTER key must be pressed so the value is accepted by the DPS500/501. If the ENTER key is not pressed the entry will not be saved.

(c) Use F1 [NEXT] or F2 [PREV] to display other parameters.

(d) Press QUIT when the NUDGE values of all required parameters have been changed.

Once a parameter has been changed under SETUP, use CLEAR/QUIT to return to the proceeding menu. After all required parameters have been changed, repeatedly press CLEAR/QUIT until the user display returns.

DPS500/DPS501 INSTRUCTION MANUAL

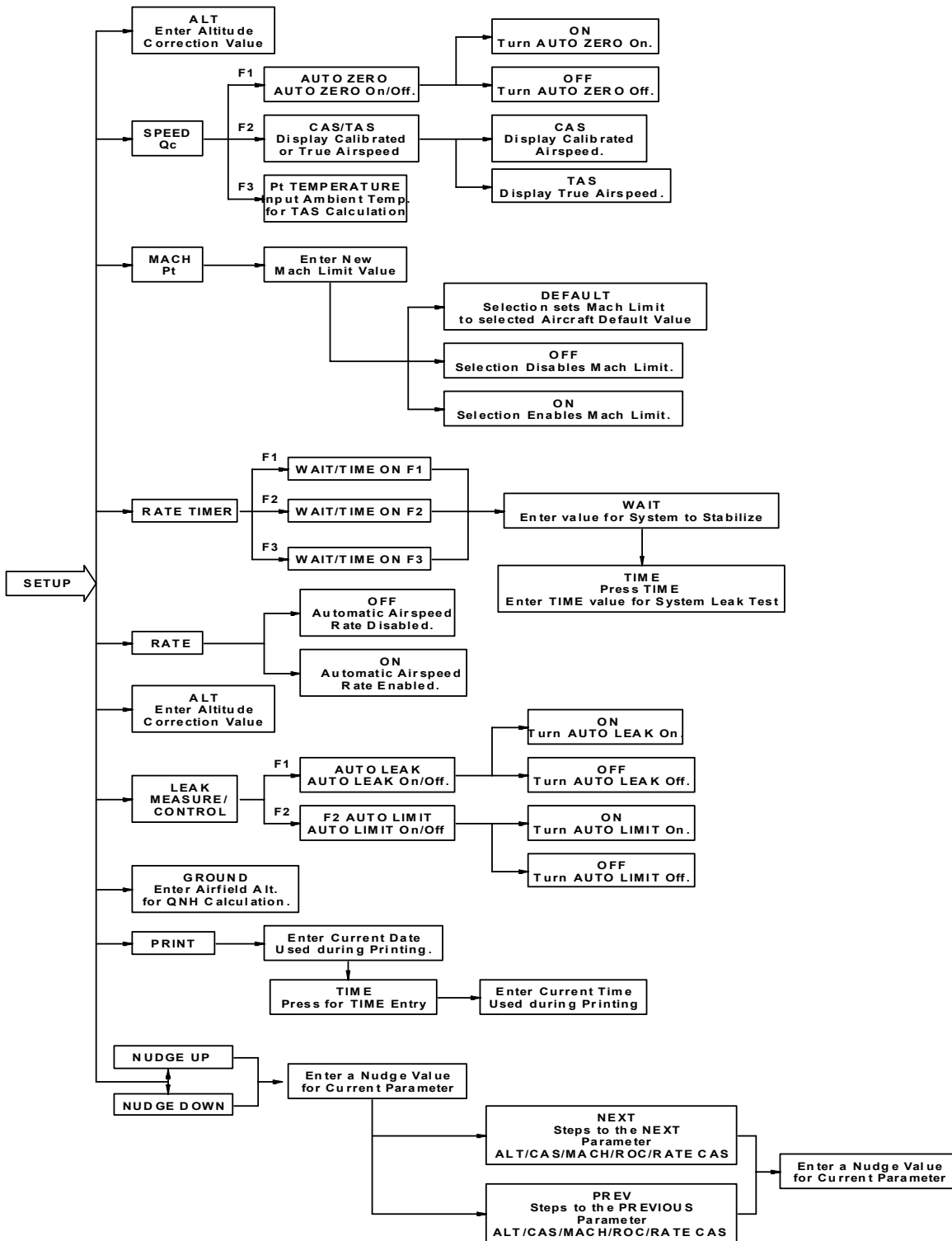

Figure 10 DPS500/501 Key Setup Quick Reference Flowchart

DPS500/DPS501 INSTRUCTION MANUAL

2. DPS500/501 CONFIGURATION

The SETUP key also provides access to the CONFIGuration (Default mode). CONFIG is very similar to SETUP with many identical functions. The major difference is that changes made under CONFIG are stored in non-volatile memory so they are not lost at power-down. CONFIG is primarily used to change the power-up default settings of the ADTS functions so the DPS500 / 501 would power up in a specified state.

Most SETUP parameters are available also under CONFIG. However, some setup parameters are only available under CONFIG.

Certain parameters under SETUP can be locked from CONFIG so that the user can not inadvertently change them. An example of this would be Aircraft Limits where the DPS500 / 501 can be made to power-up with a particular set of limits that can not be changed. If the user tries to change a parameter that is locked, a warning is given.

The **F1**, **F2**, **F3** & **F4** just below the DPS501 Controller and / or Remote Handheld Terminal LCD displays are function keys or soft-keys used to select choices from the SETUP or CONFIG menus. The menu choices may be displayed in the standard format selected by pressing the Function Key corresponding to the listed operation on the LCD (left display) or by pressing the Function Key directly below the desired operation (right display), both menu types are shown below.

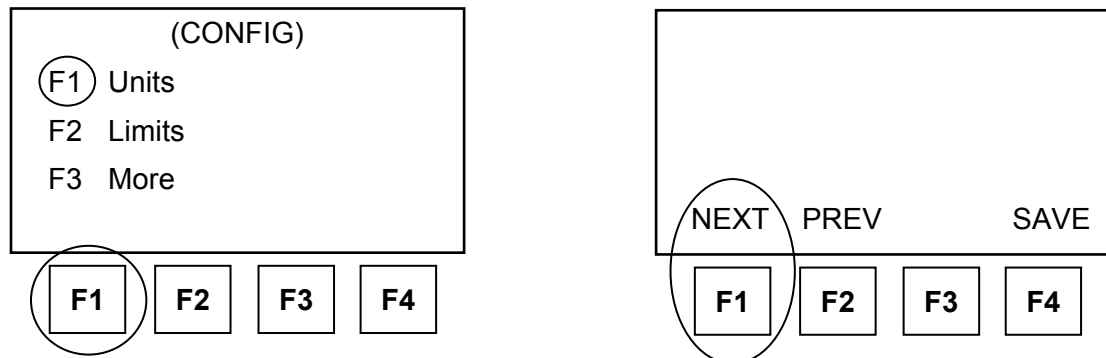

For quick reference, tree diagrams of the Menu CONFIG (page 62) and Direct Key CONFIG (page 70) functions are provided at the end of the applicable section.

DPS500/DPS501 INSTRUCTION MANUAL

A. DPS500/501 CONFIGURATION MENU

To enter the CONFIG Function of the DPS500/501 press and hold the F1 function key then press the SETUP key on the middle right side of the Remote Handheld Terminal or the lower middle on the Local Key Pad. Once the F1 + SETUP keys have been pressed, CONFIG functions are then available from both the CONFIG menus and directly by pressing certain keys. Sections (1) and (2) describe how to select the functions accessible through the CONFIG menu #1 and CONFIG menu #2. A quick reference for these menus is shown on Figure 11, page 62.

1. CONFIG Menu #1

CONFIG Menu #1 is in the standard format. When the menu is displayed, press the corresponding Function Key (**F1** displayed = **F1** key, etc) to select the desired operation or function.

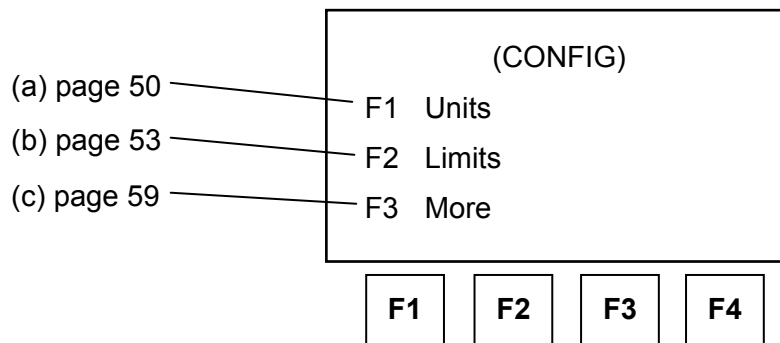

Below is an operational description of the functions accessed by using the *F1 + SETUP* keys (*CONFIG functions*) plus the corresponding Menu item listed below: The information inside the brackets represents the sequence of buttons pressed to perform the Setup function or operation.

(a) F1 – Units [(Hold F1, Press Setup) + F1].

This function allows the Default values of the DPS500/501 units to be configured, as shown in the screen below.

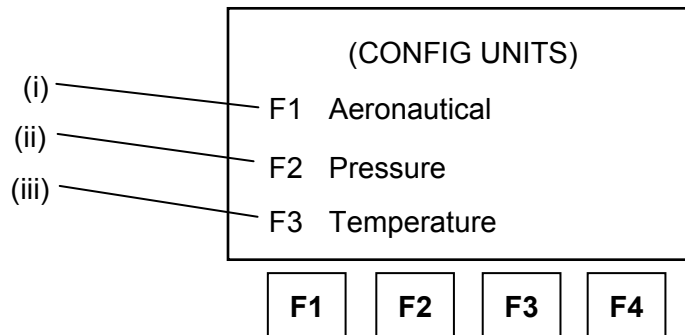

DPS500/DPS501 INSTRUCTION MANUAL

(i) **F1 - Aeronautical**

Default aeronautical units are used at power-up for display of Altitude and Airspeed. The default units are used for entry of aircraft limits in CONFIG and entry of any altitude or airspeed related functions in SETUP or CONFIG modes.

As shown in the screen below, use the F1-NEXT and F2-PREV keys to step through the available aeronautical units until the display shows the desired unit. Press SAVE to select the desired unit.

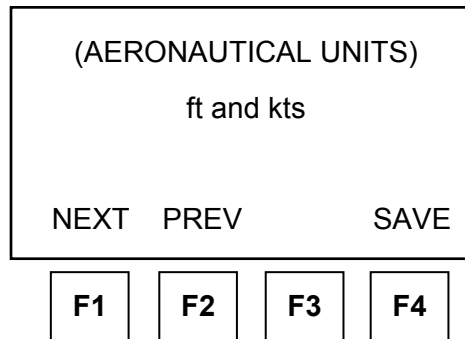

Available Aeronautical Units:

- | | |
|----------------------|---------------------|
| ft and Knots | m and km/hr (m/min) |
| ft and mph | m and km/hr (m/s) |
| m and km/hr (hm/min) | |

Once a parameter has been changed under CONFIG, use CLEAR / QUIT to return to the proceeding menu. After all required parameters have been changed, repeatedly press CLEAR / QUIT until the user display returns.

(ii) **F2 - Pressure**

The Default pressure units are used for entry of pressure limits in CONFIG and entry of any pressure values in EPR, SETUP or CONFIG. Pressure values are displayed during EPR tests, SETUP and CONFIG when units other than Aeronautical units are needed.

As shown in the screen of next page, use the F1-NEXT and F2-PREV keys to step through the available Pressure units until the display shows the desired unit. Press SAVE to select the desired unit.

DPS500/DPS501 INSTRUCTION MANUAL

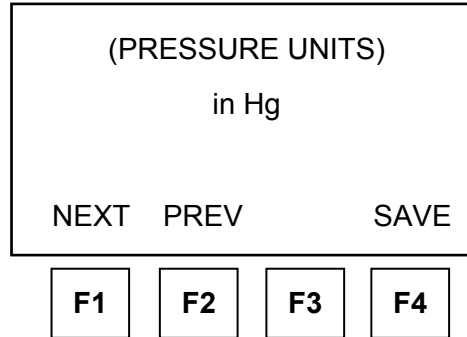

Available Pressure Units:

psi	hPa	inH ₂ O 4°C
inHg	kPa	inH ₂ O 20°C
mmHg	mbar	inH ₂ O 60°F

Once a parameter has been changed under CONFIG, use CLEAR / QUIT to return to the proceeding menu. After all required parameters have been changed, repeatedly press CLEAR / QUIT until the user display returns.

(iii) F3 - Temperature

The Default Temperature units are used for determining the temperature scale (°C or °F) to be used. Temperature values are typically necessary for the calculation of True Airspeed (TAS)

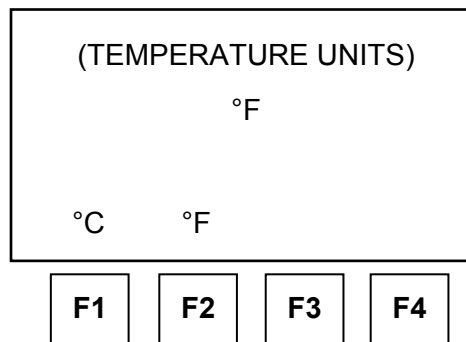

Select F1 for °C or F2 for °F.

Once a parameter has been changed under CONFIG, use CLEAR / QUIT to return to the proceeding menu. After all required parameters have been changed, repeatedly press CLEAR / QUIT until the user display returns.

DPS500/DPS501 INSTRUCTION MANUAL

(b) F2 - Limits [(Hold F1, Press Setup) + F2].

This function allows, using a screen similar to that shown below, to configure new and modify existing Aircraft Limits, to lock a set of Aircraft Limits, and to set the Default Aircraft Limit of the DPS500/501.

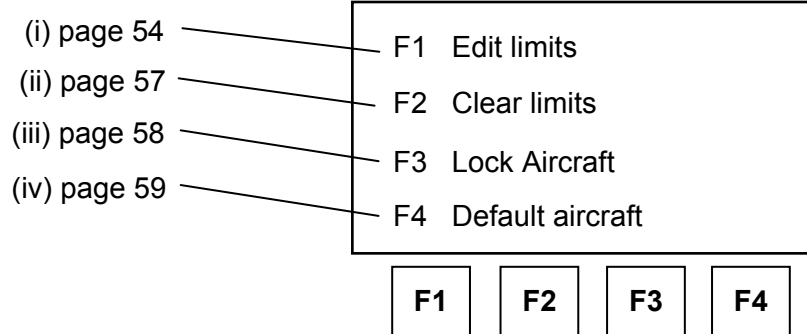

Available Limit Parameters:

Aeronautical Limits

Edit Aircraft Name
 Enter Max. Altitude
 Enter Min. Altitude
 Enter Max. CAS
 Enter Min. CAS
 Enter Max. Mach
 Enter Max. ROC
 Enter Max. Rate CAS
 ARINC Limits (ON / OFF)
 Enter Alt Correction

Pressure Limits

Enter Max. Ps
 Enter Min. Ps
 Enter Max. Qc
 Enter Min. Qc

 Enter Max. Rate Ps
 Enter Max. Rate Qc

Note: Use the applicable *Aircraft Maintenance Manual* as a reference for setting all Aircraft Limit values.

On the following pages there is an operational description of the functions accessed from this screen.

DPS500/DPS501 INSTRUCTION MANUAL

(i) F1 - Edit Limits

At the screen shown below, the available functions are described beneath it.

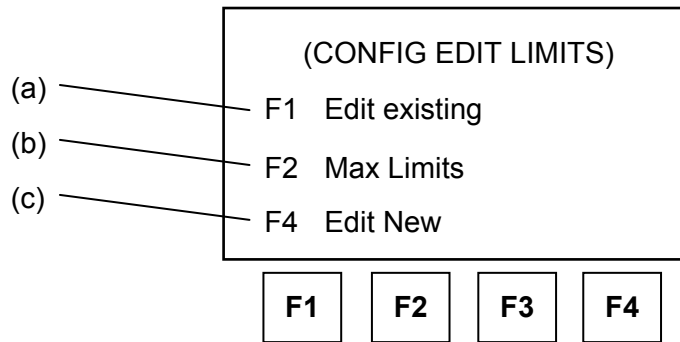

(a) F1 - Edit Existing

Displays a list of current Aircraft limits allowing the user to update or change existing Limit parameters.

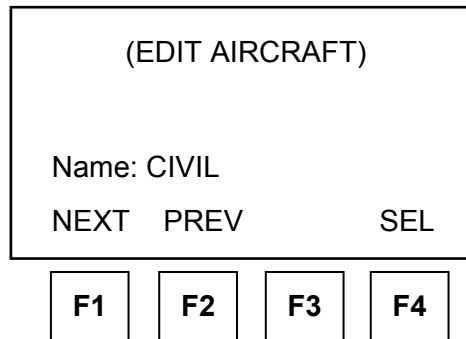

Remarks:

- Use the F1-NEXT and F2-PREV keys to step through the available Aircraft Limits until the display shows the desired unit.
- Press SEL to select the displayed aircraft Limit for editing. Refer to “F4- EDIT NEW”, starting on page 55, for individual limit descriptions.

(b) F2 – Max Limits

Selection of Max Limits automatically generates an Aircraft Limit named “MAX”. The MAX limit has the upper and lower aeronautical and pressure limits capable of being simulated by the DPS500 / 501. After generating the MAX Limit, the limit can be accessed through the Limits SETUP explained starting on page 27.

DPS500/DPS501 INSTRUCTION MANUAL

MAX is a factory-programmed limit with the following Aeronautical Limits:

Max. Altitude = 105,000 ft Min. Altitude = -3000 ft Max. CAS = 850 knots
Min. CAS = -100.0 knots Max. Mach = 12.350 Max. ROC = 100,000 ft/min
Max. Rate CAS = 2000 knots/min Altitude Correction = 0 ft

CAUTION: DUE TO THE VERY HIGH LIMITS, THE MAX LIMITS SETTING ON THE DPS500 / 501 IS NOT RECOMMENDED FOR USE WHILE CONNECTED TO AN AIRCRAFT.

(c) F4 – Edit New

Items that are possible to edit, are described in the following paragraphs.

Note: After an edited value has been entered, the ENTER key must be pressed so the value is accepted. If the ENTER key is not pressed the entry will not be saved.

Note: After a limit parameter has been displayed, or an edited value has been saved, press NEXT or PREV to step to the next or previous limit parameter.

(1) Aircraft Name (see the example screen below). Remarks:

(EDIT AIRCRAFT NAME)

Name:

NEXT PREV ALPHA BACK

F1

F2

F3

F4

- Entering an aircraft name can be accomplished by entering a numerical name such as “601” directly through the keypad.
- Selecting F3 – ALPHA and pressing the nudge keys (▲ ▼) are used to select the applicable alpha character.
- The aircraft name can contain alpha and numerical characters in any order.
- F4 – BACK is used as a backspace key for editing the name.

DPS500/DPS501 INSTRUCTION MANUAL

- (2) Enter Max Altitude, Min Altitude, Max CAS and Min CAS (see the example screen below). Enter the fundamental aeronautical limits for the aircraft (refer to aircraft maintenance manual for limits).

Enter Max Altitude	
> XXXXX	ft
NEXT	PREV

F1	F2	F3	F4
----	----	----	----

- (3) Enter Max Mach. Applies only in aeronautical mode. It can be used to set a maximum mach limit (refer to aircraft maintenance manual). If mach limit is not required, enter a high limit (i.e. 10).
- (4) Enter Max ROC & Max Rate CAS. These limits are the maximum rate of change for altitude and airspeed and only apply in aeronautical units (refer to aircraft maintenance manual for the limits).
- (5) Enter Min Ps, Max Ps, Min Qc & Max Qc. Enter the Fundamental pressure unit limits (entry not needed if Aeronautical unit limits already entered).
- (6) Enter Max Rate Ps & Max Rate Qc. These limits are the maximum rate of change for Ps and Qc and only apply in pressure units (entry not needed if Aeronautical unit limits already entered).
- (7) ARINC Limits. Setting ARINC LIMITS ON enables ARINC 565 operation limits.
- (8) Altitude Correction. This facility allows the Altitude correction value for a specific aircraft to be entered in conjunction with the selection of an aircraft limit. Enter the Altitude Correction value as described in “Manual Altitude Correction Setup” on page 81.

When all limits and associated functions are set, to save this information follow these steps:

- (1) Press [CLEAR / QUIT] to exit the limit screen.
- (2) If changes have been made, the display shows a confirmation screen, shown on next page, which needs to be answered before saving the changes.

DPS500/DPS501 INSTRUCTION MANUAL

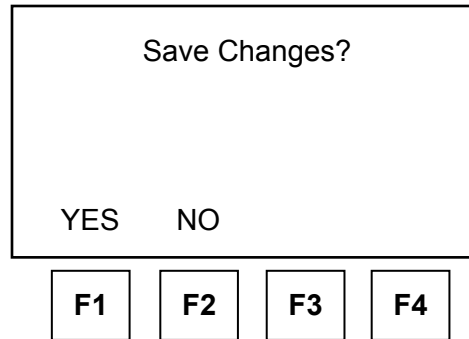

- (3) If the system detects any errors (e.g., duplicate aircraft names, values out of range or editing system-defined limits the display change to the edit screen for the error to be corrected.
- (4) Once a parameter has been changed under CONFIG, use CLEAR / QUIT to return to the previous menu. After all required parameters have been changed, repeatedly press CLEAR / QUIT until the user display returns.

(ii) F2 - Clear Limits

This function enables the user, at the screen shown below, to clear or delete an existing set of aircraft limits, by following these steps:

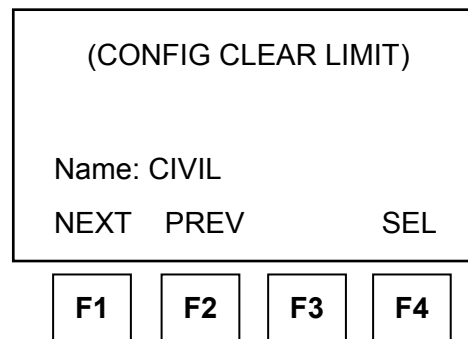

- (1) Use the F1 (NEXT) and F2 (PREV) keys to step through the current Aircraft Limits until the display shows the desired name. Press F4 (SEL) to select Aircraft Limit to be deleted. A confirmation screen, shown on the next page, will be displayed.

DPS500/DPS501 INSTRUCTION MANUAL

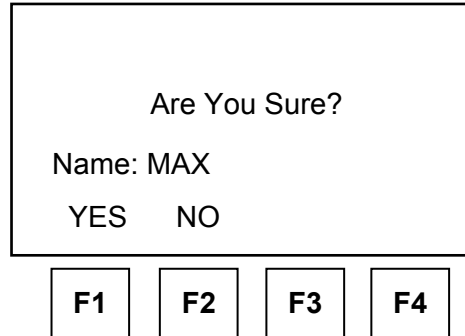

(2) Press F1 (YES) to verify the deletion, or F2 (NO) to cancel the deletion.

Note: The STANDARD and CIVIL limits are factory programmed limits which cannot be deleted. If either limit is selected the following message will be displayed.

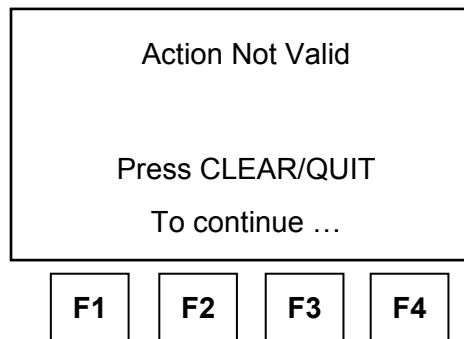

Once a parameter has been changed under CONFIG, use CLEAR / QUIT to return to the proceeding menu. After all required parameters have been changed, repeatedly press CLEAR / QUIT until the user display returns.

(iii) F3 - Lock Aircraft

This function prevents changing the Default Limit through SETUP. As a safety measure, the DPS500/501 can be locked, using the screen shown on the next page, to a single set of limits to prevent technicians from setting up the DPS500/501 with the wrong or unacceptable limits through the SETUP function. At this screen, either press F1 (ON) to lock the DPS500/501 to the default Limit value, or press F2 (OFF) to unlock the DPS500 / 501 Limits Function.

Once a parameter has been changed under CONFIG, use CLEAR / QUIT to return to the proceeding menu. After all required parameters have been changed, repeatedly press CLEAR / QUIT until the user display returns.

DPS500/DPS501 INSTRUCTION MANUAL

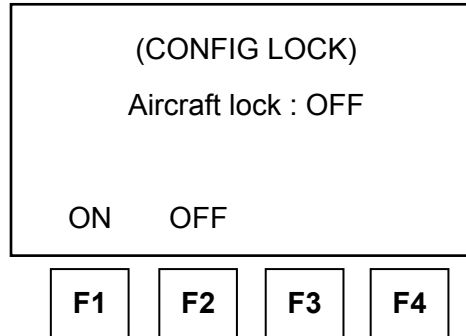

(iv) F4 - Default Aircraft

This function allows selecting, at the screen shown below, the set of limits used at power-up.

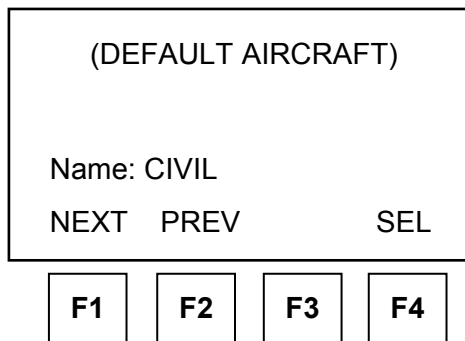

- (1) Use the F1 (NEXT) and F2 (PREV) keys to step through the current Aircraft Limits until the display shows the desired name.
- (2) Press SEL to select Aircraft Limit to be the Default aircraft.

Once a parameter has been changed under CONFIG, use CLEAR / QUIT to return to the preceding menu. After all required parameters have been changed, repeatedly press CLEAR / QUIT until the user display returns.

- (c) F3 – More: Advances to CONFIG Menu #2. [(Hold F1, Press Setup) + F3].

DPS500/DPS501 INSTRUCTION MANUAL

2. CONFIG Menu #2

CONFIG Menu #2, shown on next page, is accessed by pressing the SETUP key while holding the F1 key down, then selecting the F3 (MORE) key. Once the CONFIG Menu #2 is accessed, the following CONFIG functions are available:

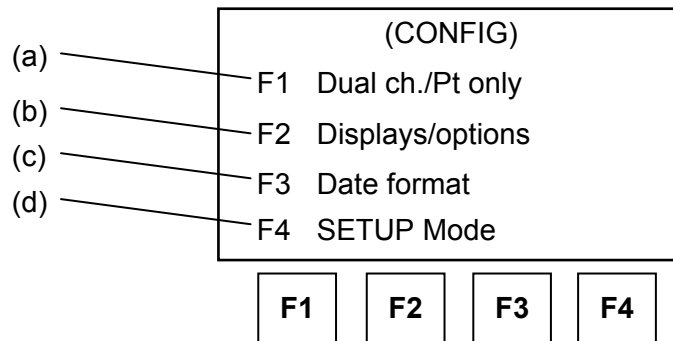

Below is an operational description of the functions accessed through CONFIG Menu #2: (The information in the brackets represents the sequence of buttons pressed to perform the CONFIG function or operation.)

- | | | |
|---|---|---|
| (a) F1 - Dual Channel / Pt Only
[(Hold F1, Press Setup) + F3 + F1] | – | CONFIG equivalent of SETUP function, page 31. |
| (b) F2 - Displays / Options
[(Hold F1, Press Setup) + F3 + F2] | – | CONFIG equivalent of SETUP function, page 32. |
| (c) F3 – Date Format
[(Hold F1, Press Setup) + F3 + F3] | – | Configuration of Date Format (DD/MM/YY or MM/DD/YY) |
| (d) F4 – SETUP mode
[(Hold F1, Press Setup) + F3 + F4] | | |

This last option enables a supervisor to place access limitations on the DPS500 / 501 SETUP menus. After selecting SETUP mode, the screen shown on the next page is displayed, where the following actions can be taken:

DPS500/DPS501 INSTRUCTION MANUAL

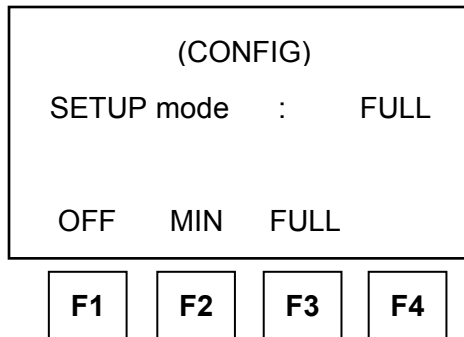

- F1 – OFF Turns OFF all access to the setup menus or direct keys.
- F2 – MIN Allows full access to the Limits menu and limited access to the Units menu. The Units menu allows selection of either Aeronautical or Pressure units. The units displayed are the default values of the Aeronautical or Pressure units only (see “F1-Units”, 1-3, page 50, for details on configuring the default Aeronautical and Pressure values). The MIN setting also allows programming of the Altitude Correction through SETUP (see ALT / Ps Key Setup”, page 40).
- F3 – FULL Factory default value allowing full access to the SETUP functions.

DPS500/DPS501 INSTRUCTION MANUAL

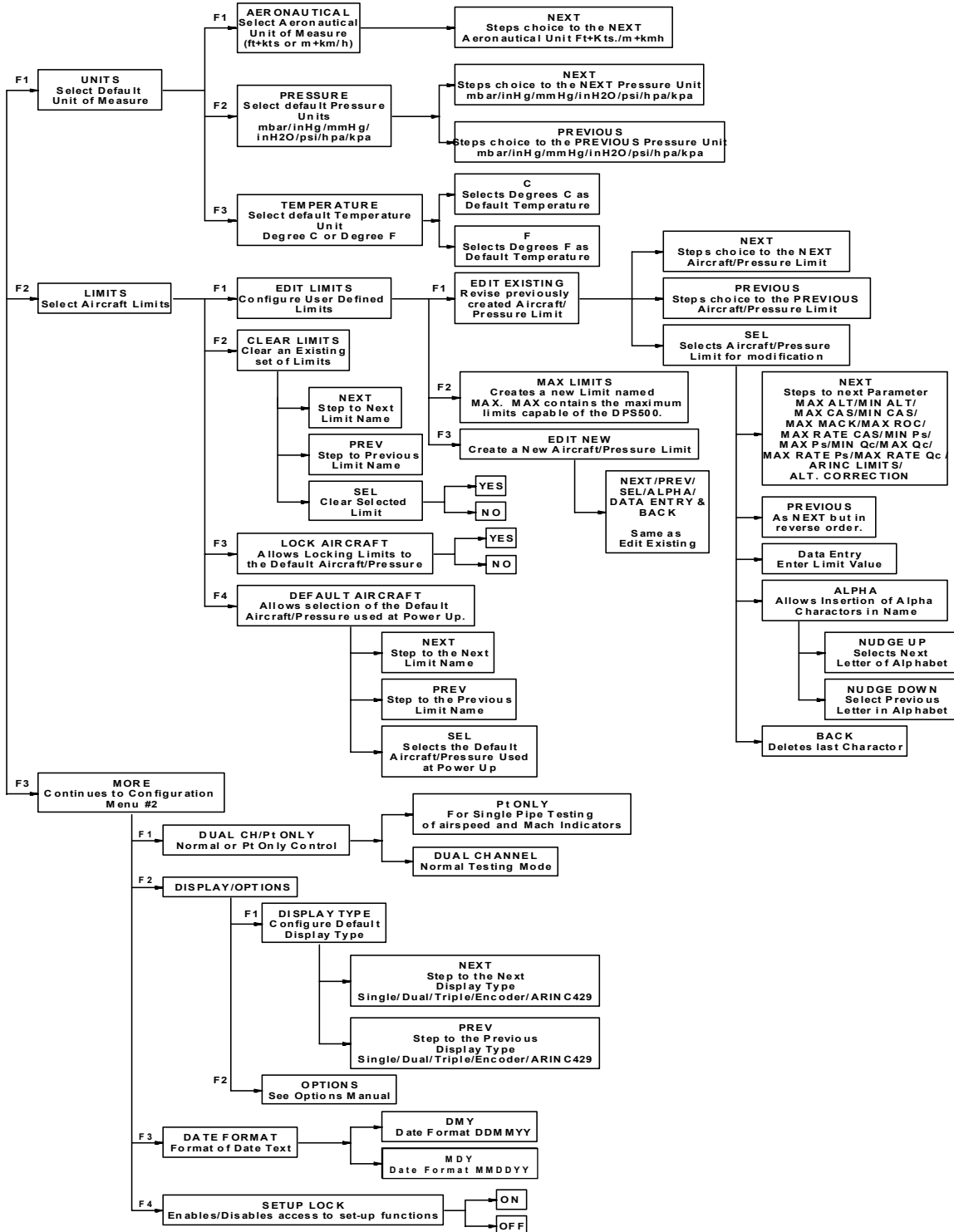

Figure 11 DPS500/501 CONFIG Menu Quick Reference Flowchart

DPS500/DPS501 INSTRUCTION MANUAL

B. DPS500/501 KEY CONFIGURATION

To extend the CONFIG capabilities of the DPS500 / 501, further menus and configuration features are available under certain direct key configurations, as indicated in Figure 12. To access the direct key features of the CONFIG Function of the DPS500/501, press and hold the F1 function key then press the SETUP key on the middle right side of the Remote Handheld Terminal or the lower middle on the Local Key Pad. Once the F1 + SETUP keys have been pressed, CONFIG functions are then available from both the CONFIG menus and directly by pressing certain keys.

For quick reference, a tree diagram of the CONFIG keys is shown in Figure 13, page 70.

Once a parameter has been changed under CONFIG, use CLEAR/QUIT to return to the proceeding menu. After all required parameters have been changed, repeatedly press CLEAR/QUIT until the user display returns.

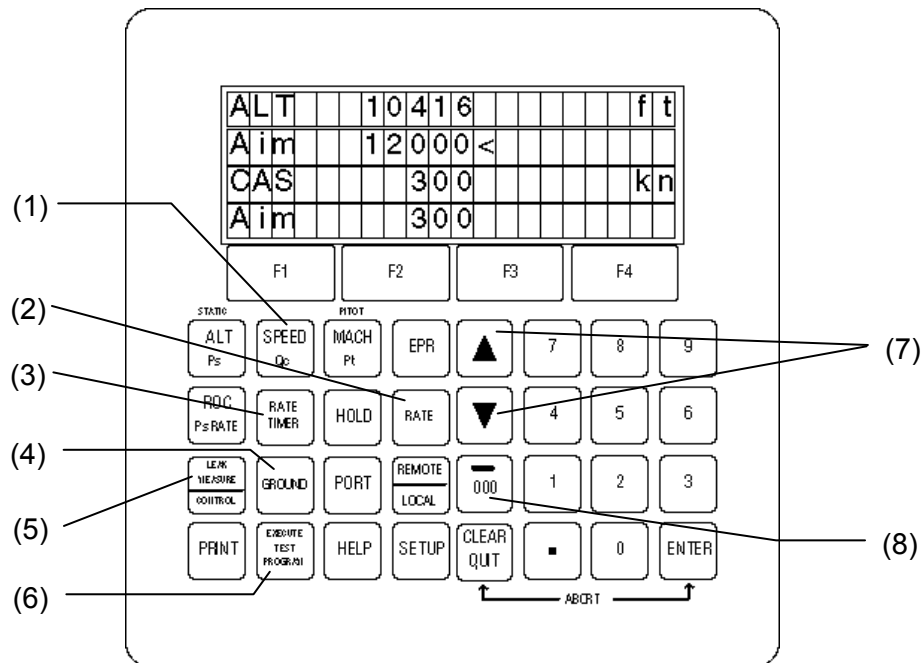

Figure 12 Keys for which the Direct Key CONFIG capability is operational

Note: Keys numbered correspond to paragraphs on pages 64 to 69.

DPS500/DPS501 INSTRUCTION MANUAL

1. SPEED / Qc Key CONFIG

The SPEED / Qc Key CONFIG function allows setting, using the screen shown below, the default values for Auto Zero, CAS / TAS and Pt Temperature settings. The functions available there are as follows:

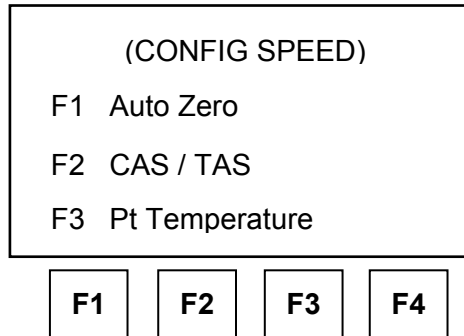

F1 – Auto Zero

CONFIG equivalent of Auto Zero SETUP function, page 39.

F2 – CAS / TAS

CONFIG equivalent of CAS / TAS SETUP function, page 40.

F3 – Pt Temperature

CONFIG equivalent of Pt Temperature SETUP function, page 40.

Note: After a numerical value such as Pt Temperature has been entered via the keyboard the ENTER key must be pressed so the value is accepted by the DPS500/501. If the ENTER key is not pressed the entry will not be saved.

2. RATE Key CONFIG

CONFIG equivalent of Rate Key SETUP function, page 46.

3. RATE TIMER Key CONFIG

CONFIG equivalent of RATE TIMER Key SETUP function, page 41.

4. GROUND Key CONFIG

CONFIG equivalent of GROUND Key SETUP function, page 44.

DPS500/DPS501 INSTRUCTION MANUAL

5. LEAK MEASURE / CONTROL Key CONFIG

The Auto Leak function is a critical safety feature of the DPS500 / 501 designed to automatically protect sensitive pressure instruments from damage caused by excessive leaks.

Auto Limit recovery feature automatically regains control if the pressure on either channel leaks outside of the selected limits.

Using the screen shown below, this function enables or disables the default settings of the AUTO LEAK and AUTO LIMIT recovery facilities and enables the settings to be Locked or Unlocked. Options available from this screen are described as follows. Refer to “LEAK MEASURE / CONTROL Key Setup”, page 42, for further details.

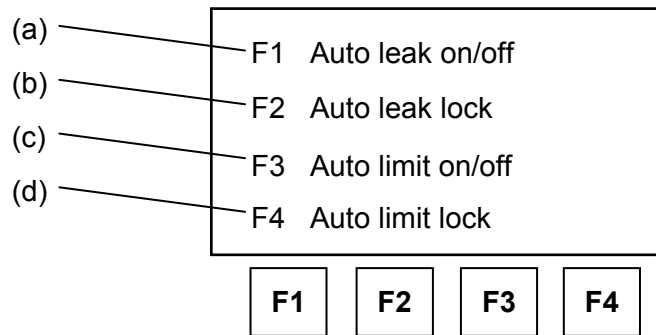

(a) F1 – Auto leak on / off, with the following screen and options:

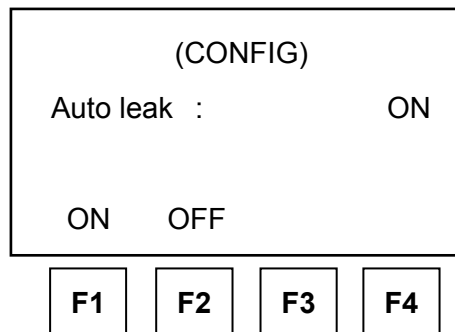

- F1 ON** – When set to ON, the default setting of Auto leak function when test set power is applied is “ON”.
- F2 OFF** – When set to OFF, the default setting of Auto leak function when test set power is applied is “OFF”.

CAUTION: TURNING THE AUTO LEAK FUNCTION OFF IS NOT RECOMMENDED SINCE IT IS A SAFETY FEATURE TO PROTECT SENSITIVE AIRCRAFT SYSTEMS FROM DAMAGE.

DPS500/DPS501 INSTRUCTION MANUAL

(b) F2 – Auto leak lock, with the following screen and options:

(CONFIG)

Auto leak lock : OFF

ON OFF

F1

F2

F3

F4

- F1 ON** – When set to ON, the default setting of Auto leak lock function when test set power is applied is “ON”. This disables the ability to change the Auto leak function status from the SETUP facility.
- F2 OFF** – When set to OFF, the default setting of Auto leak lock function when test set power is applied is “OFF”. This enables the capability of turning the Auto leak function ON or OFF from SETUP facility.

(c) F3 – Auto limit on / off, with the following screen and options:

(CONFIG)

Auto limit on/off : ON

ON OFF

F1

F2

F3

F4

- F1 ON** – When set to ON, the default setting of Auto limit function when test set power is applied is “ON”.
- F2 OFF** – When set to OFF, the default setting of Auto limit function when test set power is applied is “OFF”.

DPS500/DPS501 INSTRUCTION MANUAL

(d) F4 – Auto limit lock, with the following screen and options:

(CONFIG)

Auto limit lock : OFF

ON OFF

F1

F2

F3

F4

- F1 ON** – When set to ON, the default setting of Auto limit lock function when test set power is applied is “ON”. This disables the ability to change the Auto limit function status from the SETUP facility.

- F2 OFF** – When set to OFF, the default setting of Auto limit lock function when test set power is applied is “OFF”. This enables the capability of turning the Auto limit function ON from SETUP facility.

6. EXECUTE TEST PROGRAM Key CONFIG

This function, shown in the screen below, sets up the DPS500/501 for automatically running specific Test Programs or deletion of downloaded test routines saved in memory. Available functions are:

(ETP)

F1 Auto run

F2 Erase programs

F1

F2

F3

F4

- F1 Auto Run** – Default setting for automatically running a test routine upon Power up.

- F2 Erase programs** – Allows selection and erasing of programs downloaded to DPS500/501 memory.

DPS500/DPS501 INSTRUCTION MANUAL

7. NUDGE UP (▲) and NUDGE DOWN (▼) Keys CONFIG

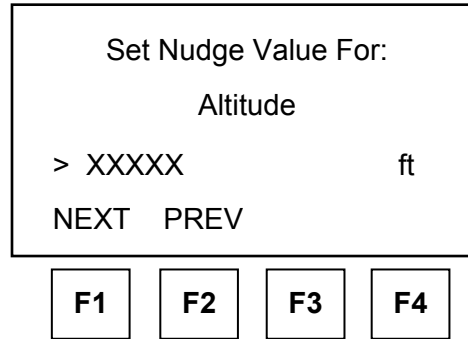

This function allows the default value or authority of the NUDGE key to be set for each of the following parameters:

In aeronautical units, only the aeronautical parameters are available. These are:

ALT ROC CAS / TAS RATE CAS MACH

In pressure units, only the pressure parameters are available. These are:

Ps RATE Ps Pt Qc RATE Qc EPR RATE EPR

When F1 + SETUP then NUDGE is pressed, the display will show the value of NUDGE for the parameter last displayed (i.e. if ALT was the last parameter selected then ALT nudge value would be displayed).

Each parameter is displayed with the current value. Enter a new value to replace the present default value or use the CLEAR / QUIT button to return to the user display.

Note: After a numerical value such as the NUDGE value has been entered via the keyboard the ENTER key must be pressed so the value is accepted by the DPS500/501. If the ENTER key is not pressed the entry will not be saved.

Use F1 [NEXT] or F2 [PREV] to display other parameters.

Press QUIT when the NUDGE values of all required parameters have been changed.

Once a parameter has been changed under CONFIG, use CLEAR / QUIT to return to the proceeding menu. After all required parameters have been changed, repeatedly press CLEAR / QUIT until the user display returns.

DPS500/DPS501 INSTRUCTION MANUAL

8. - / 000 Key CONFIG

This function clears, changes or enters the PIN code that controls access to CONFIG, by displaying the screens shown below.

(SECURITY) Type Old Config PIN >	(SECURITY) Type New Config PIN >
F1 F2 F3 F4	F1 F2 F3 F4

Remarks:

- The prompt may ask for an “Old” or “New” PIN number to be entered.
- If the DPS500 / 501 is currently PIN protected, the “Enter Old Config PIN” will be displayed. If a PIN is in use, this must be entered before it can be changed.
- Upon entry of the Old PIN number, a prompt asks for a New PIN number.
- After entry of the New PIN number, the prompt asks for the new PIN again to protect against data entry errors.
- To clear the PIN, so CONFIG can be entered without a PIN, enter 0000.

DPS500/DPS501 INSTRUCTION MANUAL

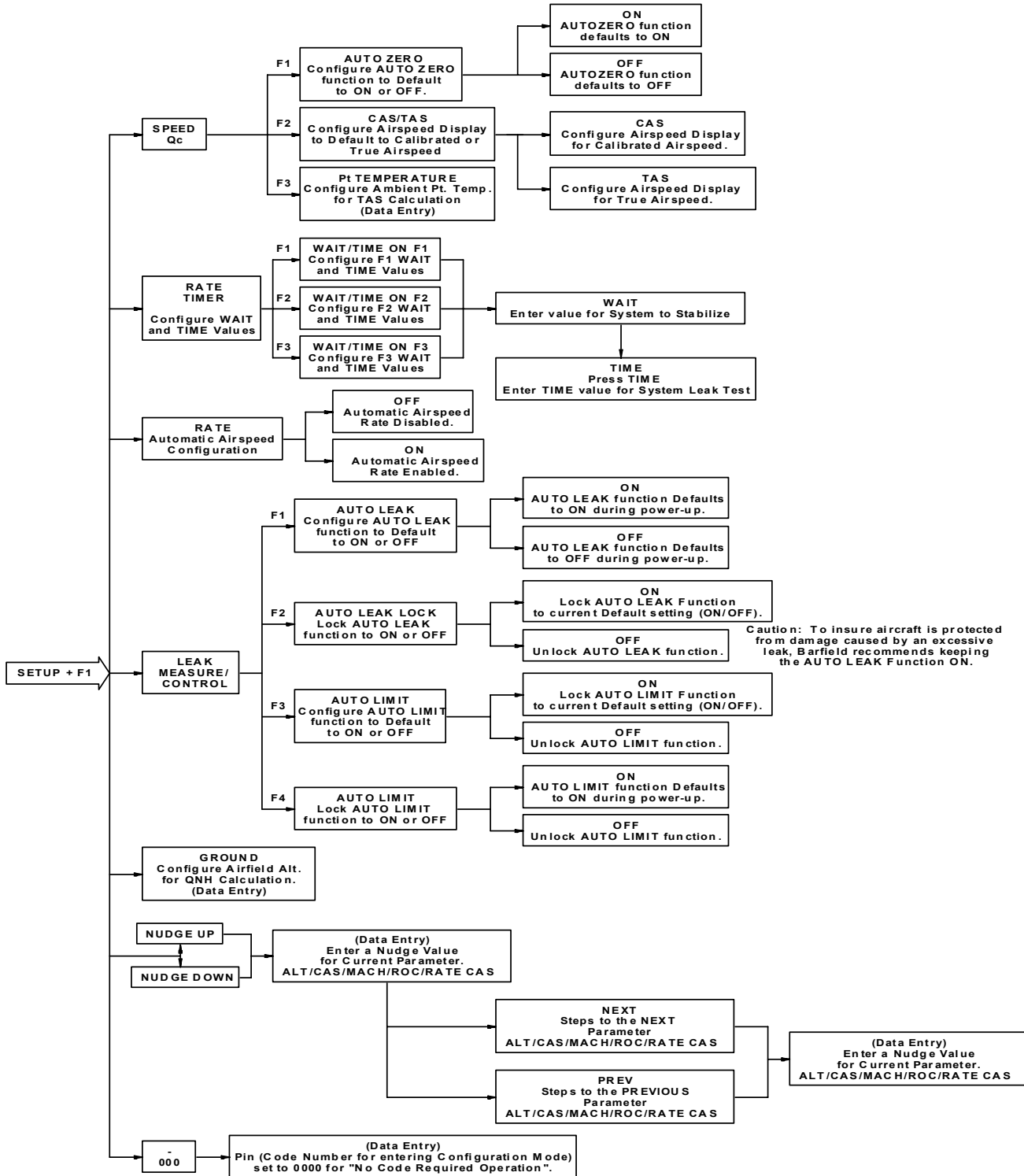

Figure 13 Direct Key Configuration Reference Flowchart

DPS500/DPS501 INSTRUCTION MANUAL

CHAPTER 4: DPS500/501 OPERATION

1. DPS500/501 POWER CONNECTION

A. DPS500 AC ELECTRICAL CONNECTION

1. Ensure that the DPS500 controller and pump power switches (Fig. 14, #5, #4) are in the OFF position prior to connecting the power cable.

Note: The DPS500 flight line power cable supplies electrical power to both the electronics and pump racks.

2. If desired, connect the Remote Handheld Terminal to the DPS500 Controller front panel (marked Hand Terminal) connector using the 2 meter, 18 meter or optional length (100 Ft or 150 Ft) remote cable.

Note: When the Remote Handheld Terminal is connected, the Main (front panel) keypad is automatically disabled.

3. Connect the power cord supplied with the DPS500 to the AC power connector on the Pump assembly (Fig. 14, #2) and to an AC power source (47-440 Hz / 88-260 VAC).

WARNING: THE SUPPLIED POWER MUST PROVIDE CONNECTION TO A PROTECTIVE GROUND TERMINAL. TO PREVENT INADVERTENT INJURY OR DAMAGE TO THE DPS500, THE UNIT MUST, AT ALL TIMES, BE CONNECTED TO THE SUPPLY EARTH (GROUND).

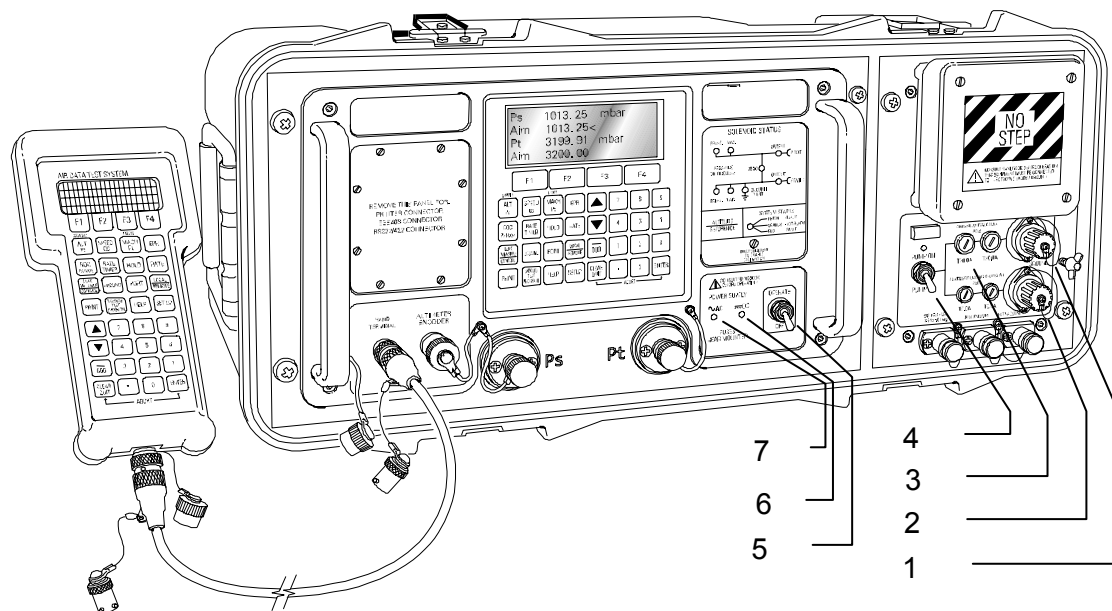

Figure 14 DPS500 Power Connection

DPS500/DPS501 INSTRUCTION MANUAL

4. Verify that the AC Power indicator LED (Fig. 14, #7) is illuminated.
5. If an alternate power cable is used, the power must be supplied by a three core cable installed as follows:

Table 1 DPS500 AC Power Connector Pin-Out

PIN	EUROPEAN COLOR	US COLOR	FUNCTION
1	Brown	Black	Live
4	Blue	White	Neutral
Center	Green / Yellow	Green	Ground

CAUTION: THE POWER SUPPLY CABLE AND CONNECTOR MUST BE CORRECTLY RATED FOR THE POWER SUPPLY.

Note: The Test Set is supplied with a NEMA 5-15P terminated cable, which is a power supply cable approved for use in the U.S.A. for a maximum of 125V AC; it must be replaced by the user if a higher supply voltage is required.

CAUTION: WHEN THE ELECTRICAL POWER IS APPLIED, THE UNIT MUST BE CONNECTED TO THE SUPPLY GROUND AT ALL TIMES.

6. Turn the power switches for the DPS500 Controller (Fig. 14, #5) and the Pump Assembly (Fig. 14, #4) to the ON position. The Pump and Controller do not require to be switched ON in any specific order.

B. DPS500 DC ELECTRICAL CONNECTION (OPTIONAL)

1. The DC power (nominal 28VDC) option on the DPS500, is an alternative power supply utilizing a separate connector.
2. Ensure that the DPS500 controller and pump power switches (Fig. 14, #5, #4) are in the OFF position prior to connecting the power cable.

Note: The DPS500 flight line version power cable supplies both the electronics and pump racks.

3. If desired, connect the Remote Handheld Terminal to the DPS500 front panel (marked Hand Terminal) connector using the 2 meter, 18 meter or optional length (100 Ft or 150 Ft) remote cable.

Note: When the Remote Handheld Terminal is connected, the Main (front panel) keypad is automatically disabled.

4. Connect the power cord supplied with the DPS500 to the DC power connector on the Pump assembly (Fig. 14, #1) and to a DC power source (24-30 VDC).

DPS500/DPS501 INSTRUCTION MANUAL

5. The following is the 28VDC connection breakdown:

Table 2 DPS500 DC Power Connector Pin-Out

PIN	CONNECTION
1	+ 28V
2	0V Return
GND	Ground

6. Verify that the DC Power Indicator LED (Fig. 14, #6) is illuminated.

Note: The DPS500 will not be damaged if both AC Power and DC power are applied at the same time.

7. Turn the power switches for the DPS500 Controller (Fig. 14, #5) and the Pump Assembly (Fig. 14, #4) to the ON position. The Pump and Controller do not require to be switched ON in any specific order.

C. DPS501 CONTROLLER AC ELECTRICAL CONNECTION

1. Ensure that the DPS501 controller power switch (Fig. 15, #3) is in the OFF position prior to connecting the power cable.

Note: When the Remote Handheld Terminal is connected, the Main (front panel) keypad is automatically disabled.

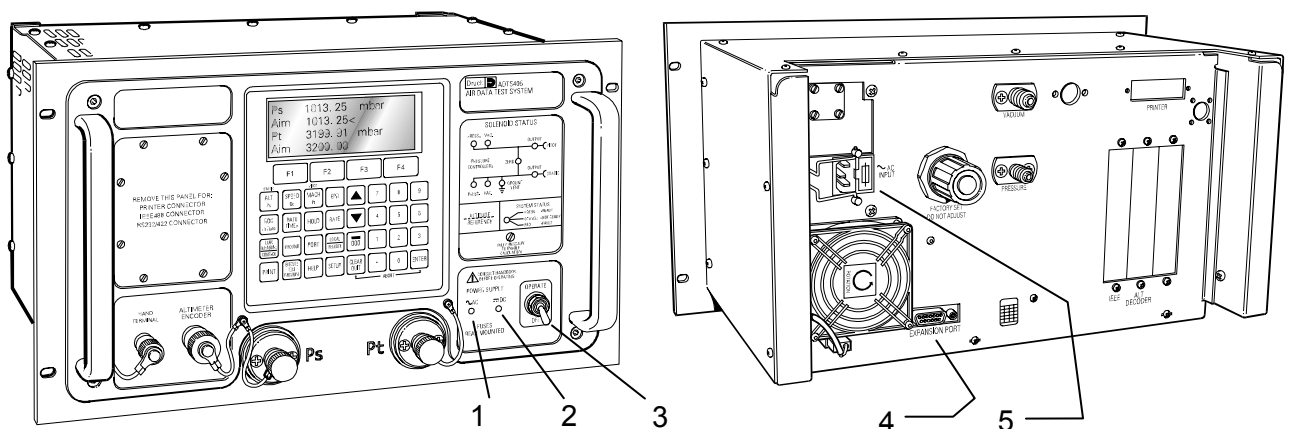

Figure 15 DPS501 Power Connection

DPS500/DPS501 INSTRUCTION MANUAL

2. If desired, connect the Remote Handheld Terminal to the DPS501 Controller front panel (marked Hand Terminal) connector using the 2 meter, 18 meter or optional length (100 Ft or 150 Ft) remote cable.

Note: When the Remote Handheld Terminal is connected, the Main (front panel) keypad is disabled.

3. Connect the standard three pin power cord supplied with the DPS501 to the power receptacle on the rear of the DPS501 (Fig. 15, #5) and to an AC power source (47-440 Hz / 88-260 VAC).

WARNING: THE SUPPLIED POWER MUST ALSO PROVIDE CONNECTION TO A PROTECTIVE GROUND TERMINAL. TO PREVENT INADVERTENT INJURY OR DAMAGE TO THE DPS500, THE UNIT MUST, AT ALL TIMES, BE CONNECTED TO THE SUPPLY EARTH (GROUND).

WARNING: WHEN THE ELECTRICAL POWER IS APPLIED, THE UNIT MUST BE CONNECTED TO THE SUPPLY GROUND AT ALL TIMES.

4. Verify that the AC Power Indicator LED (Fig. 15, #1) is illuminated.
5. Turn the power switch for the DPS501 Controller (Fig. 15, #3) to the ON position.

2. DPS500/501 INITIALIZATION AND SELF-TEST

The DPS500 / 501 contains a built-in self-test and diagnostic system, which continuously monitors the performance of the unit and at power-up carries out a self-test. The following are the procedures for ensuring the DPS500/501 has completed the initialization and self-test correctly.

- A. After power has been applied to the DPS500/501 and pump (DPS500 only), check for the power indicator being ON. During the power-up mode the DPS500/501 will display several messages containing information on the software versions and calibration date of the test set. The first power-up display is as shown below (X represents the version number of the installed software):

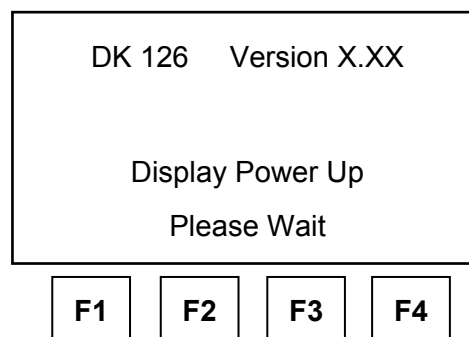

DPS500/DPS501 INSTRUCTION MANUAL

- B. The following power-up display (X represents the version number of the installed software) should follow:

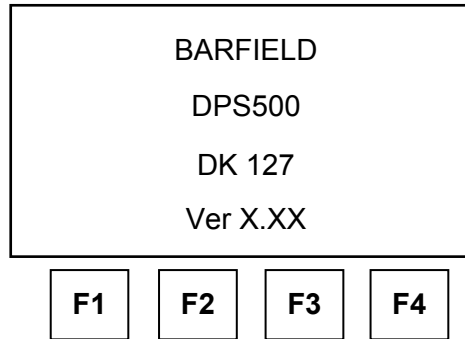

- C. Last Calibration Display

Display gives date when the last calibration was completed. Line three displays the type of transducer contained in the DPS500/501.

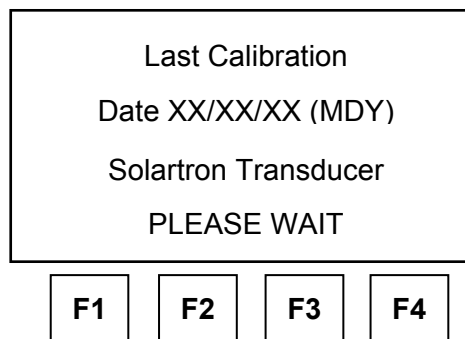

- D. Self-Test

DPS500 / 501 conducts a built-in-test function for automatically detecting internal faults prior to test set operation (see chapter 7, "Troubleshooting", starting on page 103, for error details).

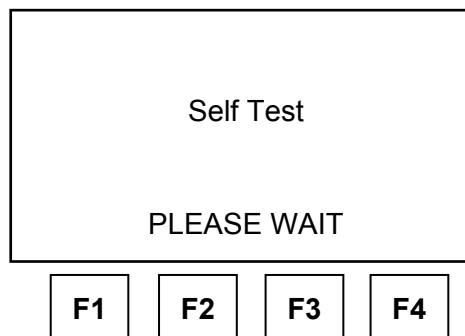

DPS500/DPS501 INSTRUCTION MANUAL

E. Measuring Ground Pressures

The DPS500/501 automatically checks ambient pressure and records it in memory for use when the GO TO GROUND feature is used. The stored pressure value is also used in the calculation and display of QFE and QNH (the solenoid valves will be in the status shown during this function):

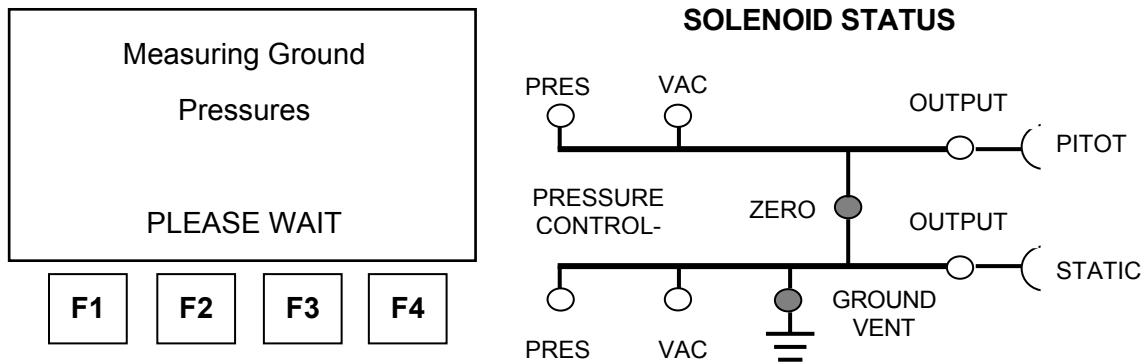

F. Equalizing System Pressures

To prevent pressure surges, the pressures within the aircraft / instrument system, the pressure in the DPS500 / 501 controller and ambient pressure are automatically bled together before venting the system (the solenoid valves will be in the status shown during this function):

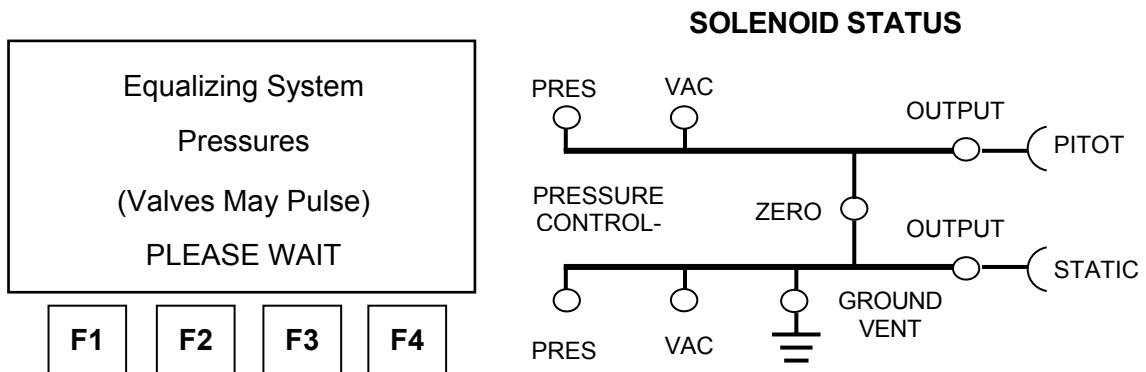

DPS500/DPS501 INSTRUCTION MANUAL

- G. If no faults are detected, the DPS500 / 501 display will transition into the standard Leak Measure (user) display as shown below (the solenoid valves will be in the status shown during this function):

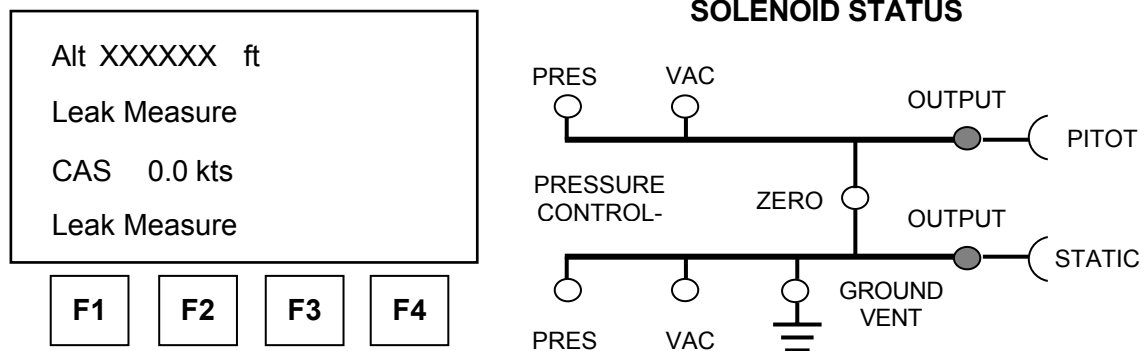

Note: The DPS500/501 always powers up in leak measure mode with the controllers off. In the control mode the pump unit must be switched on and producing the correct pressure and vacuum.

3. DPS500/501 LEAK TESTING

Each test set is completely calibrated and tested before shipment; however, to ensure the integrity of the tests, *the tester should be leak checked before each use*. Therefore, a 10,000 Ft and 300 Knots leak test is recommended. The following is the procedure for accomplishing this leak test:

1. Install DPS500/501 Ps and Pt output port caps or connect hoses with capped ends.

Note: Due to a very limited volume contained in the DPS500 / 501 with the output ports capped, the unit should be leak tested with hoses attached to increase the volume. If the DPS500 / 501 is leak tested with the output ports capped, wait at least 5 minutes for the unit pressures to stabilize after attaining the altitude and airspeed. Leak tests performed immediately after attaining the desired pressure may result in erroneous values caused by temperature effects.

2. Procedures for attaining the 10,000 Ft and 300 Knot pressures.
 - (a) Select the LEAK MEASURE / CONTROL key to toggle the DPS500 / 501 into the "Control" mode.
 - (b) Press the ROC key to set the units vertical speed.
 - (c) Select 6000 and press ENTER.
 - (d) Press the ALT / Ps key to set the altitude for the leak test.
 - (e) Select 10000 and press ENTER.
 - (f) Press the SPEED / Qc key to set the airspeed for the leak test.



DPS500/DPS501 INSTRUCTION MANUAL

(g) Select 300 and press ENTER.

Upon entering the test points, the test set will begin moving towards the values entered. When the test set has attained the necessary Altitude and Airspeed, perform the Leak Test procedure described in the subsection immediately below.

3. Leak Testing the DPS500/501:

- (a) Select the LEAK MEASURE / CONTROL key to toggle the DPS500 / 501 into the "Leak Measure" mode.
- (b) Press the RATE TIMER key.
- (c) Select F3 ("05:00" Wait and "01:00" Time).
- (d) After the test set pressures settle for 5 min., the unit automatically performs a 1 min. leak test and will display the leak test results. The test set leak should not exceed 20 ft/min or 2 knot/min.

4. Returning the DPS500/501 to ground Pressure:

- (a) If the display shows "LEAK MEASURE", select the LEAK MEASURE / CONTROL key to toggle the DPS500/501 into the "Control" mode.
- (b) Press the GROUND key.
- (c) Select F1 "Go To Ground".
- (d) The pressure in the system will begin to move towards Ground or ambient pressure at the vertical speed (ROC) specified.
- (e) If necessary, a new airspeed rate or altitude VSI can be entered during the GO TO GROUND function by selecting ROC or RATE and entering the new vertical speed or airspeed rate.
- (f) To interrupt the Go To Ground function and enter a new test point can be accomplished two ways:

Press the HOLD key to stop the altitude and airspeed at its current pressure value. At this time, any aeronautical parameter (ALT, CAS, ROC etc.) may be changed while the pressures are on hold. Pressing the HOLD key again restarts the pressure changes (this is, allow the altitude and airspeed to begin changing) toward the new pressure values.

Or,

Press the ALT / Ps key to change the altitude or the SPEED / Qc key to change the airspeed value. During this operation the altitude and airspeed continue to move towards ground and zero respectively until the new value is entered. Upon pressing the ENTER key and acceptance by the DPS500 / 501 (this is, limit protection verification), the pressure will then move towards the new value.

The DPS500/501 Leak Test is complete.

DPS500/DPS501 INSTRUCTION MANUAL

4. DPS500/501 PNEUMATIC PRESSURE CONNECTION

A. DPS500 FLIGHTLINE TEST SET CONNECTION

Ps Output	-	MS33656-6 (Fig. 16, #1)
Pt Output	-	MS33656-4 (Fig. 16, #2)
External Pressure Supply	-	MS33656-4 (Fig. 16, #3)
Auxiliary Vacuum Supply	-	MS33656-4 (Fig. 16, #4)
External Vacuum Supply	-	MS33656-6 (Fig. 16, #5)

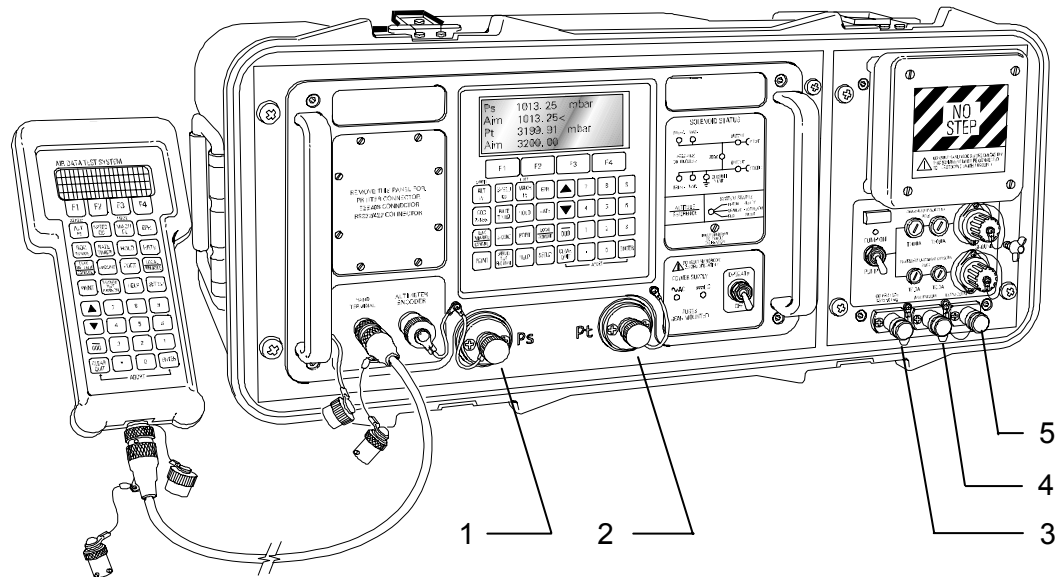

Figure 16 DPS500 Pneumatic Pressure Connections

1. During normal operation make sure that the correct blanking caps (Fig. 16, #3, #4, #5) are snugly fitted to the external connectors.

Note: A leak of the external pressure / vacuum blanking caps (Fig. 16, #3, #4, #5) can affect the performance of the DPS500.

2. The external pressure and vacuum connections on the pump unit are used when an external pressure and / or vacuum source is used. The pressure / vacuum supply should be clean, dry air (refer to “Pressure Media” specification, page 23). Using an external pressure source / sources may change the DPS500 maximum achievable altitude / airspeed / rate specifications.
3. Connect the Unit Under Test (UUT) to the front Ps output (Fig. 16, #1) and Pt output (Fig. 16, #2) connectors.
4. For single channel testing of Altimeters or similar, requiring only Ps, connect the UUT to Ps output (Fig. 16, #1) and fit the blanking cap on the Pt. output (Fig. 16, #2).

DPS500/DPS501 INSTRUCTION MANUAL

5. For single channel testing of Airspeed Indicators or similar, requiring only Pt, connect the UUT to Pt output (Fig. 16, #2). The Ps output (Fig. 16, #1) must be left open to atmosphere (no blanking cap) to provide a reference pressure.

WARNING: ENSURE THE DPS500 Pt CHANNEL IS CONNECTED TO THE AIRCRAFT PITOT SYSTEM OR INSTRUMENT PITOT PORT, AND THAT THE AIRCRAFT STATIC SYSTEM OR INSTRUMENT STATIC PORT IS OPEN TO AMBIENT PRESSURE. OTHERWISE AIRCRAFT / INSTRUMENT DAMAGE MAY OCCUR.

Note: The Pt ONLY mode of operation should be used.

B. DPS501 DUAL CHANNEL CONTROLLER CONNECTION

Ps Output	-	MS33656-6 (Fig. 17, #1)
Pt Output	-	MS33656-4 (Fig. 17, #2)
Pressure Input	-	MS33656-4 (Fig. 17, #3)
Vacuum Input	-	MS33656-4 (Fig. 17, #4)

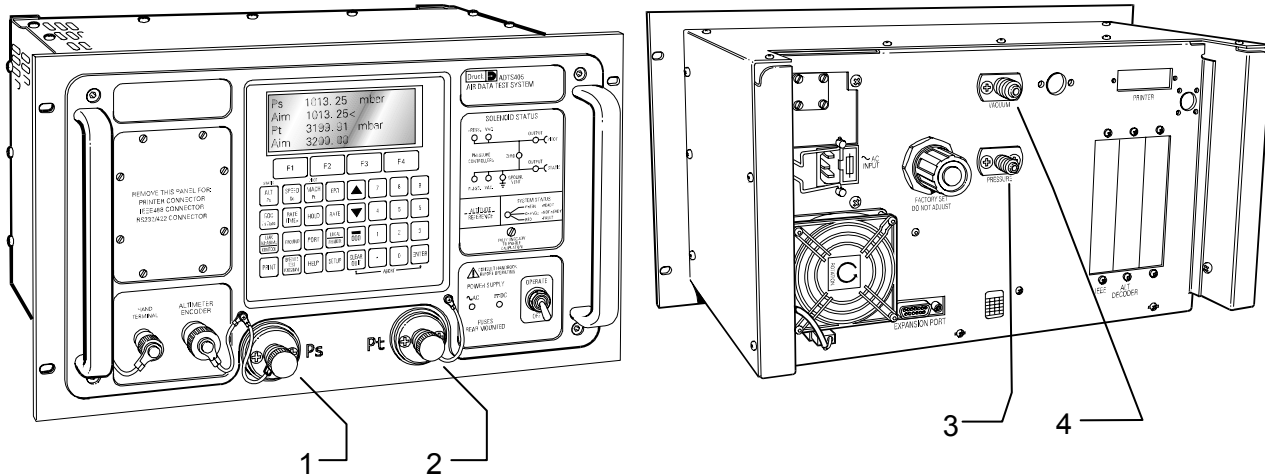

Figure 17 DPS501 Pneumatic Pressure Connections

1. Connect the pressure and vacuum supplies to the rear panel PRESSURE input (Fig. 17, #3) and VACUUM input (Fig. 17, #4) connectors. The pressure supply should be clean, dry air (refer to “Pressure Media” specification, page 23).
2. Connect the Unit Under Test (UUT) to either the front or rear (Option) Ps output (Fig. 17, #1) and Pt output (Fig. 17, #2) connectors.

Note: Blanking caps must be fitted on unused front or rear outputs.

DPS500/DPS501 INSTRUCTION MANUAL

3. For single channel testing of Altimeters or similar, requiring only Ps, connect the UUT to Ps output (Fig. 17, #1) and fit the blanking cap on Pt output (Fig. 17, #2).
4. For single channel testing of Airspeed Indicators or similar, requiring only Pt, connect the UUT to Pt output (Fig. 17, #2). The Ps output (Fig. 17, #1) must be left open to atmosphere (no blanking cap) to provide a reference pressure.

WARNING: ENSURE THE DPS501 Pt CHANNEL IS CONNECTED TO THE AIRCRAFT PITOT SYSTEM OR INSTRUMENT PITOT PORT, AND THAT THE AIRCRAFT STATIC SYSTEM OR INSTRUMENT STATIC PORT IS OPEN TO AMBIENT PRESSURE. OTHERWISE AIRCRAFT / INSTRUMENT DAMAGE MAY OCCUR.

Note: The Pt ONLY mode of operation must be used.

5. PHYSICAL POSITIONING

In order to insure the most accurate testing conditions possible, the DPS500/501 Air Data Test Sets are equipped with a feature called "Altitude Correction". Due to the position (altitude) of the test set relative to the Aircraft or Instrument position (illustrated in figures 18 and 19 on next page) a direct error may be introduced into the test. When the DPS500 / 501 is correctly configured and setup, the Altitude Correction feature of the test set removes this error.

A. MANUAL ALTITUDE CORRECTION SETUP

The following steps describe the step-by-step process for entering or adjusting an altitude correction value:

1. Determine the distance rounded to the nearest foot between the reference line on the DPS501/500 (see Figure 4, Item (12), on Page 6) and the pressure reference line for the aircraft or the instrument under test. Examples of this distance are shown in Figures 19 and 20 on the next page.
2. Press SETUP key.
3. Press the ALT / Ps key.
4. Enter the distance between the test set and the aircraft / instrument reference points and press the ENTER key. (This value is lost after DPS500/501 is turned OFF).

Note: If the DPS500/501 Test Set is above the Aircraft reference point, the Altitude Correction will be a negative value.

DPS500/DPS501 INSTRUCTION MANUAL

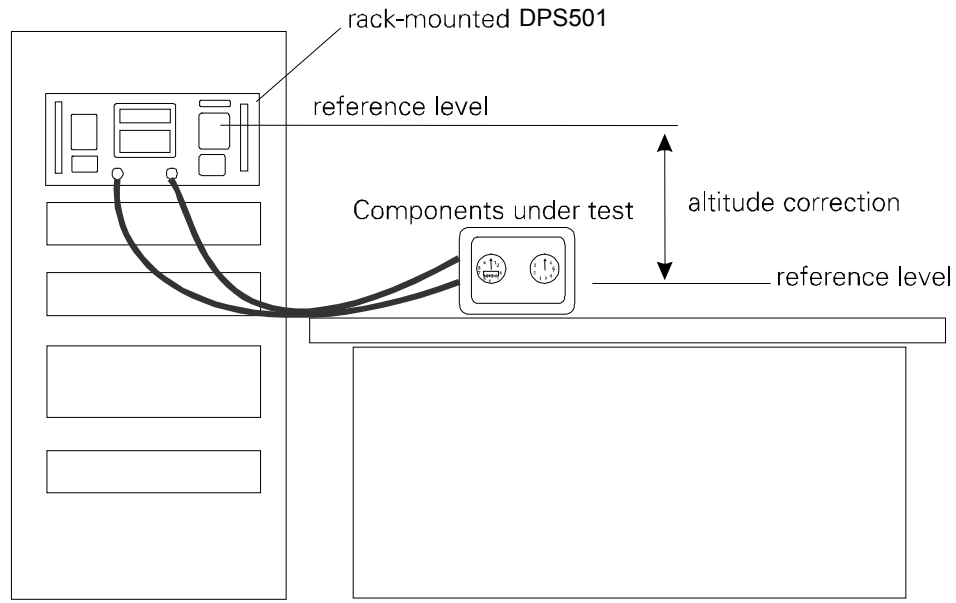

Figure 18 DPS501 Altitude Reference

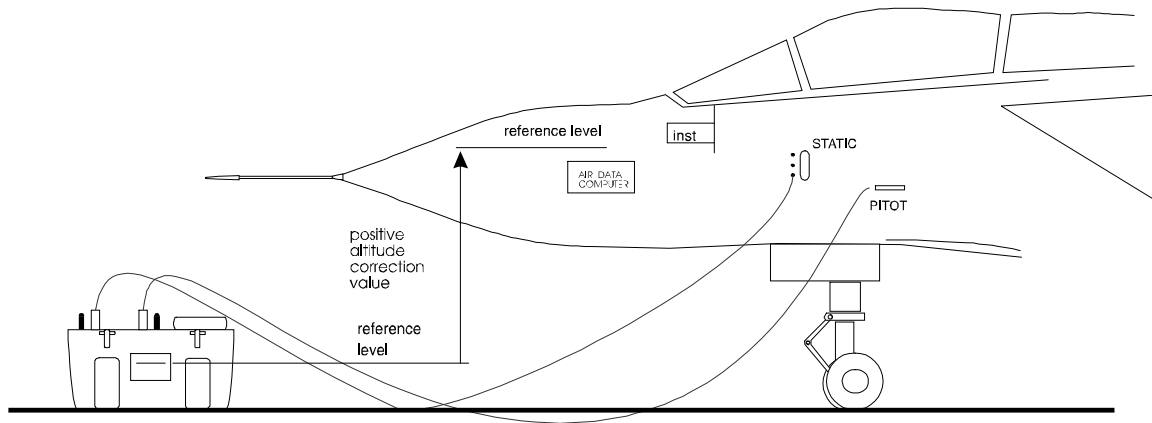

Figure 19 DPS500 Altitude Reference

DPS500/DPS501 INSTRUCTION MANUAL

B. ALTITUDE CORRECTION THROUGH LIMIT SETUP

One of the data cells contained in the Aircraft Limits database can be used for setting the Altitude Correction value (see “ALT / Ps Key Setup”, page 40, for details) unique to the specific aircraft selected. If the Aircraft Limits database in the DPS500 / 501 has been properly setup (see “Limits”, page 53 for details), Altitude Correction will be set simply by selecting the aircraft being tested from the Aircraft Limit database. Follow the instructions on the next page for selecting an aircraft from the Aircraft Limits database.

To verify the current Altitude Correction value, proceed as follows:

1. Press SETUP key.
2. Press the ALT / Ps key.
3. Verify the distance between the test set and the aircraft / instrument reference points is correct. Change Altitude Correction value as necessary.

Note: If the DPS500/501 Test Set is above the Aircraft reference point, the Altitude Correction will be a negative value.

6. DPS500/501 LIMIT PROTECTION SETUP

If the DPS500 / 501 is configured correctly (see “Limits”, page 53, for guidance on Aircraft Limits programming), the user will be able to select from an Aircraft Limits database.

1. Ensure the DPS500/501 is in the LEAK MEASURE mode.

Note: The Aircraft Limits can only be changed when the DPS500 / 501 is in the LEAK MEASURE mode. If the DPS500/501 is in the CONTROL mode then the following message will be displayed:

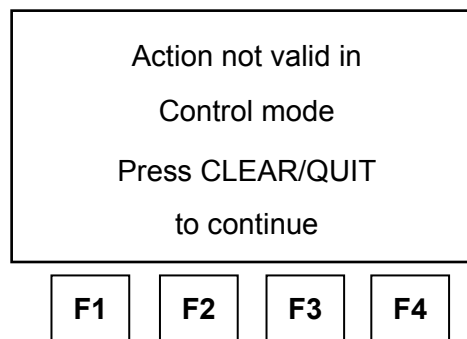

2. Press SETUP key.
3. Press F2 “LIMITS”.

DPS500/DPS501 INSTRUCTION MANUAL

4. Press F1 “NEXT” or F2 “PREV” to find the aircraft being tested.

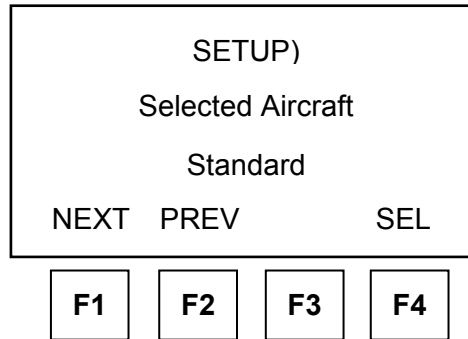

Note: The Aircraft Limits database consists of user-programmed values. The DPS500/501 must be properly programmed for the aircraft type maintained by user prior to maintenance action. If the aircraft being tested is not present in the database, see “Limits”, page 53, for guidance on Aircraft Limits programming.

5. The following are the values found in the factory programmed limits:

CIVIL is a factory-programmed limit with the following Aeronautical Limits:

Max. Altitude = 50,000 ft	Min. Altitude = -1000 ft	Max. CAS = 450 knots
Min. CAS = 0.0 knots	Max. Mach = 1.000	Max. ROC = 6,000 ft/min
Max Rate CAS = 600 knots/min	Altitude Correction = 0 ft	

STANDARD is a factory-programmed limit with the following Aeronautical Limits:

Max. Altitude = 80,000 ft	Min. Altitude = -2000 ft	Max. CAS = 850 knots
Min. CAS = 0 knots	Max. Mach = 2.50	Max. ROC = 9,000 ft/min
Max. Rate CAS = 600 knots/min	Altitude Correction = 0 ft	

CAUTION: DUE TO “STANDARD” HAVING HIGHER LIMITS THAN SPECIFIED FOR MOST CIVIL AIRCRAFT, THE “STANDARD” LIMITS SETTING ON THE DPS500/501 IS NOT RECOMMENDED FOR CONTINUOUS USE WHILE CONNECTED TO AN AIRCRAFT. (SEE LIMITS, PAGE 53, FOR GUIDANCE ON AIRCRAFT LIMITS PROGRAMMING)

MAX is a factory-programmed limit with the following Aeronautical Limits:

Max. Altitude = 105,000 ft	Min. Altitude = -3000 ft	Max. CAS = 850 knots
Min. CAS = -100.0 knots	Max. Mach = 12.350	Max. ROC = 100,000 ft/min
Max. Rate CAS = 2000 knots/min	Altitude Correction = 0 ft	

CAUTION: DUE TO THE VERY HIGH LIMITS, THE MAX LIMITS SETTING ON THE DPS500 / 501 SHOULD NOT BE USED WHILE CONNECTED TO AN AIRCRAFT.

DPS500/DPS501 INSTRUCTION MANUAL

5. When the applicable aircraft has been found Press F4 “SEL” to select.
6. The display will return to the main Menu.

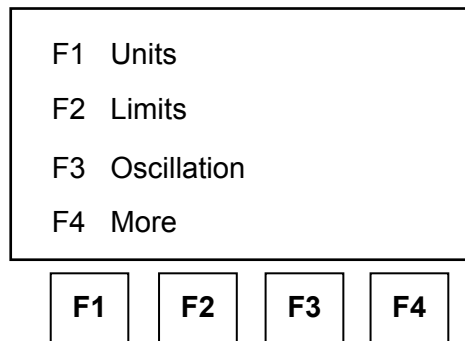

7. Press “CLEAR / QUIT” to return to the user display.
8. The display should have an A/C symbol on the bottom right hand corner of the display.

Note: When power is first applied to the DPS500/501, “WARMUP” will be displayed for 15 min. in place of the A/C symbol. The A/C symbol indicates that the aeronautical or pressure value displayed includes an Altitude Correction adjusted value.

7. DPS500/501 AIRCRAFT LEAK TESTING

Note: This Aircraft Leak Test section is an example of how to conduct a Leak Test with the DPS500/501 and should not be used in place of the procedures outlined by the aircraft manufacturer.

A. SELECT AIRCRAFT LIMITS

Ensure the proper Aircraft Limits have been selected (refer to page 83).

B. ATTAINING TEST ALTITUDE AND AIRSPEED

Procedure for attaining the desired altitude and airspeed to perform an aircraft leak test:

1. If the display shows “LEAK MEASURE”, select the LEAK MEASURE / CONTROL key to toggle the DPS500/501 into the “Control” mode.
2. Press the SPEED / Qc key to set the leak test Airspeed.
3. Enter the desired Airspeed value (for example, 300) and press ENTER.
4. The test set and aircraft will begin moving towards the airspeed entered.

DPS500/DPS501 INSTRUCTION MANUAL

5. Press the ROC key to set the Vertical Speed (factory default value is 3000 ft/min).
6. Enter the desired Vertical Speed value (for example, 6000) and press ENTER.
7. Press the ALT / Ps key to set the leak test Altitude.
8. Enter the desired Altitude value (for example, 10000) and press ENTER
9. The test set and aircraft will begin moving towards this altitude at the VSI rate entered previously.

Note: The DPS500/501 is capable of conducting a combined pitot and static test (as described above) or individual system leak tests. To accomplish a single channel (Pitot only or Static only) modify the procedures by skipping the unnecessary procedures.

Note: When Altitude and Airspeed are changing at the same time, the system automatically adjusts the airspeed rate so that the aim points are reached at the same time. The airspeed rate may be lower then, but will not exceed the entered aim value. This feature is called Automatic Airspeed, and can be temporarily disabled by following the procedure for Rate Key Setup (page 46).

10. When the test set has attained the necessary Altitude and / or Airspeed, perform the leak test procedure in the next section.

C. AIRCRAFT LEAK TESTING

1. Procedures for performing the aircraft leak test.
 - (a) Select the LEAK MEASURE / CONTROL key to toggle the DPS500/501 into the "Leak Measure" mode.
 - (b) Press the RATE TIMER key.
 - (c) Select F1, F2 or F3 to select the Wait and Test Times.

Note: The Wait and Time periods can be changed following the procedures outlined in "RATE TIMER Key Setup", beginning on page 41.

- (d) After the test set has waited or stabilized for the specified WAIT time, the unit automatically performs a leak test equal to the TIME value selected and then displays the leak test results.
2. Returning the DPS500/501 to ground Pressure:
 - (a) Select the LEAK MEASURE / CONTROL key to toggle the DPS500/501 into the "Control" mode.
 - (b) Press the GROUND key.

DPS500/DPS501 INSTRUCTION MANUAL

- (c) Select F1 "Go To Ground".
 - (d) The unit will automatically return the pressures to ambient pressure.
3. When Ground (ambient pressure) and zero airspeed have been achieved and all testing completed, disconnect the DPS500/501 from the aircraft or instrument under test.

8. DPS500/501 AIRCRAFT TESTING

The user should become familiar with the DPS500/501 Test Set as described in the earlier chapters before attempting any tests. The procedures described herein are not intended to replace any specifications by either the airframe or instrument manufacturer. *The user should give particular attention to generating a full aircraft limits database containing one of each aircraft maintained (see information about "Limits", starting on page 53).*

Note: The term "ambient" will occur frequently in these instructions. It refers to the current atmospheric pressure in the area where the test is being performed.

A. PRELIMINARY STEPS

1. Power Connection
Follow the power connection instructions beginning on page 71.
2. DPS500/501 Leak Test
Ensure the DPS500 / 501 has completed a Leak Test following the instructions beginning on page 77.
3. Pneumatic Connection
Follow pneumatic connection instructions beginning on page 79.
4. DPS500/501 Physical Position
The DPS500 / 501 should be placed in a standard position (this is, floor, cart, etc.) during each use on an aircraft or instrument (see information regarding Physical Positioning, starting on page 81, for further details).

B. TYPICAL OPERATION

1. If the display shows "LEAK MEASURE", select the LEAK MEASURE / CONTROL key to toggle the DPS500/501 into the "Control" mode.
2. Press the SPEED / Qc key to set the leak test Airspeed.
3. Enter the desired Airspeed value (for example, 300) and press ENTER.

DPS500/DPS501 INSTRUCTION MANUAL

4. The test set and aircraft will begin moving towards the airspeed entered.
5. Press the ROC key to set the Vertical Speed (factory default value is 3000 ft/min).
6. Enter the desired Vertical Speed value (for example, 6000) and press ENTER.
7. Press the ALT/Ps key to set the leak test Altitude.
8. Enter the desired Altitude value (for example, 10000) and press ENTER.
9. The test set and aircraft will begin moving towards this altitude at the VSI rate entered previously.

Note: The DPS500/501 is capable of conducting a combined Pitot and Static test (as described above) or individual system leak tests. To accomplish a single channel (Pitot only or Static only) modify the procedures by skipping the unnecessary procedures.

Note: When Altitude and Airspeed are changing at the same time, the system automatically adjusts the airspeed rate so that the aim points are reached at the same time. The airspeed rate may be lower then, but will not exceed the entered aim value. This feature is called Automatic Airspeed and can be temporarily disabled by following the procedure for Rate Key Setup (page 46).

10. When the test set has attained the necessary Altitude and/or Airspeed wait at least 10 seconds for the pressures to stabilize. Repeat steps (2) through (10) for any additional test points.
11. Returning the DPS500/501 to ground Pressure:
 - (a) If the display shows “LEAK MEASURE”, select the LEAK MEASURE / CONTROL key to toggle the DPS500/501 into the “Control” mode.
 - (b) Press the GROUND key.
 - (c) Select F1 “Go To Ground”.
 - (d) The unit will automatically return the pressures to ambient pressure and vent system.
12. When Ground (ambient pressure) and zero airspeed have been achieved and all testing completed, disconnect the DPS500/501 from the aircraft or instrument under test. When the test set has vented the system and it is safe to disconnect the aircraft or instrument, the following display will appear:

DPS500/DPS501 INSTRUCTION MANUAL

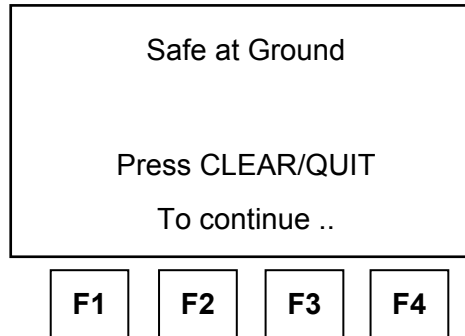

C. QUICK OPERATION USING NUDGE KEYS

1. This is an alternate and much quicker way of operating the DPS500/501 during tests similar to the FAR 91.411 Altimeter System and Altitude Reporting Equipment Test or FAR 43 Appendix E, Altimeter System Test and Inspections. These certifications have test points in set increments so the nudge keys could be used to expedite the testing. Tests using the aeronautical units; ALT, ROC, CAS / TAS, MACH, RATE CAS or any of the available pressure units can also use this function for their applicable tests.
2. The following instructions show an example of how to use the SETUP key to program the nudge key for simplifying Altimeter testing.
 - (a) Press the SETUP key.
 - (b) Press the Nudge Up (\blacktriangle) key or Nudge Down (\blacktriangledown) key.
 - (c) When SETUP then NUDGE is pressed, the display will show the current value of the NUDGE for the parameter last displayed (for example, if ALT was the last parameter selected then ALT nudge value would be displayed). The following display will appear:

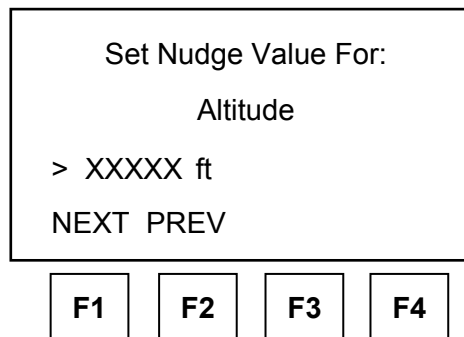

DPS500/DPS501 INSTRUCTION MANUAL

- (d) Each parameter is displayed with the current value. To set the nudge keys for 500 ft, press F1 or F2 PREV until the nudge value for Altitude is displayed. Enter 500 to set the nudge value at 500 ft and press ENTER. Press the CLEAR / QUIT button to return to the user display.

Note: After a numerical value such as the Nudge value has been entered via the keyboard, the ENTER key must be pressed so the value is accepted by the DPS500/501. If the ENTER key is not pressed the entry will not be saved.

3. If the display shows "LEAK MEASURE", select the LEAK MEASURE / CONTROL key to toggle the DPS500/501 into the "Control" mode.
4. Press the ROC key to set the Vertical Speed (factory default value is 3000 ft/min).
5. Enter the desired Vertical Speed value (for example, 6000) and press ENTER.
6. Press the ALT / Ps key to set the first Altitude test point.
7. Enter the first test point (for example, 1000) and press ENTER
8. The test set and aircraft will begin moving towards this altitude at the VSI rate entered previously.
9. When the test set has attained the necessary Altitude allow at least 10 seconds for the pressures to stabilize.
10. If, for example, the next test point is at 0 ft.
 - (a) Press the Nudge Up (▲) key once. The altitude Aim will change to -500 ft.
 - (b) The second time the Nudge Up (▲) is pressed will set the altitude Aim to 0 ft.
11. The Nudge Up (▲) key can be used to increase the altitude by 500 ft and the Nudge Down (▼) key to decrease the altitude by 500 ft for any additional test points.
12. Returning the DPS500/501 to ground Pressure:
 - (a) If the display shows "LEAK MEASURE", select the LEAK MEASURE / CONTROL key to toggle the DPS500/501 into the "Control" mode.
 - (b) Press the GROUND key.
 - (c) Select F1 "Go To Ground".
 - (d) The unit will automatically return the pressures to ambient pressure.
13. When Ground (ambient pressure) and zero airspeed have been achieved and all testing completed, disconnect the DPS500/501 from the aircraft or instrument under test. When the test set has vented the system and it is safe to disconnect the aircraft or instrument, the display shown on the next page will appear.

DPS500/DPS501 INSTRUCTION MANUAL

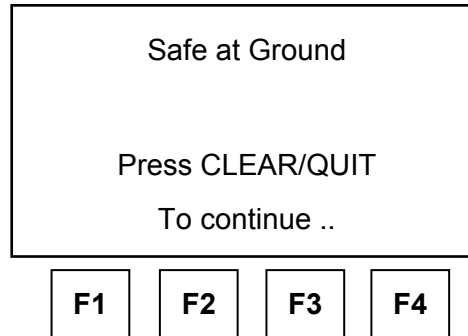

D. MACH TEST AND CONSTANT MACH

1. If the display shows “LEAK MEASURE”, select the LEAK MEASURE / CONTROL key to toggle the DPS500/501 into the “Control” mode.
2. Press the RATE to set an Airspeed rate of change.
3. Enter the desired Airspeed rate of change value (for example, 300 kts/min) and press ENTER.
4. Press the MACH key to set the Mach airspeed.
5. Enter the desired Mach value (for example, 0.7) and press ENTER.
6. The test set and aircraft pitot pressure will begin moving towards the set Mach value entered previously.
7. When the test set has attained the requested Mach, allow approximately 10 seconds for the pressures to stabilize. Repeat steps (4) through (6) for any additional test points.

Note: The DPS500/501 Nudge function can also be used to adjust for other Mach test point values (see “Quick Operation Using Nudge Keys”, page 89).

8. Returning the DPS500/501 to ground Pressure:
 - (a) Select the LEAK MEASURE / CONTROL key to toggle the DPS500/501 into the “Control” mode.
 - (b) Press the GROUND key.
 - (c) Select F1 “Go To Ground”.
 - (d) The unit will automatically return the pressures to ambient pressure.
9. When Ground (ambient pressure) and zero airspeed have been achieved and all testing completed, disconnect the DPS500/501 from the aircraft or instrument under test.

DPS500/DPS501 INSTRUCTION MANUAL

E. TRUE AIRSPEED TESTING

1. The normal airspeed parameter is Calibrated Airspeed (CAS) (equivalent to Indicated Airspeed for testing purposes).
2. The airspeed parameter may be changed to True Airspeed (TAS) as follows:
 - (a) Press the SETUP key.
 - (b) Press the SPEED / Qc key.
 - (c) Press the F2 "CAS / TAS" key.
 - (d) Select TAS.
 - (e) Press CLEAR / QUIT once to return to the (SETUP SPEED) menu.
 - (f) Press the F3 "Pt Temperature" key.

Note: Pitot temperature is used in the calculation of TAS. This value must be correctly entered or the TAS airspeed displayed will be inaccurate.
 - (g) Type in the temperature measured by the aircraft's Pitot temperature sensor and press ENTER.

Note: The Pitot temperature must be entered in the displayed units ($^{\circ}\text{C}$ or $^{\circ}\text{F}$) (see page 52 for details on changing the temperature unit).
 - (h) Press CLEAR / QUIT three times to return to the user display.
3. Use the procedure for TYPICAL OPERATION on page 87, but substitute TAS in for all entries for CAS.

F. ENGINE PRESSURE RATIO (EPR) TESTING

1. The DPS500 / 501 may be used to check EPR sensors and indicators. Use Ps for INLET PRESSURE and Pt for OUTLET pressure.
2. To carry out an EPR check, the display must be showing pressure units e.g. mbar or inHg.
3. Use the "Units" Setup procedure described on page 27 to change the unit of measure.
4. The following procedures describe the operation to perform a test having an EPR of 1.8 and an inlet pressure on 500 mbar (or 15 inHg).
 - (a) Press the ROC / Ps RATE key to set the rate of change for the static channel.
 - (b) Type in the desired static rate of change e.g. 1000 mbar/min, (30 inHg/min) and press ENTER.
 - (c) Press the EPR then RATE key to set the EPR rate.

DPS500/DPS501 INSTRUCTION MANUAL

(d) Type in the desired EPR rate of change e.g. 5 EPR/min and press ENTER.

Note: To achieve an EPR rate of above 0.1 EPR/min requires an Aircraft Limit be generated with the “Max Rate Qc set for at least 200 inHg/min (see “Limits”, page 53, for guidance on Aircraft Limits programming). A suggested Aircraft Limit name would be “EPR” to designate it for use only during EPR tests. The EPR limit would then need to be selected to perform these EPR tests.

(e) Press the ALT / Ps key.

(f) Type in 500 (or 15 if using inHg) and press ENTER Press the EPR key.

(g) Press the EPR key.

(h) Type in 1.8 and press ENTER.

Note: EPR testing can also be performed by specifying the INLET and OUTLET pressures. Using Ps for the INLET pressure and Pt for the OUTLET pressure.

This page intentionally left blank.



DPS500/DPS501 INSTRUCTION MANUAL

CHAPTER 5: RECEIVING, SHIPPING, AND STORAGE

1. RECEIVING

No special unpacking procedures are necessary. It is recommended that the factory-shipping container and packing materials be retained should it become necessary, for any reason, to re-ship the Test Set, such as for the O.E.M. recertification.

It is also recommended that the Test Set undergo a leak check upon receipt (refer to page 77, "DPS500/501 Leak Testing") and its carrying case should be carefully inspected for damage. If the test set has an excessive leak or is damaged, immediately notify the carrier and the manufacturer.

2. SHIPPING

Use standard delicate electronic equipment packaging procedures when packing the Test Set for reshipment.

CAUTION: DO NOT SHIP THE DPS500/501 WITHOUT THE UNIT PACKAGED IN A SUITABLE SHIPPING CONTAINER. BARFIELD INC. WILL NOT BE RESPONSIBLE FOR ANY DAMAGE TO THE DPS500/501 SHIPPED WITHOUT THE PROPER SHIPPING CONTAINER.

3. STORAGE

- A. Place a four-ounce bag of desiccant inside the case.
- B. Close and latch the cover.
- C. Store in a cool dry place.

Note: Should the test set become exposed to moisture or very high humidity, dry it as soon as possible and temporarily store it in a dehumidified area.

This page intentionally left blank.

DPS500/DPS501 INSTRUCTION MANUAL

CHAPTER 6: SERVICING

1. INTRODUCTION

This chapter details the standard serviceability tests available to determine the health of the DPS500/501 Air Data Test Set.

2. STANDARD SERVICEABILITY TEST

A. CONTROLLER TEST

1. The following procedure can be used to check the functions and facilities of the DPS500/501.
2. Connect the DPS500/501 and apply power (refer to procedure starting on page 71).
3. After power has been applied to the DPS500/501 and pump (DPS500 only), check for the power indicator being ON.
4. Ensure the DPS500/501 completes its initialization and Self-Test (page 74) successfully.
5. If no faults are detected, the DPS500/501 display will transition into the standard Leak Measure (user) display as shown below (the solenoid valves will be in the status shown during this function):

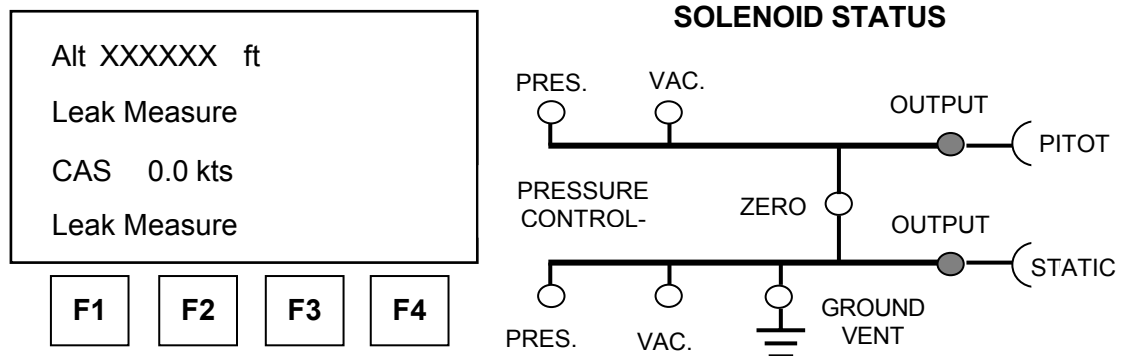

Note: The DPS500/501 always powers up in leak measure mode with the controllers off. In the control mode the pump unit must be switched on and producing the correct pressure and vacuum.

DPS500/DPS501 INSTRUCTION MANUAL

B. PUMP TEST

1. Switch the pump ON.
2. Press SETUP then select F2 (Limits). Repeatedly select NEXT until the display shows "STANDARD".
3. Select SAVE and then press CLEAR / QUIT twice to return to the user display.
4. If the display shows "LEAK MEASURE", select the LEAK MEASURE / CONTROL key to toggle the DPS500/501 into the "Control" mode.
5. Press the SPEED / Qc key to set the test Airspeed.
6. Enter 500 to set the Airspeed at 500 knots and press ENTER.
7. The test set will begin moving towards 500 knots.
8. Press the ROC key to set the Vertical Speed (factory default value is 3000 ft./min).
9. Enter 6000 to set the Vertical Speed value at 6000 ft/min and press ENTER.
10. Press the ALT / Ps key to set the test Altitude.
11. Enter 5000 to set the Altitude value at 5000 feet and press ENTER.
12. The test set will begin moving towards this altitude at the VSI rate entered previously.

Note: When Altitude and Airspeed are changing at the same time, the system automatically adjusts the airspeed rate so that the aim points are reached at the same time. The airspeed rate may be lower then, but will not exceed the entered aim value. This feature is called Automatic Airspeed and can be temporarily disabled by following the procedure for Rate Key Setup (page 46).

13. Check that the test set has attained the set Altitude and / or Airspeed.
14. Upon successful completion of this test procedure, return the DPS500/501 to ground Pressure as follows:
 - (a) If the display shows "LEAK MEASURE", select the LEAK MEASURE / CONTROL key to toggle the DPS500/501 into the "Control" mode.
 - (b) Press the GROUND key.
 - (c) Select F1 "Go To Ground".
 - (d) The unit will automatically return the pressures to ambient pressure and vent system.

DPS500/DPS501 INSTRUCTION MANUAL

15. When Ground (ambient pressure) and zero airspeed have been achieved and all testing completed, disconnect the DPS500/501 from the aircraft or instrument under test. When the test set has vented the system and it is safe to disconnect the aircraft or instrument, the following display will appear:

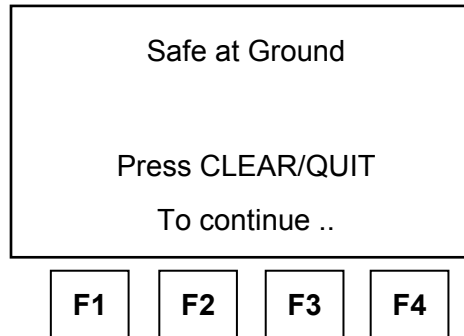

3. DPS500/501 FUNCTIONAL TEST

A. KEY PAD TEST

This Section verifies the Remote Handheld Terminal key-pad operation.

1. Press the MACH / Pt key and check the display changes to show Altitude and Mach measured values.
2. Press every single key, from left to right and from top to bottom and check that the Remote Handheld Terminal beeps on each key press.

Note: The display shows a warning message when the EPR key is pressed. This message should be ignored. DO NOT PRESS the QUIT key to clear the warning message.

B. CONTROLLER STABILITY

This section verifies the control stability.

1. Change the DPS500/501 unit of measure to “mbar”.
 - (a) Press SETUP then select F1 (Units). Repeatedly select NEXT until the display shows “mbar”.
 - (b) Select SAVE and then press CLEAR / QUIT twice to return to the user display. The display should now show Ps and Pt in units of mbar.

DPS500/DPS501 INSTRUCTION MANUAL

2. Change the DPS500/501 limits to “STANDARD”.
 - (a) Press SETUP then select F2 (Limits). Repeatedly select NEXT until the display shows “STANDARD”.
 - (b) Select SAVE and then press CLEAR / QUIT twice to return to the user display.
3. If the display shows “LEAK MEASURE”, select the LEAK MEASURE / CONTROL key to toggle the DPS500/501 into the “Control” mode.
4. Enter a Ps aim of 510 mbar with a rate of change of 200 mbar/min by pressing the following: ALT / Ps, 5, 1, 0, ENTER, ROC / Ps RATE, 2, 0, 0, ENTER.
5. Enter a SPEED / Qc aim of 0 mbar with a rate of change of 200 mbar/min by pressing the following: Qc, 0, ENTER, RATE, 2, 0, 0, ENTER.
6. Press ALT / Ps and wait for the aim values to be achieved.
7. If auto-zero is enabled, wait to an auto-zero to take place. During auto-zero, that valve state changes on the mimic panel and the display shows “ZERO” in place of the airspeed aim value. The time to auto-zero should be less than 1 minute from achieving the aim value.
8. Wait for a minimum of 20 seconds after auto-zero before proceeding.
9. Observe the measure values of Ps and Qc on the display for 1 minute.
10. Check that the displayed value of Ps remains within ± 0.068 mbar.
11. Check that the displayed value of Qc remains within ± 0.068 mbar.

Note: If a further auto-zero takes place, allow the display to stabilize following the auto-zero before proceeding.
12. Upon successful completion of this test procedure, return the DPS500/501 to ground Pressure as follows:
 - (a) If the display shows “LEAK MEASURE”, select the LEAK MEASURE / CONTROL key to toggle the DPS500/501 into the “Control” mode.
 - (b) Press the GROUND key.
 - (c) Select F1 “Go To Ground”.
 - (d) The unit will automatically return the pressures to ambient pressure and vent system.

DPS500/DPS501 INSTRUCTION MANUAL

13. When Ground (ambient pressure) and zero airspeed have been achieved and all testing completed, disconnect the DPS500/501 from the aircraft or instrument under test. When the test set has vented the system and it is safe to disconnect the aircraft or instrument, the following display will appear:

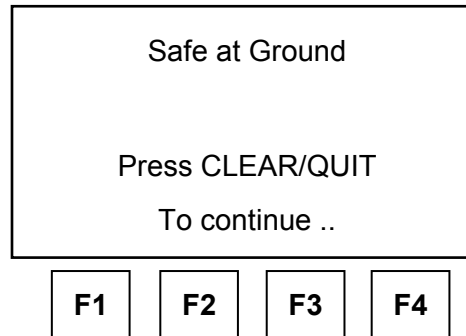

This page intentionally left blank.

DPS500/DPS501 INSTRUCTION MANUAL

CHAPTER 7: TROUBLESHOOTING

1. INTRODUCTION

1. The DPS500/501 contains a built-in self-test and diagnostic system, which continuously monitors the performance of the unit and at power-up carries out a self-test. Warning and error messages are displayed during normal operation if out of range values are entered or if faults occur.
2. This chapter details the error messages and codes that may be displayed when a fault or unauthorized procedure is detected. A fault diagnosis flow chart and table provide the probable cause and procedures to rectify specific symptoms.

2. WARNING MESSAGES (Table 3)

No.	Message	Probable Cause	Action
2	INVALID USER INPUT	The numeric value entered was outside the allowed range.	Re-enter value within allowed range.
3	OPERATE CAL ENABLE ON STATUS PANEL	Calibration started before removing calibration enable plate on the front panel.	Return to repair shop.
4	ONLY VALID IN CONTROL MODE	Selection not allowed in measure mode.	Select controller on.
210	Ps SOFT START TIME-OUT	The Ps controller has failed to go into control mode.	Select CONTROL again. If fails again, return to repair shop.
212	Ps PRESSURE FAIL	The Ps controller has detected loss of supply pressure and automatically switched all channels to measure mode. This can occur at very high rates of pressure change in large volume systems if the pump cannot produce enough pressure.	Restore pressure supply BEFORE going to control mode again. Increase capability of pump.
213	Ps VACUUM FAIL	The Ps controller has detected loss of supply pressure and automatically switched all channels to measure mode. This can occur at very high rates of pressure change in large volume systems if the pump cannot produce enough vacuum.	Restore vacuum supply BEFORE going to control mode again. Increase capability of pump.
220	Pt SOFT START TIMEOUT	The Pt controller has failed to go into control mode.	Select CONTROL again. If fails again, return to repair shop.
222	Pt PRESSURE FAIL	The Pt controller has detected loss of supply pressure and switched all channels to measure mode. This can occur at very high rates of pressure change in large volume systems if the pump cannot produce enough pressure.	Restore pressure supply BEFORE going to control mode again. Increase capability of pump.

DPS500/DPS501 INSTRUCTION MANUAL

2. WARNING MESSAGES (Table 3) (Continuation)

No.	Message	Probable Cause	Action
223	Pt VACUUM FAIL	The Pt controller has detected loss of supply pressure and automatically switched all channels to measure mode. This can occur at very high rates of pressure change in large volume systems if the pump cannot produce enough vacuum.	Restore vacuum supply BEFORE going to control mode again. Increase capability of pump.
301	LEAK RATE TOO HIGH REGAINING CONTROL	Control mode automatically regained for aircraft safety as leak rates too high (see Auto Leak function, page 43).	Correct leak and re-test. May inadvertently occur if LEAK MEASURE / CONTROL key is pressed (toggle unit into Leak Measure mode) during active climb or descend.
302	OUTSIDE LIMITS REGAINING CONTROL	Control mode automatically regained for aircraft safety as the measured values have drifted outside of the operation limits due to leaks (see Auto Limit function, page 44).	Correct leak and re-test. If leak testing Ps, ensure that nominal Qc pressure is applied (e.g. 200 knots) is applied to avoid negative airspeed.
303	ZERO OFFSET TOO LARGE	The zero offset measured during auto-zero was outside limits.	Return to shop for calibration.
304	INITIALIZING BLANK SYSTEM EEPROMS	This should only occur if new EEPROM's have been fitted.	If message occurs during normal operation, refer to manufacturer.
305	OUTSIDE LIMITS GO TO GROUND	Measured pressure is outside new limits selected or power-up limits.	Control pressures to within limits.
306	SWITCH PUMPS ON	Cannot select control mode with the pump off.	Switch pump ON.
307	COMMUNICATIONS RING FAULT – PACKET IS CORRUPT	Internal error	Reset the system. If it fails again, return to repair shop.
	CAN NOT EDIT CURRENT LIMITS. PRESS CLEAR/QUIT TO CONTINUE.	When an aircraft limit is currently selected, it cannot be edited through Configuration.	Use SETUP to select another limit value and repeat the previous operation.
	ACTION NOT VALID IN CONTROL MODE. PRESS CLEAR / QUIT TO CONTINUE.	Selection not allowed in control mode	Place DPS500/501 in LEAK MEASURE mode and repeat the previous operation.
	ACTION NOT VALID. PRESS CLEAR / QUIT TO CONTINUE.	EPR operation requires the DPS500/501 to be in a unit of measure other than Aeronautical (Altitude and Airspeed).	Use SETUP to change the unit of measure to inHg, mbar, etc. then press the EPR key.
		The DPS500 must be in CONTROL mode before operation of the Go to Ground function.	Place DPS500/501 in CONTROL mode and repeat the previous operation

DPS500/DPS501 INSTRUCTION MANUAL

3. ERROR MESSAGES

A. In the event of a malfunction, the built-in self test and diagnostic system displays an error message indicating the error and an error code. A DPS500/501 displaying this type of malfunction should be returned to the repair depot. The malfunctions are as follows:

513	"PSU ERROR"
514	"COMMS RING ERROR"
515	"PSU NO LONGER READY"
516	"UNKNOWN CONTROLLER ERROR"
517	"RING TIME OUT"
518	"PEEL IRQ LOST"
601	"INTERNAL RAM ERROR"
602	"EEPROM CORRUPTION"
603	"ERROR WRITING TO EEPROM"
603	"SYSTEM EEPROMS FAULTY OR NOT FITTED"
701	"PS SELF-TEST ERROR"
702	"PT SELF-TEST ERROR"
703	"PS SELF-TEST TIME OUT ERROR"
704	"PT SELF-TEST TIME OUT ERROR"
710	"PS CONTROLLER ERROR"
711	"PS CONTROLLER ERROR"
712	"PS CONTROLLER ERROR"
713	"PS CONTROLLER ERROR"
714	"PS CONTROLLER ERROR"
717	"PS CONTROLLER ERROR"
720	"PT CONTROLLER ERROR"
721	"PT CONTROLLER ERROR"
722	"PT CONTROLLER ERROR"
723	"PT CONTROLLER ERROR"
724	"PT CONTROLLER ERROR"
727	"PT CONTROLLER ERROR"
801	"IEEE488 DRIVER FAILED TO OPEN"
802	"IEEE488 DRIVER FAILED TO RESET"
900	"INTERNAL SOFTWARE"
999	"INTERNAL ERROR"

DPS500/DPS501 INSTRUCTION MANUAL

- B. Some errors display extra information using a four digit hexadecimal code. This should always be recorded with the error number to provide information for the repair depot.

Note: The HHHH is a hexadecimal code representing the error.

Note: An error 701:0100 or 702:0100 may indicate an internal overpressure if the DPS500/501 has previously been overpressured.

4. SELF-TEST ERRORS

- A. At power-up, the DPS500 / 501 indicates if there is a fault on one of the controllers by displaying:

701:HHH PS SELF-TEST ERROR
or 701:HHH PS SELF-TEST ERROR

- B. Controller Run Time Errors

- (1) If a controller fault occurs during normal operation, an error will be displayed.
- (2) Controller errors have additional information contained in one byte. Refer to the service manual.

5. FAULT DIAGNOSIS

- A. If the display shows a warning or error message, refer to the above sections.
- B. If a fault occurs, refer to the fault location chart, Figure 20, page 6 and Table 4, page 107 for possible fault causes and recommended action.

DPS500/DPS501 INSTRUCTION MANUAL

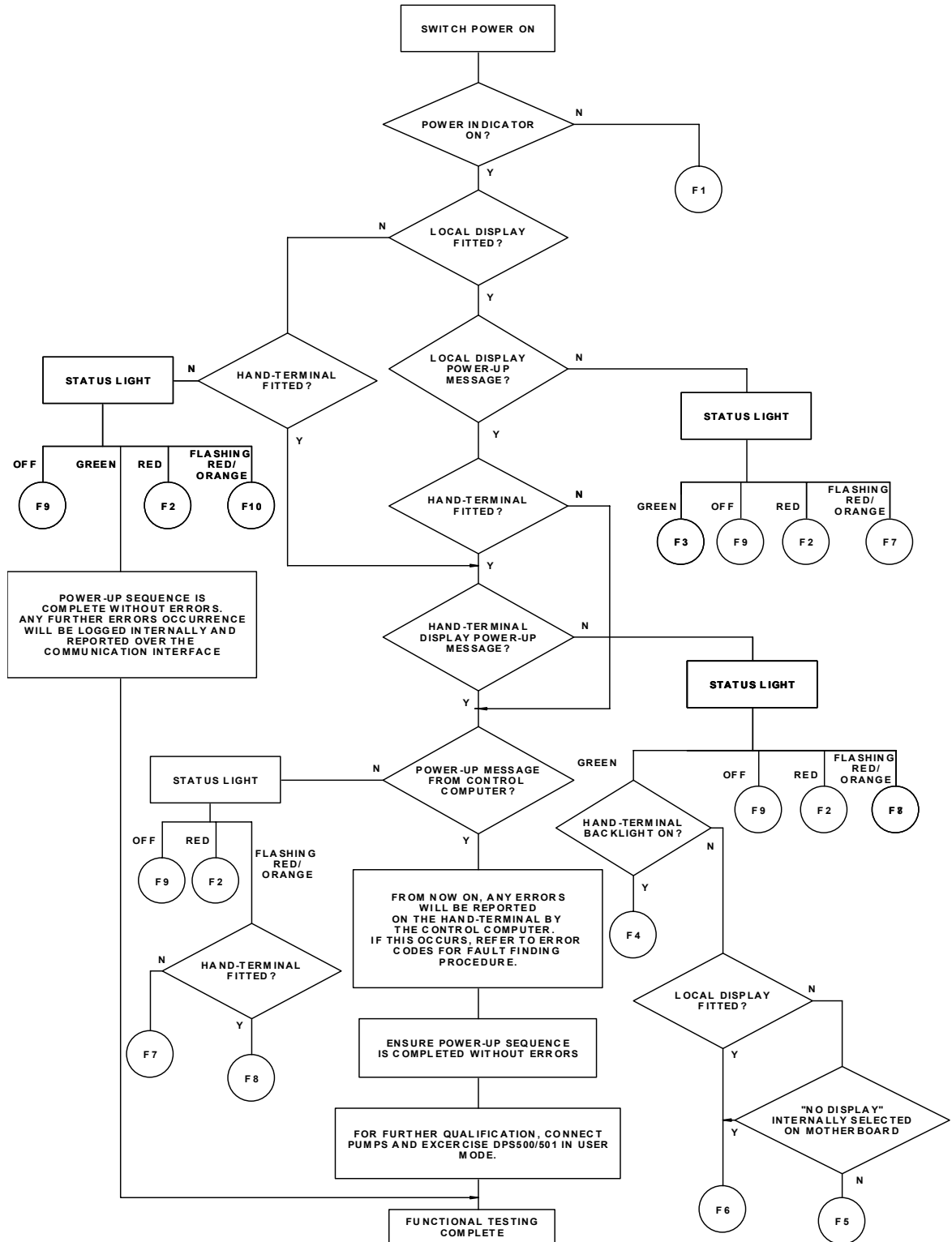

Figure 20 DPS500/501 Fault Finding Chart

DPS500/DPS501 INSTRUCTION MANUAL

Table 4 DPS500/501 Fault Finding Table

Fault	Symptom	Probable cause	Action
F1	Power-on indicator does not light.	Faulty power supply outlet. Blown fuse in power supply. Blown fuse in DPS500/501 Faulty power supply cable	Check power supply. Check / replace fuse. Replace cable and re-test.
F2	Display power-up message appears and status light remains red	Internal supervisor fault.	Record fault and send to depot for repair.
F3	No local display power-up message, status light green.	Display fault.	Use an available hand-terminal. Record fault and send hand-terminal to depot for repair.
F4	No Remote Handheld Terminal display, status light green. Remote Handheld Terminal back-light on.	Remote Handheld Terminal fault. (cable ok)	Replace Remote Handheld Terminal. Record fault and send Remote Handheld Terminal to depot for repair.
F5	No Remote Handheld Terminal display, status light green. Remote Handheld Terminal back-light not on.	No local display connected: Remote Handheld Terminal fault (cable ok).	Replace Remote Handheld Terminal. Record fault and send Remote Handheld Terminal to depot for repair.
F6		Local display fitted or no local display and "No display" internally selected on motherboard. Hand-terminal cable fault.	Replace cable. Replace Remote Handheld Terminal. Remote Handheld Terminal or hand-terminal cable fault. Record fault and send hand-terminal / cable to depot for repair.
F7	No hand terminal or local display. Status light flashing red / orange.	No hand-terminal or local display detected.	Local display only: internal fault. Record fault and send DPS500/501 to depot for repair.
F8			Hand-terminal fitted: Replace cable. Replace hand-terminal.
F9	Status light off.	Internal PSU fault.	Record fault and send DPS500/501 to depot for repair.
F10	No hand-Terminal connected or local display fitted. Status light flashing red / orange.	For normal operation, there must be either a local display or a hand-terminal fitted at power-up. If it is required to operate the DPS500/501 as a "black box" from a communications interface without a hand terminal, the internal switch on the mother board must be set to "NO DISPLAY".	Fit hand-terminal or check mother board switch.
F11	Error 70X:0100 displayed and overpressure has been applied to the DPS500/501.	Internal overpressure.	Vent system, refer to page 110.

DPS500/DPS501 INSTRUCTION MANUAL

6. VENTING AFTER OVERPRESSURE

To calibrate or test the DPS500/501, an external pressure source is connected to the Ps and / or Pt output connectors. If, during calibration or test procedures, an overpressure situation occurs, the output valves close to protect the system. After the valves close pressure may be trapped in the internal system; the display may show on the next power-up error 701:0100 or 702:0100. To vent this pressure proceed as follows:

- A. Remove the source of pressure and vent Ps and Pt to atmosphere (caps off).
- B. Re-power the DPS500/501. During the power-up screen:

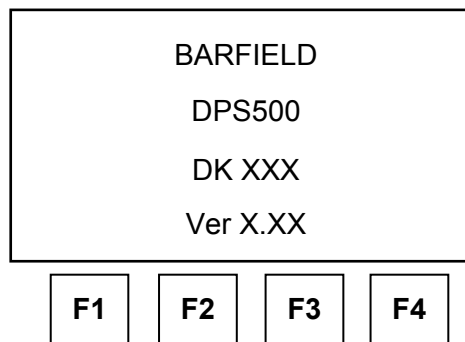

CAUTION: ONLY SELECT ITEMS IN THE FOLLOWING MENU, INCORRECT SELECTIONS CAN CAUSE CHANGES TO THE SAFETY LIMITS AND CALIBRATION OF THE SYSTEM.

- C. Press F1 and F4 simultaneously. The DPS500/501 enters the maintenance mode with the following screen displays.

Note: The system may prompt for a PIN number. This is not the CONFIG PIN but the Calibration PIN number. If this Calibration PIN is enabled and not entered, the system will not execute the following procedures.

DPS500/DPS501 INSTRUCTION MANUAL

1. The system enters the maintenance mode with the following screen display:

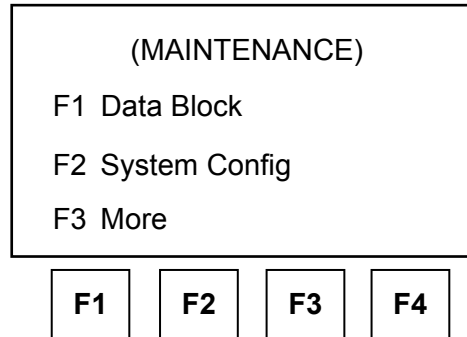

2. Select F3 (More). The display shows:

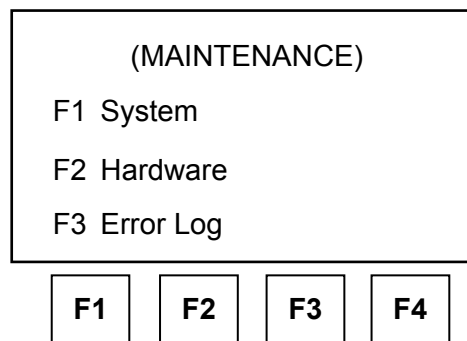

3. Select F1 (System). The display shows:

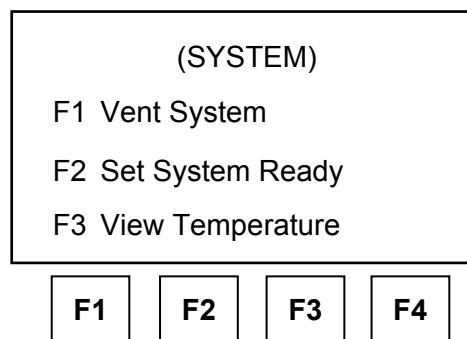

4. Select F1 (Vent System). When complete, press QUIT three times to reset the system.

This page intentionally left blank.